

RM-PC500

Advanced Step Controllers

Description

PC500 Model devices are 48 96 mm industrial instruments designed for measuring and controlling (On/Off or PID) various process variables such as temperature, pressure, speed, level, humidity, current, voltage, and resistance. They are fully modular, with each module independently configurable.



General Features

- Display: 3 sets of 4-digit numeric displays and LCD indicator.
- Indicators: LED indicators for relays.
- Keys: 5 capacitive touch keys.
- Sensor Input: 1 Universal sensor input (TC, RT, mA, mV, V).
- Additional Inputs: 1 Potentiometer input and 1 Auxiliary analog input (0/4-20mA). Digital Inputs: 3 Digital inputs (15V).
- Outputs: 2 Analog outputs (0/4-20mA, 0/2-10V) and 4 Relay or Logic outputs (24V). Transmitter Power: 1 Transmitter supply output (24VDC).
- Communication: 1 RS485 communication unit (MODBUS RTU).
- Power Supply: 100-240V AC/DC Universal or 24V AC/DC.

Functional Features

- Step Control: 100 Programs with a total of 800 steps.
- Control Types: ON/OFF, P, PI, PD, PID control.
- Valve Control: Proportional valve control with or without position feedback.
- Tuning: Auto-Tuning and Self-Tune features.
- Special Functions: PID Heating/Cooling, Bumpless Transfer, Ramp Function, and Retransmission.
- Safety: Sensor failure detection and 7 different power failure behavior modes.
- Cycle Time: 100ms sampling and control cycle.

Device Dimensions

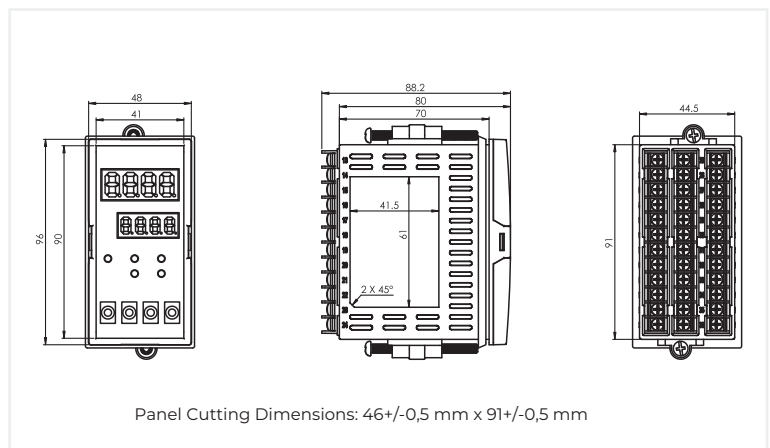

Applications

Used in Food, Plastic, Iron & Steel, Chemical, Metallurgy, Cement, Ceramic, Petro-Chemical, Refineries, Glass, and other industrial sectors

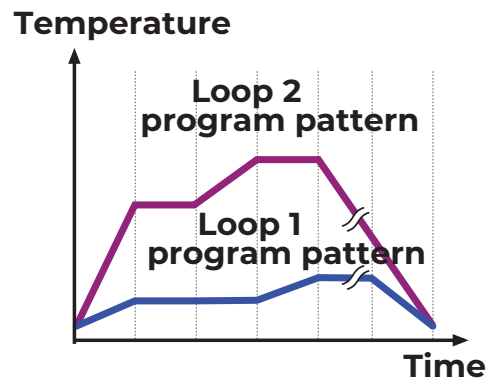
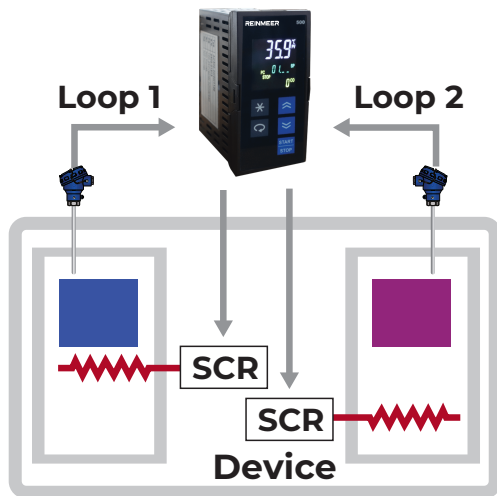

Program pattern operation

Technical Specifications

Accuracy	+/- 0.2%
Sampling Time	100 ms
Memory	100 years, 100,000 renewals.
Operating Temperature	-10...+55°C
Protection Class	IP54 (Front Panel), IP20 (Rear Panel).
Relay Contact Life	1,000,000 operations at 250V 10A resistive load; 10,000,000 operations no-load.
Dimensions	48 x 96 x 78.2 mm
Panel Cut-out	45.5 x 92 mm (+/- 0.5 mm)
Weight	430 gr

Electrical Wiring Diagram

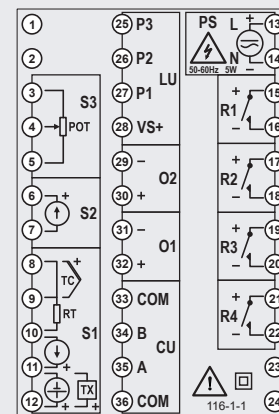

Module	Description
S1	Universal sensor input module (The sensor used for process value measurement is connected to the terminals with the appropriate symbol in this module).
S2	0/4-20mA auxiliary analog input module (The function of this module can be selected via the device).
S3	100-1500 Ω Potentiometer input or
LU	Logic input module
CU	RS485 communication module. (The content of this module is determined by the product code, and functions can be selected via the device).
O1,O2	Analog output modules (The content of this module is determined by the product code, and functions can be selected via the device).
R1,R2,R3,R4	Relay output modules. (The content of this module is determined by the product code, and the function is selected via the device).
PS	Power supply input. (The supply voltage is determined by the product code).