



## RM-MOC SERIES COMPACT TYPE NO STRAIGHT PIPE REQUIRED ELECTROMAGNETIC FLOWMETER

---

PULSE | FREQUENCY | RS485 MODBUS | 4...20MA  
(OPTIONAL HART)

RELIABLE MEASUREMENTS FOR  
THE RIGHT DECISIONS

# REINMEER

## RM-MOC SERIES COMPACT TYPE NO STRAIGHT PIPE REQUIRED ELECTROMAGNETIC FLOWMETER

TOUCHSCREEN  
CAPACITIVE KEY  
PANEL

CORROSION-  
RESISTANT  
EXTERIOR  
COATING  
RESISTANT TO  
CORROSION

TEFLON / EBONITE /  
EPDM  
INTERIOR LINING  
OPTIONS

St37 STEEL  
MOLD BODY

PULSE | FREQUENCY | RS485 MODBUS | 4...20MA  
(OPTIONAL HART)

[www.reinmeer.com](http://www.reinmeer.com)

## WORKING PRINCIPLE

Electromagnetic flow measurement: a flow measurement method based on the principle of electromagnetic fields.

The physical foundations of this principle are based on the work of English physicist Michael FARADAY, who discovered in 1831 that an electric current could be generated using a magnetic field. In 1941, Swiss scientist Bonaventura Thurlemann applied this knowledge to conductive liquids flowing through pipes and produced the world's first electromagnetic flow meter.

The RM-MOC Series Compact Type Series electromagnetic flowmeter contains two coils. These coils create a continuous magnetic field across the cross-sectional area of the measuring tube with the help of metal blocks placed on them. Two electrodes that detect voltage are placed perpendicular to each other inside the measuring tube. The insulating material coating the inner surface prevents short circuits between the conductive liquid and the metal measuring tube. When there is no flow, no electrical voltage occurs between the two electrodes.

Negatively and positively charged ions are present in equal amounts in the conductive liquid. When flow begins, the magnetic field applies a force to the charged ion particles in the liquid. As a result, the negatively and positively charged ions in the liquid separate and move towards opposite sides of the measuring tube. This results in an electrical voltage detected by the electrodes.

This voltage is directly proportional to the flow velocity in the line. The instantaneous flow rate can be calculated using the known volume of the measuring tube and the velocity information.

As the flow velocity increases, the separation of charged particles also increases, and the voltage between the electrodes will increase. The measuring electrodes may occasionally detect magnetic noise present in the environment. This noise signal must be clearly distinguished from the actual measurement signal. To achieve this, the magnetic field must be generated using pulsed direct current. By continuously changing the positions of the charged ions between the electrodes using pulsed direct current, the effect of magnetic noise is eliminated, enabling accurate and stable flow measurement.

Flow information is calculated using the following simplified formula based on the electromagnetic measurement principle.

- $U_e = B \cdot L \cdot v$
- $B$  = magnetic induction (magnetic field)
- $L$  = distance between electrodes
- $v$  = flow rate
- $Q$  = volume flow
- $A$  = pipe cross-section

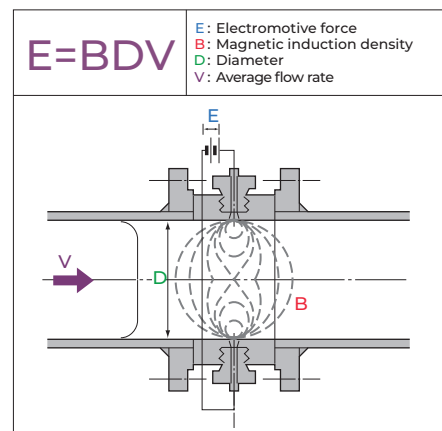
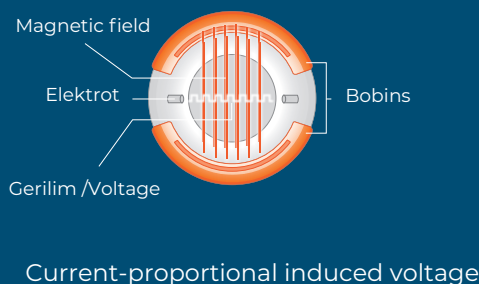
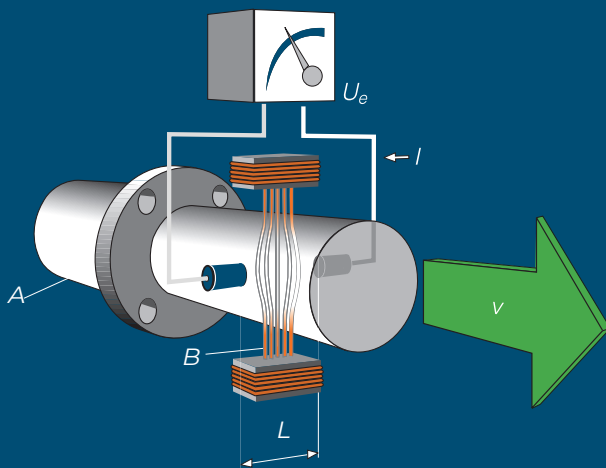

## AREAS OF APPLICATION

RM-MOC Series Compact Electromagnetic Flow Meters can be easily used for volumetric flow measurement of water and wastewater applications, as well as any water-based or conductive liquids.

Furthermore, with a wide range of internal coating and electrode material options, they provide reliable solutions for volumetric flow measurement of acids, alkalis, and corrosive chemicals used in industry. Furthermore, electromagnetic flowmeters are widely used in the measurement of the volumetric flow of special products such as ore, sludge, slurry, paste, and dough found in the mining and paper industries.

The RM-MOC Series Compact Type electromagnetic flowmeter has no moving parts, so it does not cause changes in process pressure and has very low maintenance costs. Furthermore, this feature allows for “full passage” and a very wide measurement range.

Chemical Industry



Agriculture Industry



Food Industry



Water and Wastewater



Paper Industry



Mining



**TECHNICAL DRAWING**

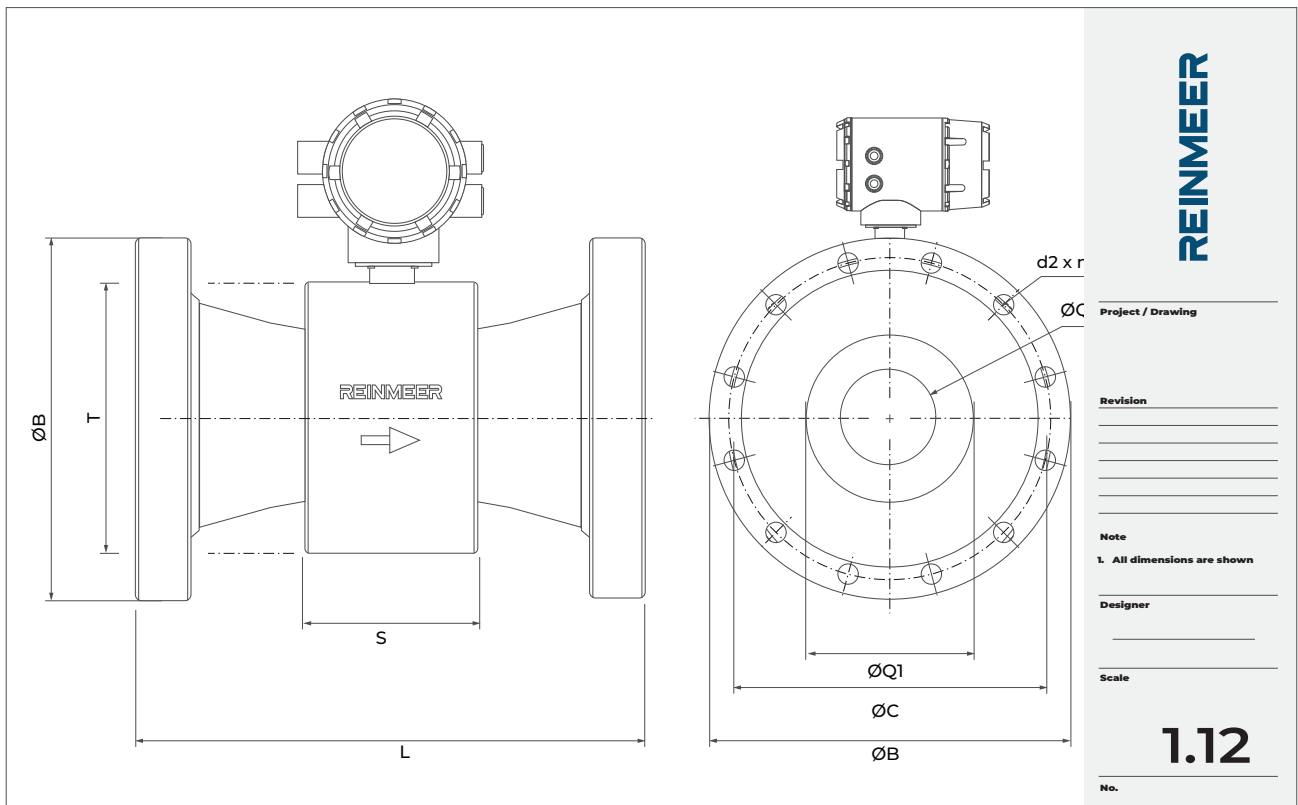
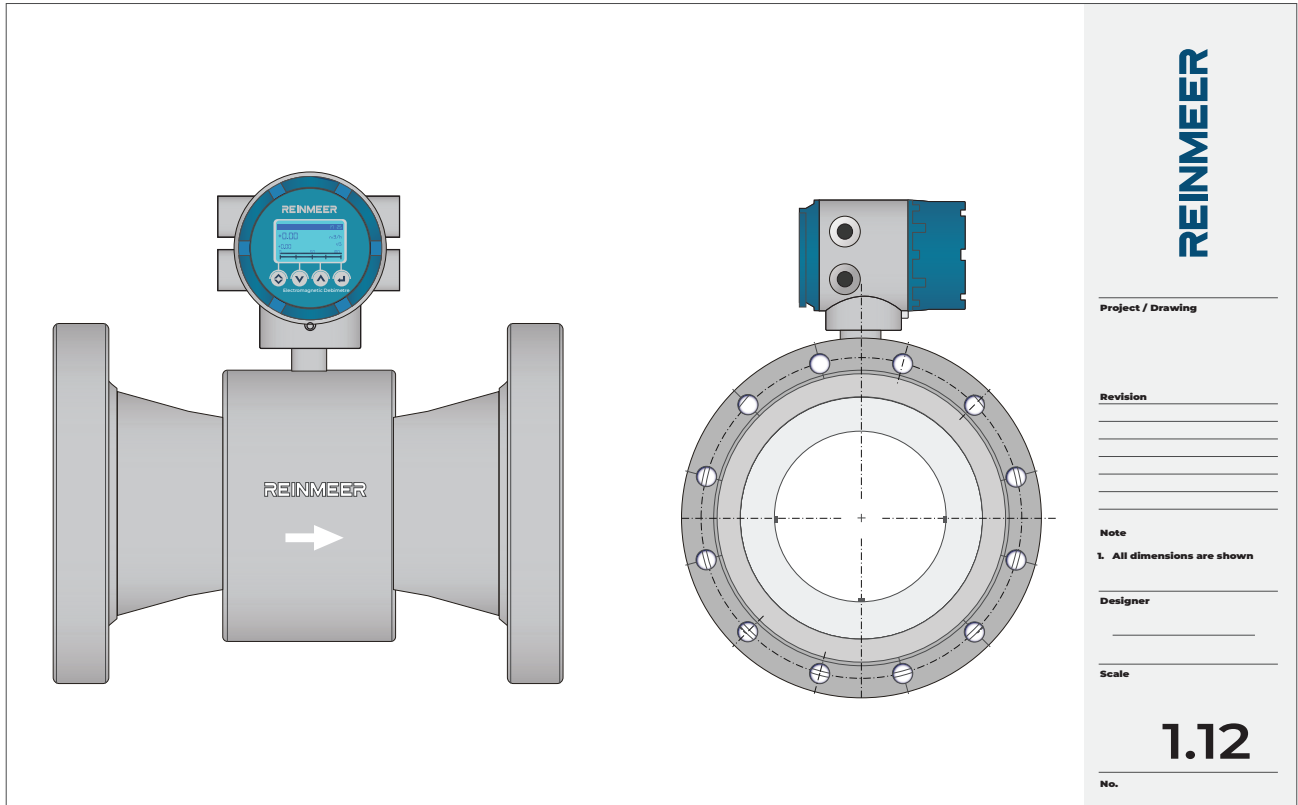

## TEKNİK ÖZELLİKLER

### Standard Body

<b>Body Structure</b>	St37 Steel Mold Body (Standard)	Stainless Steel 1.4301 (Optional)	
<b>Measuring Tube Material</b>	316 Stainless Steel		
<b>Nominal Diameters</b>	DN50 - DN3000 DIN EN 1092-1 From B ½" ... 12" ASME 16,5 RF		
<b>Flange Material</b>	Alloy Steel ST 37-2 (Standard)	Stainless Steel 1.4301 (Optional)	
<b>Nominal Pressures</b>	DN50-DN80	PN 40 (standard)	PN16, PN25, PN10 (Optional)
	DN100-DN150	PN 16 (standard)	PN10, PN25, PN40 (Optional)
	DN200-DN3000	PN 10 (standard)	PN16, PN25, PN40,PN6 (Optional)
<b>Process Temperature</b>	-10 ... +80 °C	Ebonit	
	-10 ... +70 °C	EPDM (Soft Rubber)	
	-20 ... +150 °C	PTFE (TEFLON)	
	-20 ... +120 °C	Black PTFE	
		Teflon coating	
<b>Interior Lining Material</b>	Ebonite, EPDM, PTFE, Black PTFE, Ceramic		
<b>Meas. Electrode Material</b>	316 Stainless Steel, Hastelloy C22, Tantalum, Titanium, Platinum Rhodium		
<b>Grounding Electrode Material</b>	316 Stainless Steel, Hastelloy C22, Tantalum, Titanium, Platinum Rhodium		
<b>Grounding Ring</b>	A plastic grounding ring should be preferred.		
<b>Ambient Temperature</b>	-20 to +60 °C (Process temperature dependent)		
<b>Protection Class</b>	IP67 (Compact Model) / IP68 (Separate Model)		

### Square Transmitter

<b>Body Material</b>	Cast Aluminum		
<b>Installation Method</b>	Compact		
<b>Supply Voltage</b>	220 VAC / 24 VDC. (one selectable)	battery (optional)	
<b>Local Screen</b>	Backlit LCD Display 64x128		
<b>Display Languages</b>	English, German, Spanish (2 languages can be selected)		
<b>Output Signals</b>	Pulse, Frequency, RS485 MODBUS, 4...20mA, (Optional HART)		
<b>Digital Input</b>	Start/stop flow reading / Clear errors / Reset total flow		
<b>Ambient Temperature</b>	-20 ... +60 °C (Depending on process temperature)		
<b>Alarms</b>	1x passive pulse (12-36VDC, 100 mA, 1,5 kΩ) (Empty Tube, Sensor Error, Overlimit options can be selected)		
<b>Display</b>	4-button, 3-line, 30-digit LCD		
<b>Protection Class</b>	IP67		

**Position of Shrink-Fit Flange Gaskets**

**A**  
Grounding Ring

**B**  
Gasket

Flow

The use of a grounding ring is mandatory in plastic lines and lines with internal insulation.

**REINMEER**

---

Project / Drawing

---

Revision

---



---



---



---

Note

1. All dimensions are shown

---

Designer

---

Scale

---

1.12

---

No.

**REINMEER**

---

Project / Drawing

---

Revision

---



---



---



---

Note

1. All dimensions are shown

---

Designer

---

Scale

---

1.12

---

No.

In non-grounded pipe lines, the grounding ring must be mounted between the sensor flange and the pipe. Material: SS 316 or Hastelloy C  
Thickness: 2 mm for SS 316 / 1 mm for Hastelloy C

Grounding Ring

Non-conductive pipeline

The use of a grounding ring is mandatory in plastic lines and lines with internal insulation.

**REINMEER**

---

Project / Drawing

---

Revision

---



---



---



---

Note

1. All dimensions are shown

---

Designer

---

Scale

---

1.12

---

No.

**REINMEER**

---

Project / Drawing

---

Revision

---



---



---



---

Note

1. All dimensions are shown

---

Designer

---

Scale

---

1.12

---

No.

Grounding a Flow Meter in a Non-Conductive Pipe.

## Flowmeter Connection Dimensions

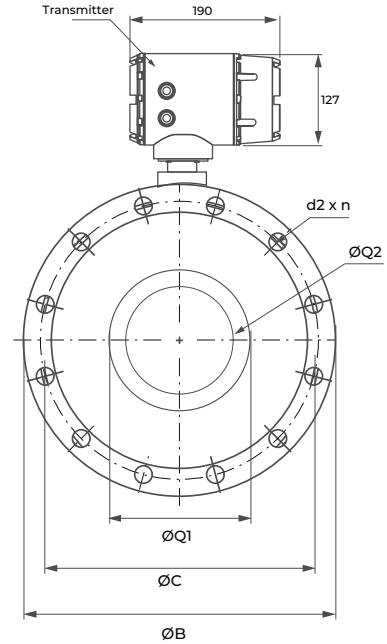
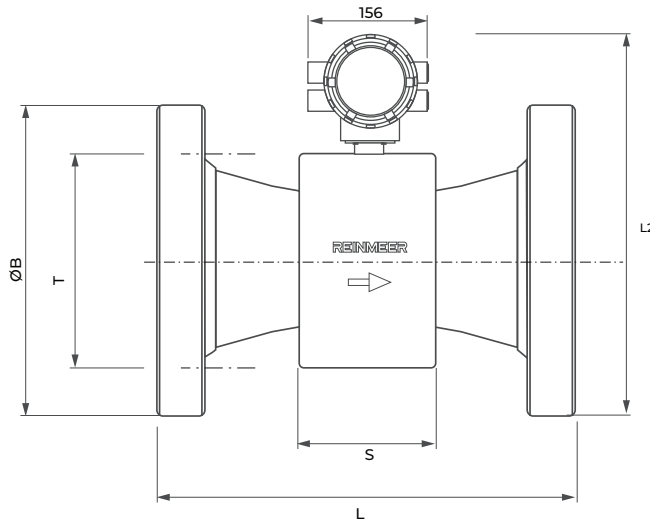

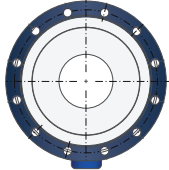
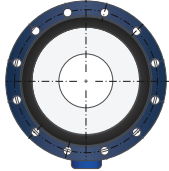
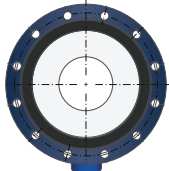
Material Type	DN (mm) Q1	DN (mm) Q2	Pressure Class	Flange								
				L1	L2	B	C	S	T	D	Number of holes (d)	Bolt Diameter
 Teflon	50	25	40 Bar	200	340	165	125	110	140	18	4	M16
	80	40		200	360	200	160	95	160	18	8	M16
	100	50	16 Bar	250	410	220	180	155	210	18	8	M16
	125	100		250	410	250	210	115	210	18	8	M16
	150	125		300	410	285	240	130	270	22	8	M16
	200	150		350	470	340	295	145	320	22	8	M20
 Ebonit	250	200	10 Bar	400	520	395	350	175	370	22	12	M20
	300	250		500	570	445	400	230	450	22	12	M20
	400	300		600	650	565	515	235	530	26	16	M24
	500	350		600	670	670	620	245	630	26	20	M24
	600	400		600	730	780	725	320	740	30	20	M27
	700	500		700	830	895	840	370	850	30	24	M27
	800	600		800	940	1015	950	400	970	33	24	M30
	900	700		900	1050	1115	1050	400	1070	33	28	M30
 Kauçuk	1000	800	6 Bar	1000	1170	1230	1160	500	1150	36	28	M33
	1200	900		1200	1270	1455	1380	600	1390	39	32	M36
	1400	1000		1400	1350	1675	1590	700	1590	42	36	M39
	1600	1200		1600	1590	1915	1820	800	1760	48	40	M45
	1800	1400		1800	1790	2115	2020	800	1970	48	44	M45
	2000	1600		2000	1960	2325	2230	1000	2160	48	48	M45

### FLOW RATE / DIAMETER / SPEED TABLE

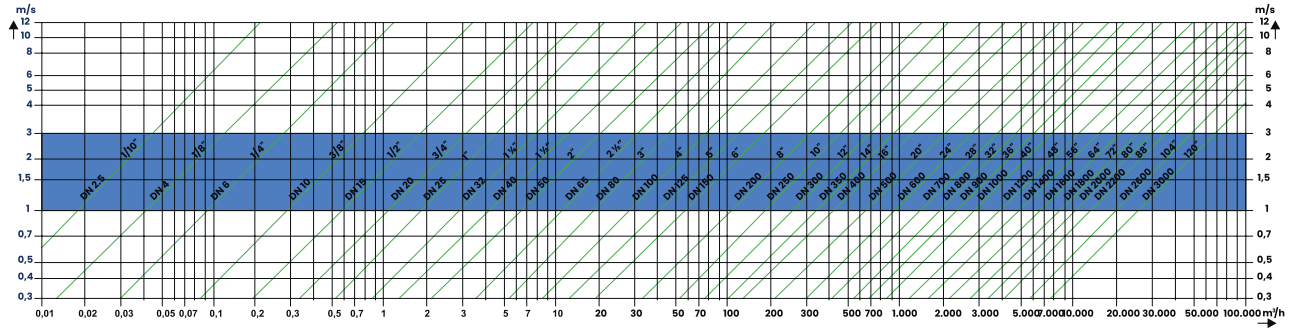

- 1- The appropriate product diameters can be selected based on flow rate information.
- 2- The appropriate product diameters can be selected based on velocity information.
- 3- The flow measurement range can be selected based on diameter information.

### DIAMETER / FLOW RATES

DN (mm)	DIAMETER	MIN. FLOW RATE (m³/h)	MAX. FLOW RATE (m³/h)	PRECISE MEASUREMENT RANGE (m³/h)
DN 50	2"	2,2	85	6,8-22,0
DN 65	2 1/2"	3,6	150	13-32
DN 80	3"	5,5	210	18-48
DN 100	4"	8,5	320	28-48
DN 125	5"	13	550	42-130
DN 150	6"	18	750	58-180
DN 200	8"	32	1500	120-320
DN 250	10"	52	2020	180-480
DN 300	12"	78	3010	250-700
DN 350	14"	100	4010	350-900
DN 400	16"	140	5050	440-1400
DN 500	20"	220	7880	650-2000
DN 600	24"	300	10030	950-2800
DN 700	28"	420	18000	1500-3500
DN 800	32"	550	22000	1800-4800
DN 900	36"	700	28000	2400-6000
DN 1000	40"	850	32000	2800-8000
DN 1200	48"	1200	48000	3800-14000
DN 1400	56"	1600	58000	5000-16000
DN 1600	64"	2200	88000	6500-22000

- 4- The most stable range for measurement is considered to be 1-3 m/s.

**ANSI 15 - 300 Flange Dimensions**

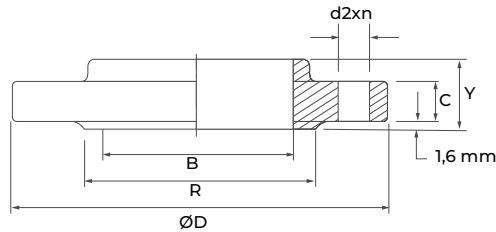
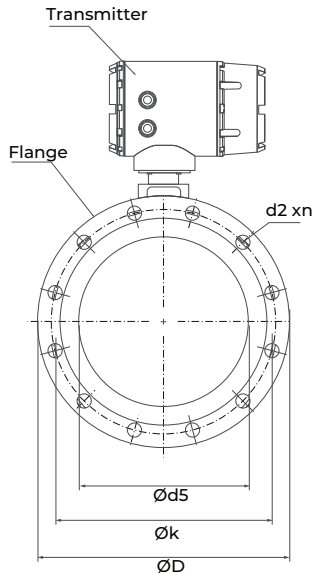

**SLIP-ON FLANGE 150 LB  
SLIP-ON FLANGE CLASS 150  
(ASME B 16.5 + MSS - SP 44 - 1996)  
BS 3293**

PIPE		D	C min	R	HOLES			B min	X	Y	WEIGHT kg
DN	NPS				n	K	d <sub>2</sub>				
15	1/2"	89	11,2	34,9	4	60,3	15,8	22,4	30	16	0,8
20	3/4"	99	12,7	42,9	4	69,8	15,8	27,7	38	16	0,9
25	1"	108	14,3	50,8	4	79,4	15,8	34,5	49	17	1
32	1 1/4"	117	15,7	63,5	4	88,9	15,8	43,2	59	21	1,3
40	1 1/2"	127	17,5	73	4	98,4	15,8	49,5	65	22	1,5
50	2"	152	19,1	92,1	4	120,6	19	62	78	25	2,3
65	2 1/2"	178	22,3	104,8	4	139,7	19	74,7	90	29	3,7
80	3"	190	23,9	127	4	152,4	19	90,7	108	30	4,2
100	4"	229	23,9	157,2	8	190,5	19	116,1	135	33	5,9
125	5"	254	23,9	185,7	8	215,9	22,2	143,8	164	37	7
150	6"	279	25,4	215,9	8	241,3	22,2	170,7	192	40	8,5
200	8"	343	28,5	269,9	8	298,4	22,2	221,5	246	44	13,5
250	10"	406	30,2	323,8	12	362	25,4	276,4	305	49	19,5
300	12"	483	31,8	381	12	431,8	25,4	327,2	365	56	29

**SLIP-ON FLANGE 300 LB  
SLIP-ON FLANGE CLASS 300  
(ASME B 16.5 + MSS - SP 44 - 1996)  
BS 3293**

PIPE		D	C min	R	HOLES			B min	X	Y	WEIGHT kg
DN	NPS				n	K	d <sub>2</sub>				
15	1/2"	95	14,2	34,9	4	66,7	15,8	22,4	38	22	1,2
20	3/4"	117	15,7	42,9	4	82,6	19	27,7	48	25	1,3
25	1"	124	17,5	50,8	4	88,9	19	34,5	54	27	1,4
32	1 1/4"	133	19	63,5	4	98,4	19	43,2	64	27	1,8
40	1 1/2"	156	20,6	73	4	114,3	22,2	49,5	70	30	2,5
50	2"	165	22,4	92,1	8	127	19	62	84	33	3
65	2 1/2"	190	25,4	104,8	8	149,2	22,2	74,7	100	38	4,5
80	3"	210	28,4	127	8	168,3	22,2	90,7	117	43	6
100	4"	254	31,8	157,2	8	200	22,2	116,1	146	48	10,1
125	5"	279	35	185,7	8	235	22,2	143,8	178	51	12,5
150	6"	318	36,6	215,9	12	269,9	22,2	170,7	206	52	17,5
200	8"	381	41,1	269,9	12	330,2	25,4	221,5	260	62	26
250	10"	444	47,8	323,8	16	387,4	28,5	276,4	320	66	28
300	12"	521	38,1	381	16	450,8	31,8	327,2	375	73	52

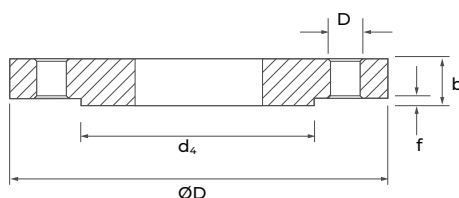
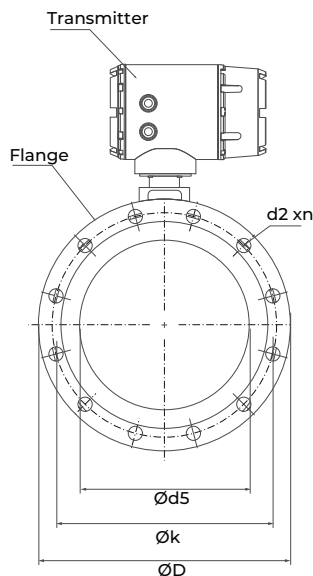

Pn 6 Steel Flat Flange  
TS-EN 1092-1/  
TYPE 01 / DIN 2576

PIPE	FLANGE					FOREHEAD PROTRUSION		HOLES			WEIGHT	
	DN	d <sub>s</sub>	D	b		k	d <sub>4</sub>	f	n	screw	d <sub>2</sub>	EN 1092 - 1 kg/ad - kg/pcs
			EN 1092-1	DIN2501								
15	22	80	12	12	55	40	2	4	M10	11	0,35	0,35
20	27,5	90	14	14	65	50	2	4	M10	11	0,53	0,53
25	34,5	100	14	14	75	60	2	4	M10	11	0,65	0,65
32	43,5	120	16	14	90	70	2	4	M12	14	1,05	0,91
40	49,5	130	16	14	100	80	3	4	M12	14	1,20	1,00
50	61,5	140	16	14	110	90	3	4	M12	14	1,30	1,10
65	77,5	160	16	14	130	110	3	4	M12	14	1,60	1,40
80	90,5	190	18	16	150	128	3	4	M16	18	2,60	2,30
100	116	210	18	16	170	148	3	4	M16	18	2,90	2,50
125	141,5	240	20	18	200	178	3	8	M16	18	3,90	3,50
150	170,5	265	20	18	225	202	3	8	M16	18	4,30	3,80
200	221,5	320	22	20	280	258	3	8	M16	18	6,30	5,60
250	276,5	375	24	22	335	312	3	12	M16	18	8,20	7,50
300	327,5	440	24	22	395	365	4	12	M20	22	10,60	9,60
350	359,5	490	26	22	445	415	4	12	M20	22	15,30	12,70
400	411	540	28	22	495	465	4	16	M20	22	18,20	13,90
450	462	595	30	22	550	520	4	16	M20	22	22,70	16,10
500	513,5	645	30	24	600	570	4	20	M20	22	24,40	19,10
600	616,5	755	32	24	705	670	5	20	M24	26	31,50	22,80
700	718	860	40	24	810	775	5	24	M24	26	47,50	27,80
800	819	975	44	24	920	880	5	24	M27	30	65,30	33,50
900	920	1075	48	26	1020	980	5	24	M27	30	79,80	40,80
1000	1022	1175	52	26	1120	1080	5	28	M27	30	94,00	44,00
1100	1126	1300	54	28	1240	1202	5	28	M30	33	136,00	64,00
1200	1225	1405	60	28	1340	1295	5	32	M30	33	153,00	67,00
1300	1326	1520	65	30	1450	1400	5	32	M33	36	199,00	85,00
1400	1426	1630	72	32	1560	1510	5	36	M33	36	246,00	104,00
1500	1526	1730	74	32	1660	1610	5	36	M33	36	273,00	109,00
1600	1626	1830	80	34	1760	1710	5	40	M33	36	311,00	126,00
1800	1826	2045	88	36	1970	1920	5	44	M36	39	411,00	160,00
2000	2026	2265	96	38	2180	2125	5	48	M39	42	541,00	204,00
2200	2226	2475	Upon Customer Request It will be determined.	42	2390	2335	5	52	M39	42	-	273,00
2400	2426	2685		44	2600	2545	5	56	M39	42	-	323,00

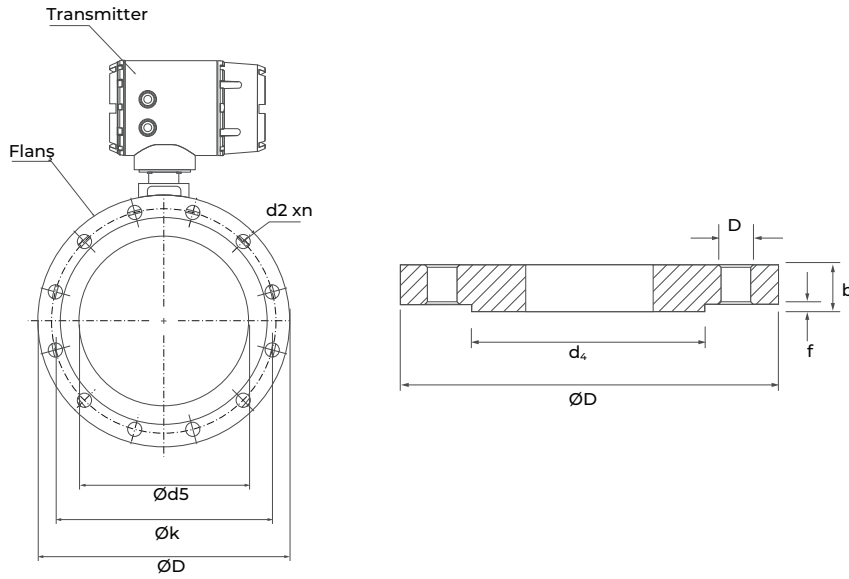

Pn 10 Steel Flat Flange  
TS-EN 1092-1/  
TYPE 01 / DIN 2576

PIPE	FLANGE					ALIN ÇIKINTISI		HOLES			WEIGHT	
	DN	ds	D	b		k	d4	f	n	screw	d2	EN 1092 - 1 kg/ad - kg/pcs
			EN 1092-1	DIN2501								
15	22	95	14	14	65	45	2	4	M12	14	0,59	0,59
20	27,5	105	16	16	75	58	2	4	M12	14	0,85	0,85
25	34,5	115	16	16	85	68	2	4	M12	14	1,01	1,01
32	43,5	140	18	16	100	78	2	4	M16	18	1,70	1,50
40	49,5	150	18	16	110	88	3	4	M16	18	1,80	1,60
50	61,5	165	20	18	125	102	3	4	M16	18	2,50	2,20
65	77,5	185	20	18	145	122	3	(1092)8/4 (DIN)	M16	18	3,00	2,70
80	90,5	200	20	20	160	138	3	8	M16	18	3,30	3,30
100	116	220	22	20	180	158	3	8	M16	18	4,00	3,60
125	141,5	250	22	22	210	188	3	8	M16	18	5,00	5,00
150	170,5	285	24	22	240	212	3	8	M20	22	6,50	6,00
200	221,5	340	24	24	295	268	3	8	M20	22	8,50	8,50
250	276,5	395	26	26	350	320	3	12	M20	22	11,00	11,00
300	327,5	445	26	26	400	370	4	12	M20	22	12,30	12,30
350	359,5	505	30	26	460	430	4	16	M20	22	20,30	17,40
400	411	565	32	26	515	482	4	16	M24	26	25,70	2,50
450	462	615	36	28	565	532	4	20	M24	26	31,50	22,20
500	513,5	670	38	28	620	585	4	20	M24	26	37,90	27,30
550	564	730	40	28	675	635	5	20	M24	26	47,60	33,00
600	616,5	780	42	28	725	685	5	20	M27	30	50,80	32,60
700	718	895	50	30	840	800	5	24	M27	30	77,10	44,50
800	819	1015	56	32	950	905	5	24	M30	33	109,50	60,10
900	920	1115	62	34	1050	1005	5	28	M30	33	133,90	70,60
1000	1022	1230	70	34	1160	1110	5	28	M33	36	179,00	83,00
1100	1126	1340	76	36	1270	1220	5	32	M33	36	224,00	102,00
1200	1225	1455	83	38	1380	1330	5	32	M36	39	280,00	123,00
1300	1326	1575	Upon Customer Request it will be determined.	38	1490	1440	5	32	M39	42	-	145,00
1400	1426	1675		42	1590	1535	5	36	M39	42	-	172,00
1500	1530	1785		44	1700	1648	5	36	M39	42	-	200,00
1600	1626	1915		46	1820	1760	5	40	M45	48	-	250,00
1800	1826	2115		50	2020	1960	5	44	M45	48	-	304,00
2000	2026	2325		54	2230	2170	5	48	M45	48	-	379,00
2200	2226	2550		58	2440	2370	5	52	M52	55	-	491,00
2400	2426	2760		62	2650	2570	5	56	M52	55	-	592,00
2600	2626	2960		66	2680	2780	5	60	M52	55	-	678,00

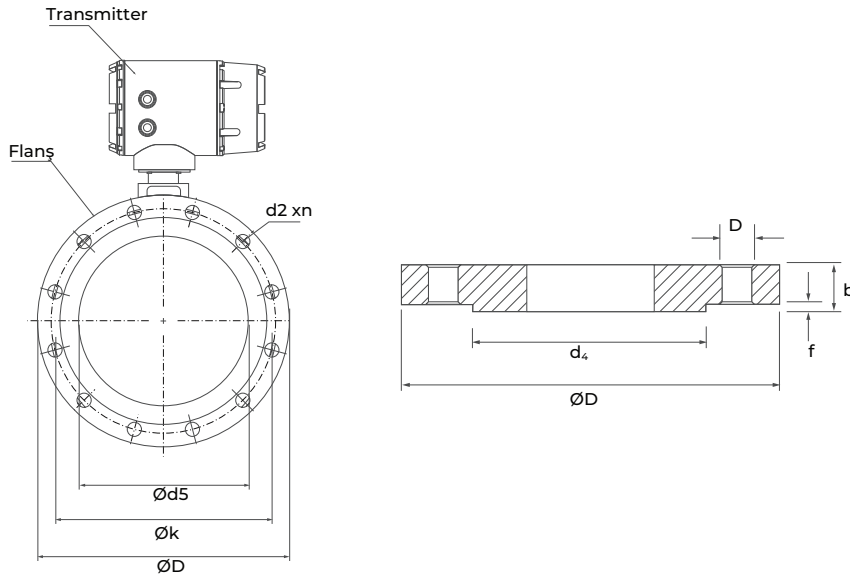

Pn 16 Steel Flat Flange  
TS-EN 1092-1/  
TYPE 01 / DIN 2576

PIPE	FLANGE					ALIN ÇIKINTISI		HOLES			WEIGHT	
	DN	ds	D	b		k	d4	f	n	screw	d2	EN 1092 - 1 kg/ad - kg/pcs
			EN 1092-1	DIN2501								
15	22	95	14	14	65	45	2	4	M12	14	0,59	0,69
20	27,5	105	16	16	75	58	2	4	M12	14	0,85	0,97
25	34,5	115	16	16	85	68	2	4	M12	14	1,01	1,15
32	43,5	140	18	18	100	78	2	4	M16	18	1,68	1,68
40	49,5	150	18	18	110	88	3	4	M16	18	1,80	1,80
50	61,5	165	20	20	125	102	3	4	M16	18	2,50	2,50
65	77,5	185	22	22	145	122	3	8	M16	18	3,20	3,20
80	90,5	200	24	24	160	138	3	8	M16	18	4,00	4,00
100	116	235	26	24	190	162	3	8	M20	22	5,60	5,20
125	141,5	270	28	26	220	188	3	8	M24	26	7,60	7,00
150	170,5	300	30	28	250	218	3	8	M24	26	9,60	8,90
200	221,5	360	32	30	310	278	3	12	M24	26	13,50	12,60
250	276,5	425	35	32	370	335	3	12	M27	30	19,10	17,40
300	327,5	485	38	34	430	395	4	16	M27	30	25,00	22,20
350	359,5	555	42	38	490	450	4	16	M30	33	39,60	35,60
400	411	620	48	40	550	505	4	16	M33	36	55,00	45,40
450	462	670	54	42	600	555	4	20	M33	36	66,90	51,40
500	513,5	730	58	44	660	615	4	20	M33	36	83,90	62,80
600	616,5	845	68	46	770	720	5	20	M36	39	122,00	81,00
700	718	960	85	46	875	820	5	24	M39	42	184,00	97,00
800	819	1085	95	50	990	930	5	24	M45	48	257,00	131,00
900	920	1185	Upon Customer Request It will be determined.	54	1090	1030	5	28	M45	48	-	156,00
1000	1022	1320		58	1210	1140	5	28	M52	56	-	207,00
1100	1122	1420		66	1310	1240	5	32	M52	56	-	256,00
1200	1225	1530		70	1420	1350	5	32	M52	56	-	306,00
1300	1326	1640		74	1530	1455	5	32	M58	62	-	355,00
1400	1426	1755		76	1640	1560	5	36	M58	62	-	410,00
1500	1530	1865		84	1740	1670	5	36	M58	62	-	501,00
1600	1626	1975		90	1860	1780	5	40	M58	62	-	595,00
1800	1826	2195		96	2070	1985	5	44	M64	70	-	731,00
2000	2026	2425		102	2300	2210	5	48	M64	70	-	884,00

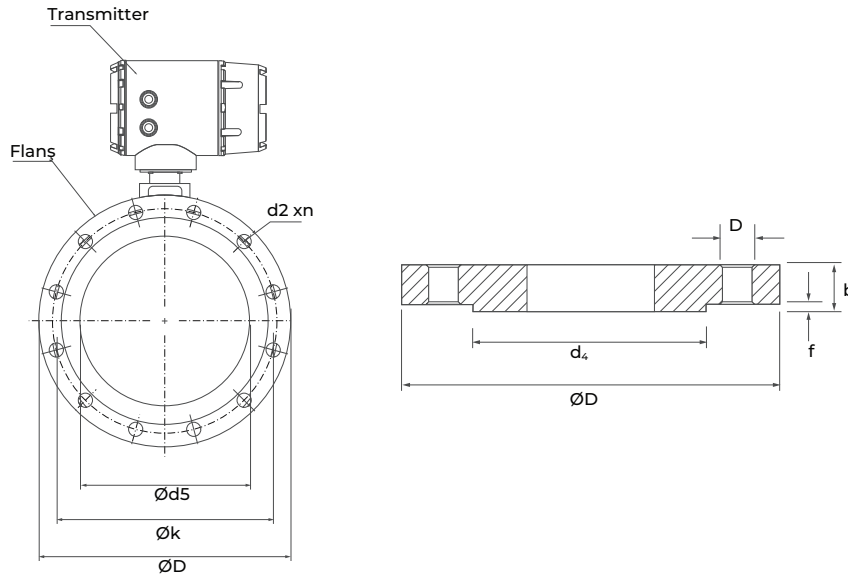

Pn 25 Steel Flat Flange  
TS-EN 1092-1/  
TYPE 01 / DIN 2576

PIPE	FLANGE					ALIN ÇIKINTISI		HOLES			WEIGHT	
	DN	ds	D	b		k	d4	f	n	screw	d2	EN 1092 - 1 kg/ad - kg/pcs
			EN 1092-1	DIN2501								
15	22	95	14	14	65	45	2	4	M12	14	0,59	0,69
20	27,5	105	16	16	75	58	2	4	M12	14	0,85	0,97
25	34,5	115	16	16	85	68	2	4	M12	14	1,01	1,15
32	43,5	140	18	18	100	78	2	4	M16	18	1,68	1,68
40	49,5	150	18	18	110	88	3	4	M16	18	1,80	1,80
50	61,5	165	20	20	125	102	3	4	M16	18	2,50	2,50
65	77,5	185	22	22	145	122	3	8	M16	18	3,20	3,20
80	90,5	200	24	24	160	138	3	8	M16	18	4,00	4,00
100	116	235	26	24	190	162	3	8	M20	22	5,60	5,20
125	141,5	270	28	26	220	188	3	8	M24	26	7,60	7,00
150	170,5	300	30	28	250	218	3	8	M24	26	9,60	8,90
200	221,5	360	32	30	310	278	3	12	M24	26	13,50	12,60
250	276,5	425	35	32	370	335	3	12	M27	30	19,10	17,40
300	327,5	485	38	34	430	395	4	16	M27	30	25,00	22,20
350	359,5	555	42	38	490	450	4	16	M30	33	39,60	35,60
400	411	620	48	40	550	505	4	16	M33	36	55,00	45,40
450	462	670	54	42	600	555	4	20	M33	36	66,90	51,40
500	513,5	730	58	44	660	615	4	20	M33	36	83,90	62,80
600	616,5	845	68	46	770	720	5	20	M36	39	122,00	81,00
700	718	960	85	46	875	820	5	24	M39	42	184,00	97,00
800	819	1085	95	50	990	930	5	24	M45	48	257,00	131,00
900	920	1185	Upon Customer Request It will be determined.	54	1090	1030	5	28	M45	48	-	156,00
1000	1022	1320		58	1210	1140	5	28	M52	56	-	207,00
1100	1122	1420		66	1310	1240	5	32	M52	56	-	256,00
1200	1225	1530		70	1420	1350	5	32	M52	56	-	306,00
1300	1326	1640		74	1530	1455	5	32	M58	62	-	355,00
1400	1426	1755		76	1640	1560	5	36	M58	62	-	410,00
1500	1530	1865		84	1740	1670	5	36	M58	62	-	501,00
1600	1626	1975		90	1860	1780	5	40	M58	62	-	595,00
1800	1826	2195		96	2070	1985	5	44	M64	70	-	731,00
2000	2026	2425		102	2300	2210	5	48	M64	70	-	884,00

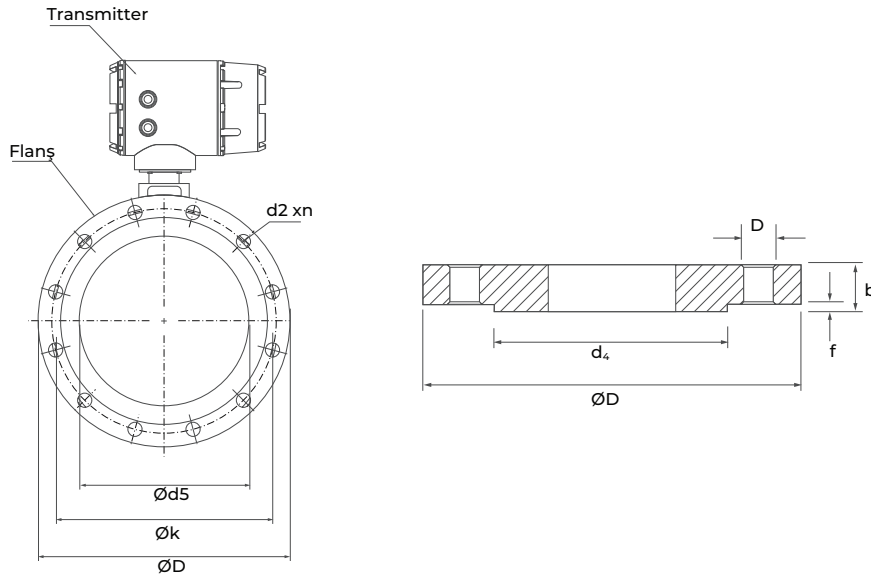

Pn 40 Steel Flat Flange  
TS-EN 1092-1/  
TYPE 01 / DIN 2576

PIPE	FLANGE					ALIN ÇIKINTISI		HOLES			WEIGHT	
	DN	ds	D	b		k	d4	f	n	screw	d2	EN 1092 - 1 kg/ad - kg/pcs
			EN 1092-1	DIN2501								
15	22	95	14	14	65	45	2	4	M12	14	0,59	0,69
20	27,5	105	16	16	75	58	2	4	M12	14	0,85	0,97
25	34,5	115	16	16	85	68	2	4	M12	14	1,01	1,15
32	43,5	140	18	18	100	78	2	4	M16	18	1,67	1,67
40	49,5	150	18	18	110	88	3	4	M16	18	1,80	1,80
50	61,5	165	20	20	125	102	3	4	M16	18	2,40	2,40
65	77,5	185	22	22	145	122	3	8	M16	18	3,20	3,20
80	90,5	200	24	24	160	138	3	8	M16	18	4,00	4,00
100	116	235	26	24	190	162	3	8	M20	22	5,60	5,10
125	141,5	270	28	26	220	188	3	8	M24	26	7,60	7,00
150	170,5	300	30	28	250	218	3	8	M24	26	9,60	8,90
200	221,5	375	36	34	320	285	3	12	M27	30	17,00	16,00
250	276,5	450	42	38	385	345	3	12	M30	33	28,00	25,20
300	327,5	515	52	42	450	410	4	16	M30	33	43,10	34,50
350	359,5	580	58	46	510	465	4	16	M33	36	64,30	50,50
400	411	660	65	50	585	535	4	16	M36	39	94,10	71,70
450	462	685		50	610	560	4	20	M36	39	-	69,00
500	513,5	755		52	670	615	4	20	M39	42	-	83,10
600	616,5	890		60	795	735	5	20	M45	48	-	129,00
700	718	995		64	900	848	5	24	M45	48	-	159,00
800	819	1140		72	1030	970	5	24	M52	56	-	237,00
900	920	1250		76	1140	1080	5	28	M52	56	-	285,00
1000	1022	1360		80	1250	1190	5	28	M52	56	-	343,00
1200	1224	1575		88	1460	1394	5	32	M58	62	-	454,00
1300	1324	1685		94	1570	1504	5	32	M58	62	-	545,00
1400	1424	1795		98	1680	1614	5	36	M58	62	-	624,00
1500	1528	1910		104	1790	1722	5	36	M60	64	-	732,00
1600	1624	2025		108	1900	1826	5	40	M66	70	-	827,00

Upon Customer Request  
It will be determined.

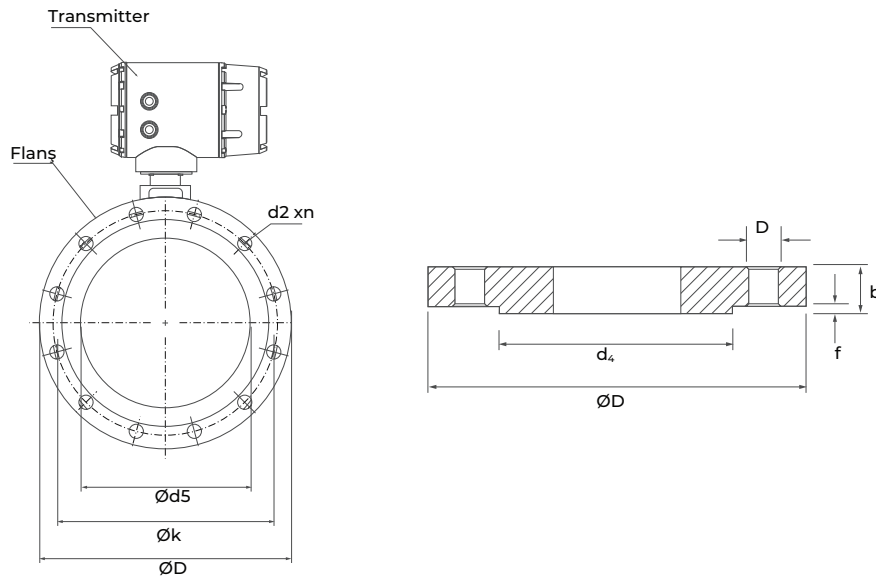

Pn 64 Steel Flat Flange  
TS-EN 1092-1/  
TYPE 01 / DIN 2576

PIPE	FLANGE					ALIN ÇIKINTISI		HOLES			WEIGHT	
	DN	ds	D	b		k	d4	f	n	screw	d2	EN 1092 - 1 kg/ad - kg/pcs
15	22	105	20	20	75	45	2	4	M12	14	1,10	1,10
20	27,5	130	22	22	90	58	2	4	M16	18	1,86	1,86
25	34,5	140	24	24	100	68	2	4	M16	18	2,37	2,37
32	43,1	155	24	24	110	78	3	4	M20	22	2,70	2,70
40	49	170	26	26	125	88	3	4	M20	22	3,60	3,60
50	61,1	180	26	26	135	102	3	4	M20	22	3,90	3,90
65	71,1	205	26	26	160	122	3	8	M20	22	4,70	4,70
80	90,3	215	30	28	170	138	3	8	M20	22	5,90	5,50
100	115,9	250	32	30	200	162	3	8	M24	26	8,00	7,50
125	141,6	295	34	34	240	188	3	8	M27	30	11,70	11,70
150	170,5	345	36	36	280	218	3	8	M30	33	16,90	16,90
200	221,5	415	48	42	345	285	3	12	M33	36	30,50	26,50
250	276,2	470	55	46	400	345	3	12	M33	36	42,20	35,00
300	327,6	530	65	52	460	410	4	16	M33	36	59,00	46,80
350	359,7	600	72	56	525	465	4	16	M36	39	88,70	68,30
400	411	670	80	60	585	535	4	16	M39	42	120,90	89,90
500	513,5	800	Upon Customer Request It will be determined.	60	705	615	4	20	M45	48	-	117,00
600	616,5	930		62	820	735	5	20	M52	56	-	155,00
700	718	1045		68	935	840	5	24	M52	56	-	203,00
800	819	1165		76	1050	960	5	24	M58	62	-	270,00
900	920	1285		84	1170	1070	5	28	M58	62	-	352,00
1000	1022	1415		92	1290	1180	5	28	M66	70	-	454,00
1200	1226	1665		100	1530	1380	5	32	M74	78	-	646,00

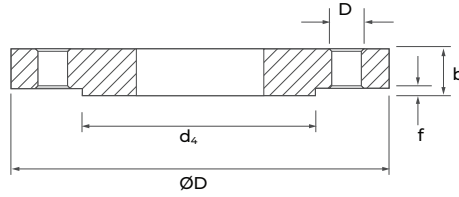
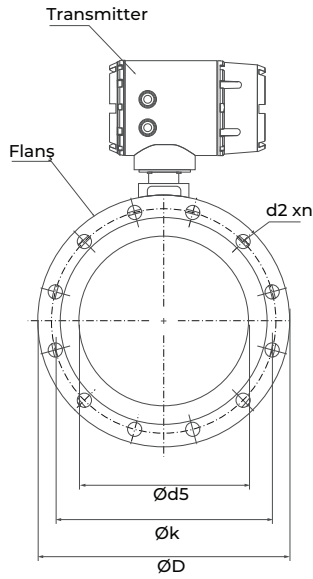

Pn 100 Steel Flat Flange  
TS-EN 1092-1/  
TYPE 01 / DIN 2576

PIPE	FLANGE					ALIN ÇIKINTISI		HOLES			WEIGHT	
	DN	ds	D	b		k	d4	f	n	screw	d2	EN 1092 - 1 kg/ad - kg/pcs
15	22	105	20	20	75	45	2	4	M12	14	1,10	1,10
20	27,6	130	22	22	90	58	2	4	M16	18	1,86	1,86
25	34,4	140	24	24	100	68	2	4	M16	18	2,37	2,37
32	43,1	155	24	24	110	78	3	4	M20	22	2,70	2,70
40	49	170	26	26	125	88	3	4	M20	22	3,58	3,58
50	61,1	195	28	28	145	102	3	4	M24	26	5,00	5,00
65	77,1	220	30	30	170	122	3	8	M24	26	6,34	6,34
80	90,3	230	34	32	180	138	3	8	M24	26	7,73	7,24
100	115,9	265	36	36	210	162	3	8	M27	30	10,33	10,30
125	141,6	315	42	40	250	188	3	8	M30	33	17,24	16,40
150	170,5	355	48	44	290	218	3	12	M30	33	23,63	21,60
200	221,5	430	60	52	360	285	3	12	M33	36	42,90	37,00
250	276,2	505	72	60	430	345	3	12	M36	39	69,12	57,20
300	327,6	585	84	68	500	410	4	16	M39	42	103,52	83,10
350	359,7	655	95	74	560	465	4	16	M45	48	149,69	115,60

## TERMS OF USE



1. The following conditions must be met to ensure accurate and reliable measurement in Kare Compact Series electromagnetic flowmeters:
2. The tested liquid must have a conductivity of 5  $\mu$ S or higher.
3. The pipe must be completely full.
4. The components in the liquid must be homogeneously mixed.
5. If the liquid induces magnetism, the device's magnetic field will change, requiring the device to be recalibrated.
6. Installation methods suitable for laminar flow must be used.
7. Installation must be carried out with grounding rings and grounding connections on plastic and insulated pipes.
8. Grounding connections must be made regardless of the type of pipe.



The dimensions of the flanged sensor's grounding ring are between 15 and 300 mm.

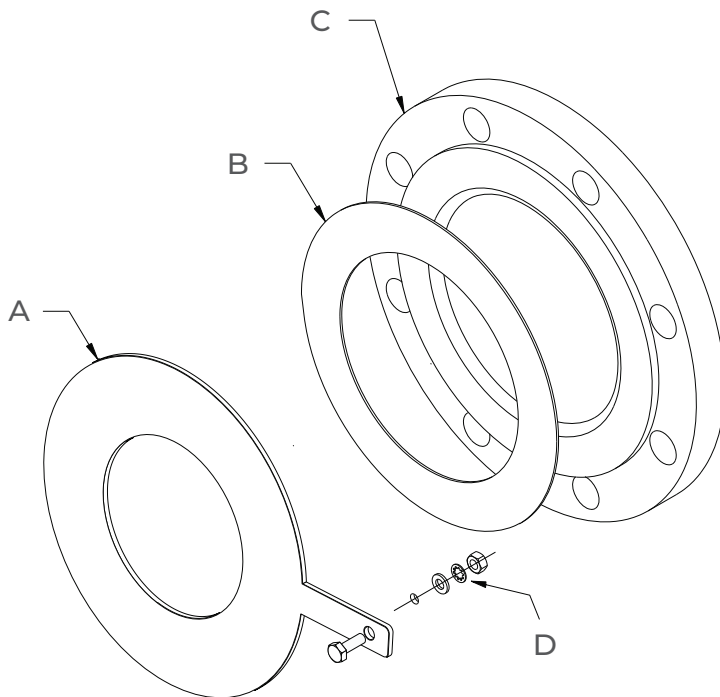

- A. Grounding ring
- B. Gasket provided by the customer
- C. Measurement flange
- D. Screw

DN	Thickness of the grounding ring
15	2
20	2
25	2
32	2
40	2
50	2
65	2
80	2
100	2
125	2
150	2
200	2
250	2
300	2

**INSTALLATION METHODS**

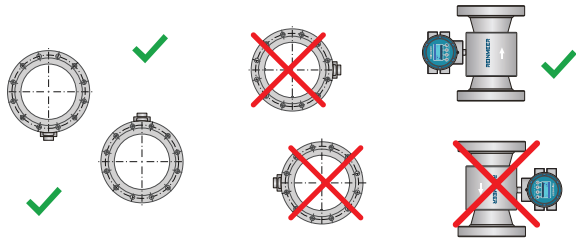
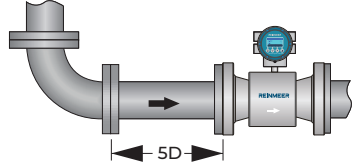
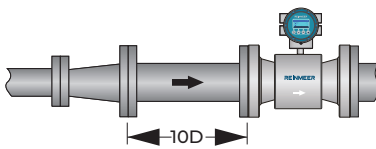
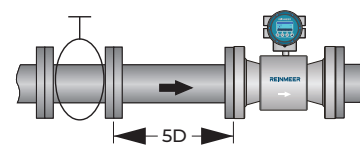
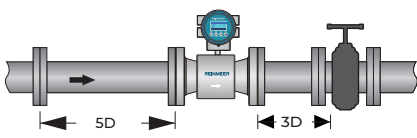
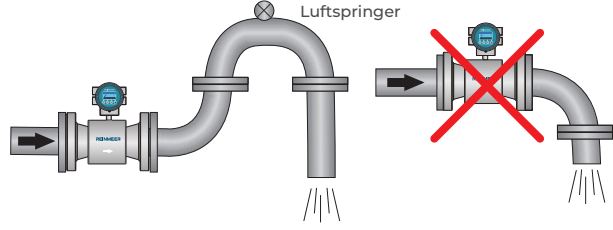
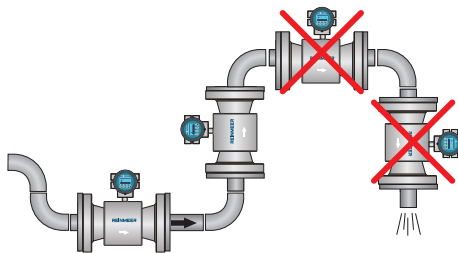
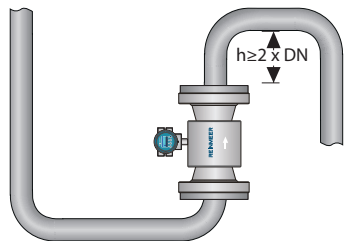
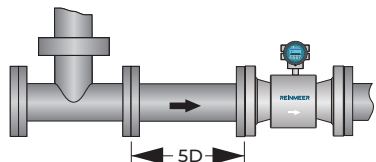
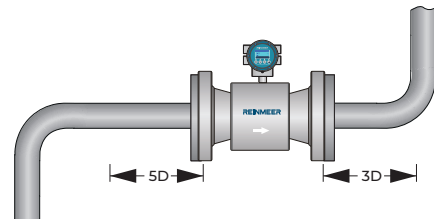
<p><b>Installation Method</b></p> 	<p><b>90° Elbow</b></p> 
<p><b>Expansion Pipe</b></p> 	<p><b>Various Valves</b></p> 
<p><b>Valve Fully Open Position</b></p> 	<p><b>Installation on Open-Ended Lines</b></p> 
<p><b>Installation in Bent Pipes</b></p> 	<p><b>Entry-Exit Installation Application</b></p> 
<p><b>T-Shaped Pipe</b></p> 	<p><b>Input-Output Assembly Application</b></p> 

<p><b>Installation in Partially Filled Systems</b></p>	
<p><b>Installation in the Pump Process</b></p>	
<p><b>Grounding Line</b></p> <p>The use of a grounding ring is mandatory in plastic lines and lines with internal insulation.</p>	<p><b>Grounding Connection</b></p>
<p><b>Avoid Magnetic Fields</b></p>	<p><b>Avoid Vibration</b></p>

**DN100 (4'')** / **EN** - **PL** - **D16C** - **GE** - **MT** - **023** - **R3** - **SI20** - **DC** - **M2R** - **GSM**

1  
 2  
 3  
 4  
 5  
 6  
 7  
 8  
 9  
 10  
 11

**1 Interior Lining Material**

Ebonite	<input checked="" type="checkbox"/>	<b>EN</b>
EPDM (Soft Rubber)	<input type="checkbox"/>	<b>SR</b>
PTFE	<input type="checkbox"/>	<b>PT</b>
Black PTFE	<input type="checkbox"/>	<b>BPT</b>
Ceramic	<input type="checkbox"/>	<b>CR</b>

**2 Electrode Material**

316 Stainless Steel	<input type="checkbox"/>	<b>SS</b>
Hastelloy C22	<input type="checkbox"/>	<b>HC</b>
Platinum Rhodium	<input checked="" type="checkbox"/>	<b>PL</b>
Tantalum	<input type="checkbox"/>	<b>TA</b>
Titanium	<input type="checkbox"/>	<b>Ti</b>

**3 Process Connection**

PN40, EN1092-1 Flange, St37-2	<input type="checkbox"/>	<b>D40C</b>
PN25, EN1092-1 Flange, St37-2	<input type="checkbox"/>	<b>D25C</b>
PN16, EN1092-1 Flange, St37-2	<input checked="" type="checkbox"/>	<b>D16C</b>
PN10, EN1092-1 Flange, St37-2	<input type="checkbox"/>	<b>D10C</b>
PN6, EN1092-1 Flange, St37-2	<input type="checkbox"/>	<b>D6C</b>
Class 300 RF ANSI Flange, St37-2	<input type="checkbox"/>	<b>A30C</b>
Class 150 RF ANSI Flange, St37-2	<input type="checkbox"/>	<b>A15C</b>
PN40, EN1092-1 Flange, SS 316L	<input type="checkbox"/>	<b>D40S</b>
PN25, EN1092-1 Flange, SS 316L	<input type="checkbox"/>	<b>D25S</b>
PN16, EN1092-1 Flange, SS 316L	<input type="checkbox"/>	<b>D16S</b>
PN10, EN1092-1 Flange, SS 316L	<input type="checkbox"/>	<b>D10S</b>
PN6 EN1092-1 Flange, SS 316L	<input type="checkbox"/>	<b>D6S</b>
Class 300 RF ANSI Flange, SS 316L	<input type="checkbox"/>	<b>A30S</b>
Class 150 RF ANSI Flange, SS 316L	<input type="checkbox"/>	<b>A15S</b>
Tri-Clamp Connection, SS 316L	<input type="checkbox"/>	<b>TRIS</b>
DIN 11851 Hygienic Connection. 1.4404 (316L)	<input type="checkbox"/>	<b>SANS</b>

**4 Grounding**

Standard 3. Electrode	<input type="checkbox"/>	<b>XX</b>
Grounding Ring	<input checked="" type="checkbox"/>	<b>GE</b>
316L Grounding Ring	<input type="checkbox"/>	<b>GESS</b>
Hastelloy C22	<input type="checkbox"/>	<b>GEHC</b>

**6 Calibration**

Dry Calibration, standard	<input type="checkbox"/>	<b>000</b>
0.5% factory calibrated with 3 points	<input type="checkbox"/>	<b>053</b>
0.5% 5-point factory calibrated	<input type="checkbox"/>	<b>055</b>
0.2% 3-point 17025 Accreditation	<input checked="" type="checkbox"/>	<b>023</b>
0.5% 5-point 17025 Accreditation	<input type="checkbox"/>	<b>025</b>

**7 Transmitter Type, Protection Class**

Compact, IP67	<input type="checkbox"/>	<b>C1</b>
Compact, IP67 (Rectangular)	<input type="checkbox"/>	<b>C2</b>
Separate, IP67 (Rectangular)	<input checked="" type="checkbox"/>	<b>R1</b>

**8 Cable Length (for Separate Type)**

None	<input type="checkbox"/>	<b>XX</b>
5-meter signal cable	<input type="checkbox"/>	<b>5</b>
10-meter signal cable	<input type="checkbox"/>	<b>10</b>
20-meter signal cable	<input type="checkbox"/>	<b>20</b>
30-meter signal cable	<input type="checkbox"/>	<b>30</b>
40-meter signal cable	<input type="checkbox"/>	<b>40</b>
Additional 1 meter signal cable	<input type="checkbox"/>	<b>XX</b>
LP-20 7-Pin S-0/P-E Screw-On IP68 Plug and Play 5-meter signal cable	<input type="checkbox"/>	<b>SI5</b>
LP-20 7-Pin S-D/P-E Screw-On IP68 Plug and Play 10-meter signal cable	<input type="checkbox"/>	<b>SI10</b>
LP-20 7-Pin S-0/P-E Screw-On IP68 Plug and Play 20-meter signal cable	<input checked="" type="checkbox"/>	<b>SI20</b>
LP-20 7-Pin S-0/P-E Screw-On IP68 Plug and Play 30-meter signal cable	<input type="checkbox"/>	<b>SI30</b>
LP-20 7-Pin S-0/P-E Screw-On IP68 Plug and Play 40-meter signal cable	<input type="checkbox"/>	<b>SI40</b>

**9 Supply Voltage**

Battery-powered	<input type="checkbox"/>	<b>BT</b>
80 ... 230 VAC (48 ... 60 Hz)	<input type="checkbox"/>	<b>AC</b>
8 ... 36VDC	<input checked="" type="checkbox"/>	<b>DC</b>

**10 Output Signal**

4...20 mA, RS485 MODBUS, pulse, alarm, status	<input checked="" type="checkbox"/>	<b>M2R</b>
4...20 mA, HART, pulse, alarm, status	<input type="checkbox"/>	<b>M2H</b>
PROFIBUS (Only with rectangular transmitter)	<input type="checkbox"/>	<b>M2P</b>

**11 Option 1**

Does not require straight pipe	<input type="checkbox"/>	<b>MXD</b>
--------------------------------	--------------------------	------------

**Option 2**

Stainless Steel Body	<input type="checkbox"/>	<b>SSB</b>
Stainless Steel Body + Stainless Steel Housing	<input type="checkbox"/>	<b>SSBF</b>
Stainless Steel Flange	<input type="checkbox"/>	<b>SSPF</b>

**Option 3**

Internal GSM Data Logger (Only with rectangular transmitter)	<input checked="" type="checkbox"/>	<b>GSM</b>
--	-------------------------------------	------------

# Contact us



Reinmeer Factory Address  
Eutiner Str.12,22143  
Hamburg, Germany  
[reinmeer@reinmeer.com](mailto:reinmeer@reinmeer.com)