

REINMEER

www.reinmeer.com



REINMEER ELECTROMAGNETIC FLOWMETER

Bluetooth | WiFi | LoRaWAN* | 4G

RELIABLE MEASUREMENTS FOR
CORRECT DECISIONS.

REINMEER

ELECTROMAGNETIC FLOWMETER

Bluetooth | WiFi | LoRaWAN | 4G

REMOTE ACCESS AND CONTROL

BACKLIGHT GRAPHIC LCD SCREEN

TOUCH CAPACITIVE BUTTON PANEL

TEFLON / EBONITE / EPDM INTERIOR COATING OPTIONS

CORROSION-RESISTANT OUTER COATING

DIE-CAST ALUMINUM MOLD BODY

65.000 Data Memory



4G

www.reinmeer.com

WORKING PRINCIPLE

Electromagnetic flow measurement: This is a flow measurement method based on the principle of the electromagnetic field.

The physical foundations of this principle are based on the discovery made by English physicist Michael Faraday in 1831, who found that an electric current could be generated with the help of a magnetic field. In 1941, Swiss scientist Bonaventura Thurlemann applied this knowledge to conductive liquids flowing through pipes and produced the world's first electromagnetic flowmeter.

The Reinmeer Series electromagnetic flowmeter contains two coils. These coils, with the help of metal blocks placed on them, create a continuous magnetic field across the cross-sectional area of the measurement tube. Two electrodes that detect voltage are placed perpendicular to each other inside the measurement tube. The insulating material coated on the inner surface prevents the formation of short circuits between the conductive liquid and the metal measurement tube.

When there is no flow, no electrical voltage is generated between the two electrodes. In the conductive liquid, negatively and positively charged ions are present in equal amounts. When flow starts, the magnetic field applies a force to the charged ion particles in the liquid. As a result, the negatively and positively charged ions move apart and head toward opposite sides of the measurement tube. This leads to an electrical voltage detected by the electrodes.

This voltage is directly proportional to the flow rate within the pipe. With the known volume and speed information of the measurement tube, the instantaneous flow rate can be calculated. As the flow rate increases, the separation of charged particles also increases, and thus, the voltage between the electrodes will rise.

The measurement electrodes may sometimes detect magnetic noise present in the environment. It is essential to differentiate this noise signal from the actual measurement signal. To achieve this, the magnetic field must be generated with pulsed direct current. With pulsed direct current, the positions of the charged ions between the electrodes are continuously shifted, eliminating the effect of magnetic noise, allowing for precise and stable flow measurement.

Flow rate information with the electromagnetic measurement principle is calculated using the simplified formula below.

- $U_e = B \cdot L \cdot v$
- B = Magnetic induction (magnetic field)
- L = Distance between the electrodes
- v = Flow velocity
- Q = Volumetric flow rate
- A = Pipe cross-section

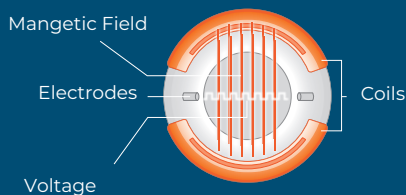
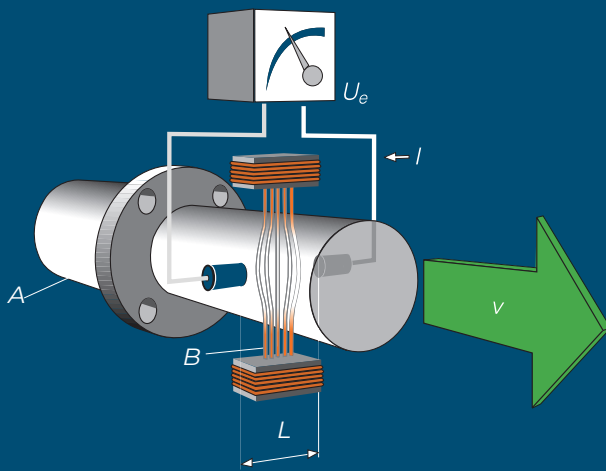

Induced voltage proportional to flow

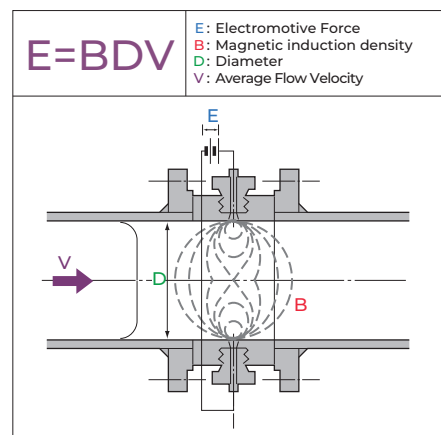

APPLICATION AREAS

Reinmeer Series electromagnetic flowmeters can be easily used for volumetric flow measurements of water and wastewater applications, as well as any water-based or conductive liquids.

In addition, with a wide range of internal coating and electrode material options, they offer reliable solutions for volumetric flow measurement of acids, alkalis, and corrosive chemicals used in the industry. Furthermore, electromagnetic flowmeters are widely used in the mining and paper industries for volumetric flow measurements of special products like ores, sludges, slurries, pastes, and pulps.

Since there are no moving parts in the Reinmeer Series electromagnetic flowmeter, it does not cause any changes in process pressure, and maintenance costs are very low. Additionally, thanks to this feature, it provides "full passage" and has a very wide measurement range.

Chemical Industry



Agriculture



Food & Beverages



Water and Wastewater



Paper Industry



Mining



APPLICATION

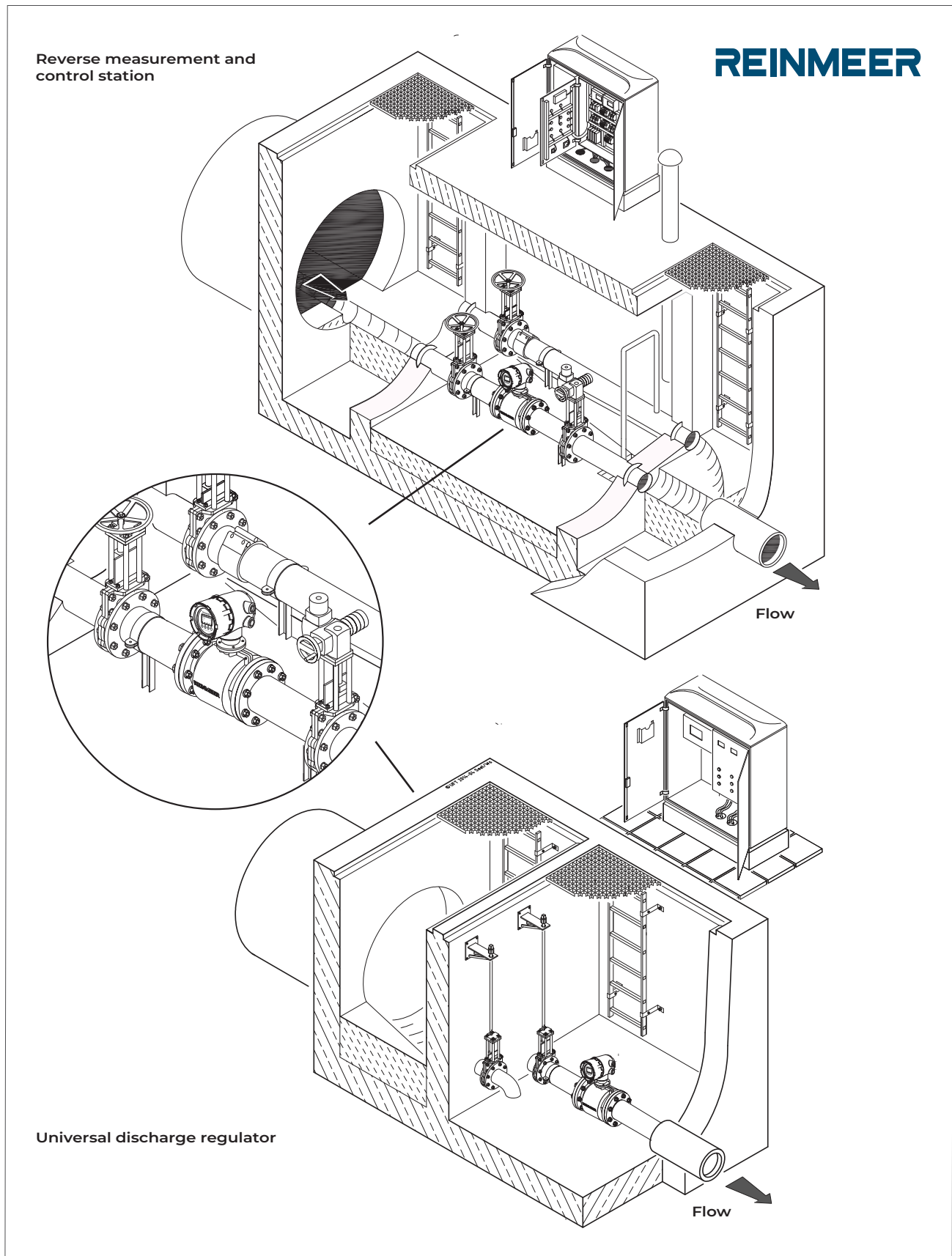

TECHNICAL DRAWING

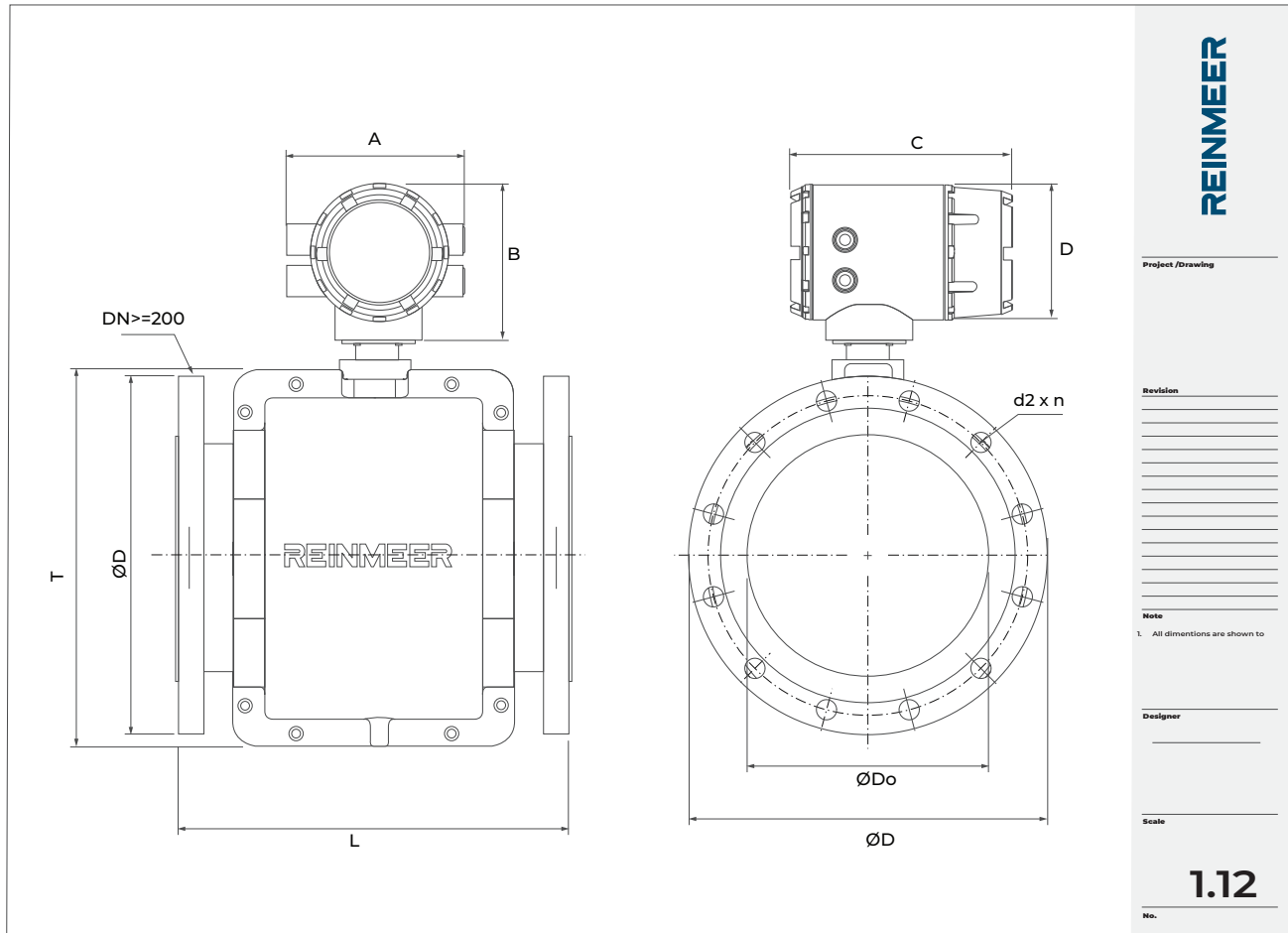

TRANSMITTER

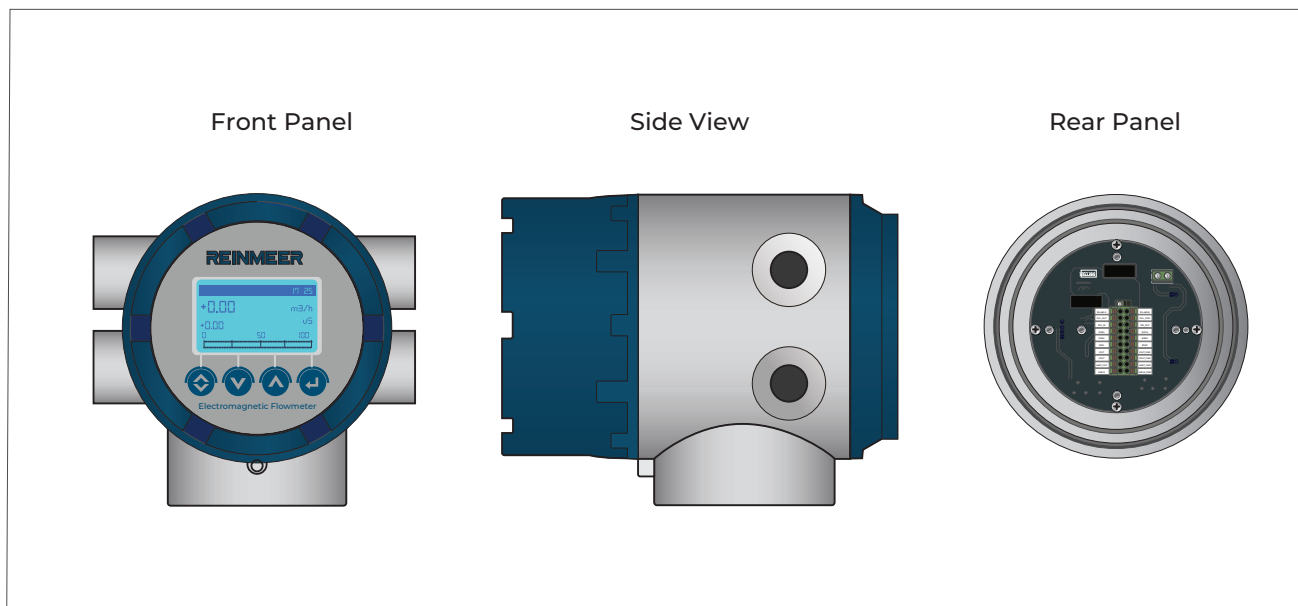

TECHNICAL SPECIFICATIONS

BODY

Body Structure	Die-cast aluminum mold (standard)	Stainless Steel 1.4301 (Optional)
Measurement Tube Material	316 Stainless Steel	
Nominal Diameters	DN15 - DN300 DIN EN 1092-1 From B ½" ... 12" ASME 16,5 RF	
Flange Material	Alloy Steel ST 37-2 (Standard)	Stainless Steel 1.4301 (Optional)
Nominal Pressures	DN15-DN80	PN 40 (standard) PN16, PN25, PN10 (Optional)
	DN100-DN150	PN 16 (standard) PN10, PN25, PN40 (Optional)
	DN200-DN300	PN 10 (standard) PN16, PN25, PN40,PN6 (Optional)
Process Temperature	-10 ... +80 °C	Ebonite
	-10 ... +70 °C	EPDM (Soft Rubber)
	-20 ... +150 °C	PTFE
	-20 ... +120 °C	Black PTFE
	-40 ... +180 °C	Ceramic
Internal Lining Material	Ebonite, EPDM, PTFE, Black PTFE, Ceramic	
Measurement Electrode Mat.	316 Stainless Steel, Hastelloy C22, Tantalum, Titanium, Platinum Rhodium	
Grounding Electrode Mat.	316 Stainless Steel, Hastelloy C22, Tantalum, Titanium, Platinum Rhodium	
Grounding Ring	The grounding ring should be preferred when the pipe material is made of plastic.	
Process Conductivity	≥ 5 µS/cm	
Measurement Speed Range	0,02 ... 12 m/s	
Accuracy	% 0.2	
Protection Class	IP67 (Compact Model) / IP68 (Separated Model)	

Transmitter

Body Material	Die-cast Aluminum	
Mounting Type	Compact or Remote	
Local Display	220 VAC / 24 VDC (one can be selected)	Battery (optional)
Local Display	Backlight LCD Display 64x128	
Display Languages	English, German, Spanish (2 languages can be selected)	
Output Signals	Standard (4-20 mA, 0-10V, Frequency, Pulse) Alarm/Status = 2 x Relay Output	
Digital Input	Flow reading start/stop / Clear errors / Reset total flow	
Temperature	-20 ... +70 °C (Depending on process temperature)	
Communications	RS485 MODBUS (Standard) Wifi, Bluetooth, (Standard)	HART,PROFIBUS (Optional) LoraWAN,4G (Optional)
Data Logging	Datalogger with 65,000 data memory	
Protection Class	IP67	

POSITION OF FLANGE SEALS

! It is mandatory to use a grounding ring in plastic lines and in lines with pipe insulation.

A
Grounding Ring

B
Gasket

FLOW

In piping systems without grounding, the grounding ring should be mounted between the sensor flange and the pipe.
Material: SS 316 or Hastelloy C
Thickness: 2 mm for SS 316 / 1 mm for Hastelloy C

REINMEER

Project /Drawing _____

Revision _____

Note
1. All dimensions are shown to _____

Designer _____

Scale _____

1.12

No. _____

! It is mandatory to use a grounding ring in plastic lines and in lines with pipe insulation.

Grounding Ring

Non-conductive pipeline

REINMEER

Grounding of a Flowmeter in a Non-Conductive Pipe.

REINMEER

Project /Drawing _____

Revision _____

Note
1. All dimensions are shown to _____

Designer _____

Scale _____

1.12

No. _____

FLOW RATE / DIAMETER / VELOCITY TABLE

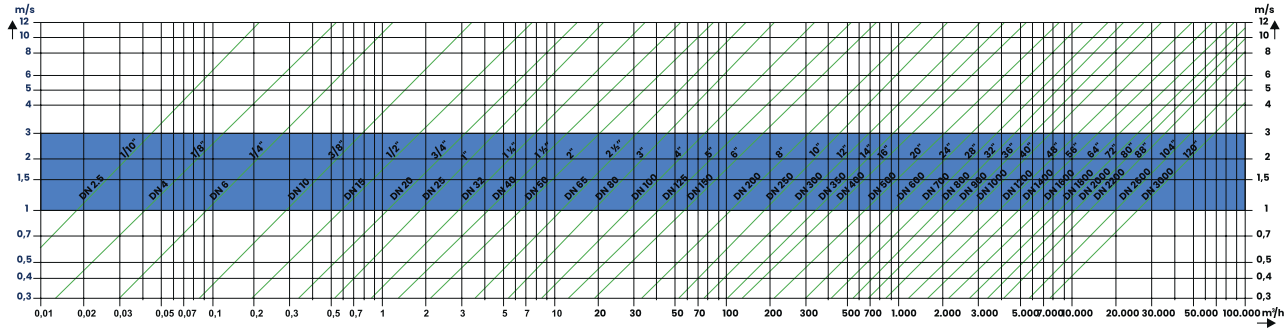

- 1- The appropriate product diameters can be selected based on the flow rate information.
- 2- The appropriate product diameters can be selected based on the velocity information.
- 3- The flow measurement range can be determined based on the diameter information.



DIAMETER / FLOW VALUES

DN (mm)	DIAMETER	MIN. FLOW (m3/h)	MAX. FLOW (m3/h)	SENSITIVE MEASUREMENT RANGE (m3/h)
DN 15	1/2"	0,18	8,5	0,6-1,8
DN 20	3/4"	0,35	15	1,2-3,2
DN 25	1"	0,6	22	1,8-4,8
DN 32	1 1/4"	0,85	35	2,8-8,0
DN 40	1 1/2"	1,3	55	4,2-15,0
DN 50	2"	2,2	85	6,8-22,0
DN 65	2 1/2"	3,6	150	13-32
DN 80	3"	5,5	210	18-48
DN 100	4"	8,5	320	28-48
DN 125	5"	13	550	42-130
DN 150	6"	18	750	58-180
DN 200	8"	32	1500	120-320
DN 250	10"	52	2020	180-480
DN 300	12"	78	3010	250-700



4- The most stable range for measurement should be considered as 1-3 m/s.



ANSI 15 - 300 Flange Dimensions

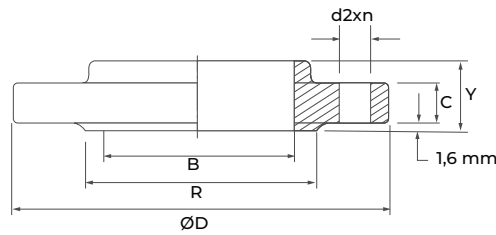
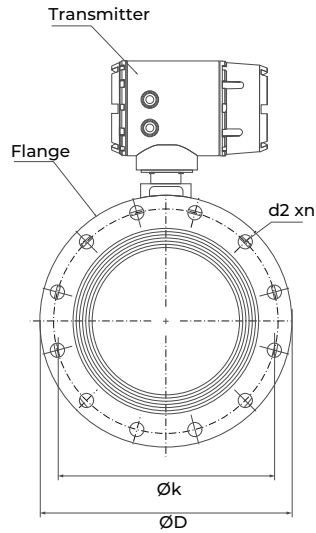

SLIP ON FLANGE CLASS 150
(ASME B 16.5 + MSS - SP 44 - 1996)
BS 3293

PIPE		D	C min	R	DRILLINGS			B min	X	Y	WEIGHT kg
DN	NPS				n	K	d ₂				
15	1/2"	89	11,2	34,9	4	60,3	15,8	22,4	30	16	0,8
20	3/4"	99	12,7	42,9	4	69,8	15,8	27,7	38	16	0,9
25	1"	108	14,3	50,8	4	79,4	15,8	34,5	49	17	1
32	1 1/4"	117	15,7	63,5	4	88,9	15,8	43,2	59	21	1,3
40	1 1/2"	127	17,5	73	4	98,4	15,8	49,5	65	22	1,5
50	2"	152	19,1	92,1	4	120,6	19	62	78	25	2,3
65	2 1/2"	178	22,3	104,8	4	139,7	19	74,7	90	29	3,7
80	3"	190	23,9	127	4	152,4	19	90,7	108	30	4,2
100	4"	229	23,9	157,2	8	190,5	19	116,1	135	33	5,9
125	5"	254	23,9	185,7	8	215,9	22,2	143,8	164	37	7
150	6"	279	25,4	215,9	8	241,3	22,2	170,7	192	40	8,5
200	8"	343	28,5	269,9	8	298,4	22,2	221,5	246	44	13,5
250	10"	406	30,2	323,8	12	362	25,4	276,4	305	49	19,5
300	12"	483	31,8	381	12	431,8	25,4	327,2	365	56	29

SLIP ON FLANGE CLASS 300
(ASME B 16.5 + MSS - SP 44 - 1996)
BS 3293

PIPE		D	C min	R	DRILLINGS			B min	X	Y	WEIGHT kg
DN	NPS				n	K	d ₂				
15	1/2"	95	14,2	34,9	4	66,7	15,8	22,4	38	22	1,2
20	3/4"	117	15,7	42,9	4	82,6	19	27,7	48	25	1,3
25	1"	124	17,5	50,8	4	88,9	19	34,5	54	27	1,4
32	1 1/4"	133	19	63,5	4	98,4	19	43,2	64	27	1,8
40	1 1/2"	156	20,6	73	4	114,3	22,2	49,5	70	30	2,5
50	2"	165	22,4	92,1	8	127	19	62	84	33	3
65	2 1/2"	190	25,4	104,8	8	149,2	22,2	74,7	100	38	4,5
80	3"	210	28,4	127	8	168,3	22,2	90,7	117	43	6
100	4"	254	31,8	157,2	8	200	22,2	116,1	146	48	10,1
125	5"	279	35	185,7	8	235	22,2	143,8	178	51	12,5
150	6"	318	36,6	215,9	12	269,9	22,2	170,7	206	52	17,5
200	8"	381	41,1	269,9	12	330,2	25,4	221,5	260	62	26
250	10"	444	47,8	323,8	16	387,4	28,5	276,4	320	66	28
300	12"	521	38,1	381	16	450,8	31,8	327,2	375	73	52

Flowmeter Connection Dimensions

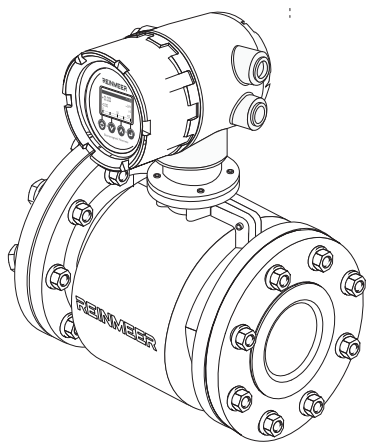

DN (mm)	Pressure Class	FLANGE							Perimeter hole Number (d)	Bolt Dia.
		L	B	C	S	T	D			
15	40 Bar	150	95	65	100	140	14	4	M12	
20		150	105	75	100	140	14	4	M12	
25		200	115	85	100	140	14	4	M12	
32		200	140	100	110	180	18	4	M16	
40		200	150	110	110	180	18	4	M16	
50		200	165	125	110	180	18	4	M16	
65		200	185	145	110	210	18	8	M16	
80	16 Bar	200	200	160	110	210	18	8	M16	
100		250	220	180	150	240	18	8	M16	
125		250	250	210	150	270	18	8	M16	
150	10 Bar	300	285	240	180	300	22	8	M20	
200		350	340	295	240	360	22	8	M20	
250		400	395	350	290	430	22	12	M20	
300		500	445	400	310	480	22	12	M20	

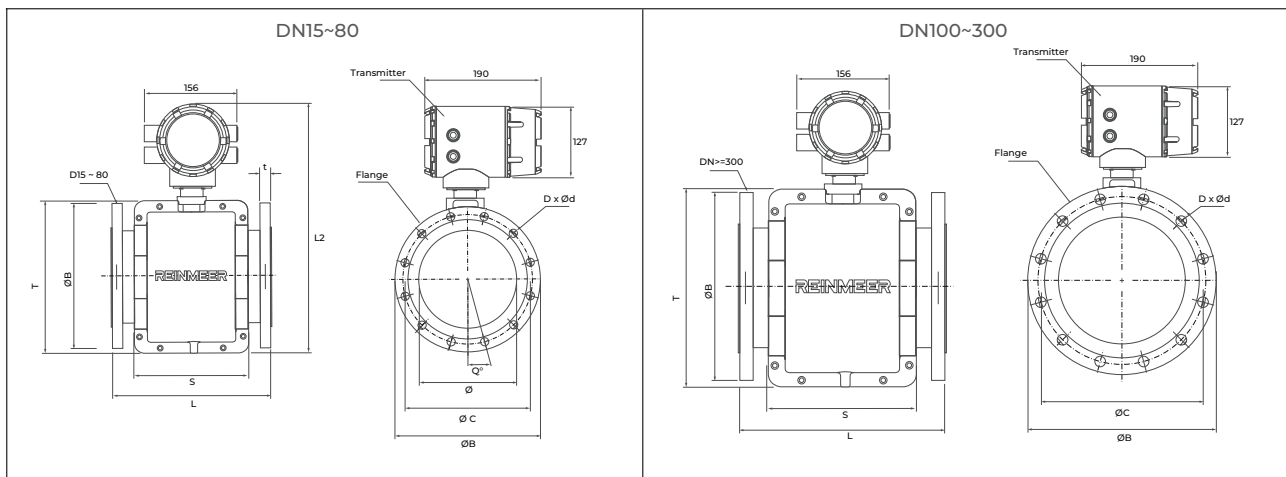
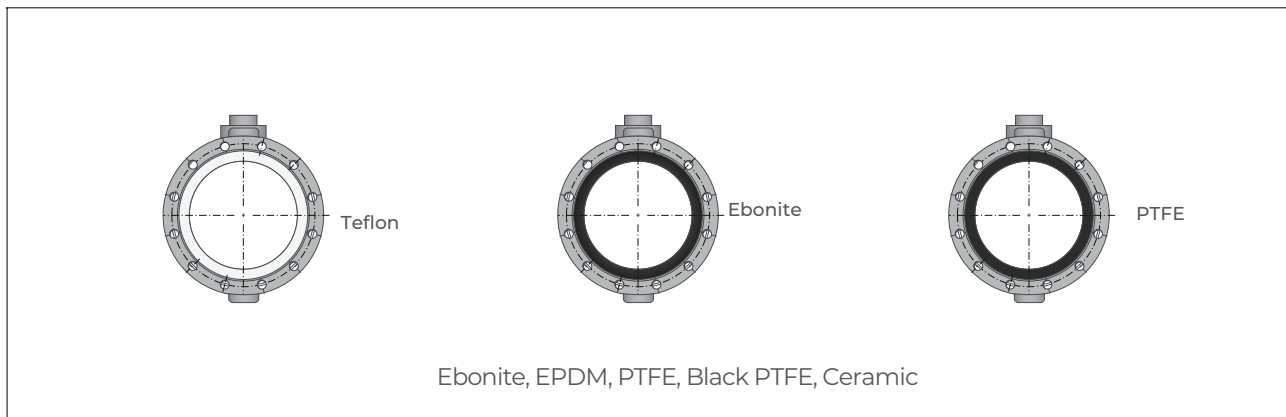

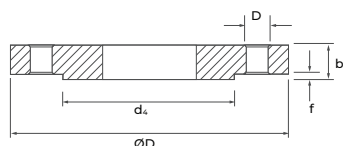
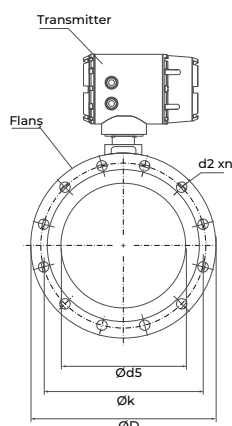

Flange Weld On Pipe PN6
TS-EN 1092-1 /
TYPE 01/ DIN 2573

PIPE DN	FLANGE					RAISED FACE		DRILLINGS			WEIGHT	
	d _s	D	b		k	d ₄	f	n	screw	d ₂	EN 1092 - 1	DIN2501
			EN 1092-1	DIN2501							kg/ad - kg/pcs	kg/ad - kg/pcs
15	22	80	12	12	55	40	2	4	M10	11	0,35	0,35
20	27,5	90	14	14	65	50	2	4	M10	11	0,53	0,53
25	34,5	100	14	14	75	60	2	4	M10	11	0,65	0,65
32	43,5	120	16	14	90	70	2	4	M12	14	1,05	0,91
40	49,5	130	16	14	100	80	3	4	M12	14	1,20	1,00
50	61,5	140	16	14	110	90	3	4	M12	14	1,30	1,10
65	77,5	160	16	14	130	110	3	4	M12	14	1,60	1,40
80	90,5	190	18	16	150	128	3	4	M16	18	2,60	2,30
100	116	210	18	16	170	148	3	4	M16	18	2,90	2,50
125	141,5	240	20	18	200	178	3	8	M16	18	3,90	3,50
150	170,5	265	20	18	225	202	3	8	M16	18	4,30	3,80
200	221,5	320	22	20	280	258	3	8	M16	18	6,30	5,60
250	276,5	375	24	22	335	312	3	12	M16	18	8,20	7,50
300	327,5	440	24	22	395	365	4	12	M20	22	10,60	9,60

Flange Weld On Pipe PN10
TS-EN 1092-1 /
TYPE 01 / DIN 2576

PIPE DN	FLANGE					RAISED FACE		DRILLINGS			WEIGHT	
	d _s	D	b		k	d ₄	f	n	screw	d ₂	EN 1092 - 1	DIN2501
			EN 1092-1	DIN2501							kg/ad - kg/pcs	kg/ad - kg/pcs
15	22	95	14	14	65	45	2	4	M12	14	0,59	0,59
20	27,5	105	16	16	75	58	2	4	M12	14	0,85	0,85
25	34,5	115	16	16	85	68	2	4	M12	14	1,01	1,01
32	43,5	140	18	16	100	78	2	4	M16	18	1,70	1,50
40	49,5	150	18	16	110	88	3	4	M16	18	1,80	1,60
50	61,5	165	20	18	125	102	3	4	M16	18	2,50	2,20
65	77,5	185	20	18	145	122	3	(1092)8/4 (DIN)	M16	18	3,00	2,70
80	90,5	200	20	20	160	138	3	8	M16	18	3,30	3,30
100	116	220	22	20	180	158	3	8	M16	18	4,00	3,60
125	141,5	250	22	22	210	188	3	8	M16	18	5,00	5,00
150	170,5	285	24	22	240	212	3	8	M20	22	6,50	6,00
200	221,5	340	24	24	295	268	3	8	M20	22	8,50	8,50
250	276,5	395	26	26	350	320	3	12	M20	22	11,00	11,00
300	327,5	450	26	26	400	370	4	12	M20	22	12,30	12,30

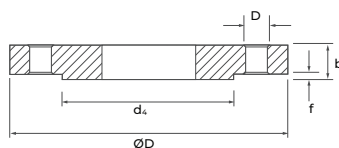
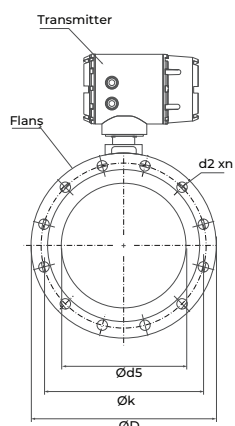

Flange Weld On Pipe PN16
TS-EN 1092-1 /
TYPE 01 / DIN 2576

PIPE	FLANGE					RAISED FACE		DRILLINGS			WEIGHT		
	DN	d _s	D	b		k	d ₄	f	n	screw	d ₂	EN 1092 - 1 kg/ad - kg/pcs	DIN2501 kg/ad - kg/pcs
				EN 1092-1	DIN2501								
15	22	95	14	14	65	45	2	4	M12	14	0,60	0,60	
20	27,5	105	16	16	75	58	2	4	M12	14	0,90	0,90	
25	34,5	115	16	16	85	68	2	4	M12	14	1,00	1,00	
32	43,5	140	18	16	100	78	2	4	M16	18	1,70	1,50	
40	49,5	150	18	16	110	88	3	4	M16	18	1,80	1,60	
50	61,5	165	20	18	125	102	3	4	M16	18	2,50	2,20	
65	77,5	185	20	18	145	122	3	(1092)8/4 (DIN)	M16	18	2,90	2,50	
80	90,5	200	20	20	160	138	3	8	M16	18	3,30	3,30	
100	116	220	22	20	180	158	3	8	M16	18	4,00	3,60	
125	141,5	250	22	22	210	188	3	8	M16	18	5,00	5,00	
150	170,5	285	24	22	240	212	3	8	M20	22	6,50	6,00	
200	221,5	340	26	24	295	268	3	12	M24	22	9,00	8,30	
250	276,5	405	29	26	355	320	3	12	M24	26	13,3	11,80	
300	327,5	460	32	28	410	378	4	12	M24	26	17,50	15,10	

Flange Weld On Pipe PN25
TS-EN 1092-1 /
TYPE 01 / DIN 2576

PIPE	FLANGE					RAISED FACE		DRILLINGS			WEIGHT		
	DN	d _s	D	b		k	d ₄	f	n	screw	d ₂	EN 1092 - 1 kg/ad - kg/pcs	DIN2501 kg/ad - kg/pcs
				EN 1092-1	DIN2501								
15	22	95	14	14	65	45	2	4	M12	14	0,59	0,69	
20	27,5	105	16	16	75	58	2	4	M12	14	0,85	0,97	
25	34,5	115	16	16	85	68	2	4	M12	14	1,01	1,15	
32	43,5	140	18	18	100	78	2	4	M16	18	1,68	1,68	
40	49,5	150	18	18	110	88	3	4	M16	18	1,80	1,80	
50	61,5	165	20	20	125	102	3	4	M16	18	2,50	2,50	
65	77,5	185	22	22	145	122	3	8	M16	18	3,20	3,20	
80	90,5	200	24	24	160	138	3	8	M16	18	4,00	4,00	
100	116	235	26	24	190	162	3	8	M20	22	5,60	5,20	
125	141,5	270	28	26	220	188	3	8	M24	26	7,60	7,00	
150	170,5	300	30	28	250	218	3	8	M24	26	9,60	8,90	
200	221,5	360	32	30	310	278	3	12	M24	26	13,50	12,60	
250	276,5	425	35	32	370	335	3	12	M27	30	19,10	17,40	
300	327,5	485	38	34	430	395	4	16	M27	30	25,00	22,20	

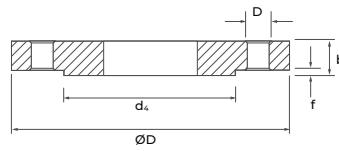
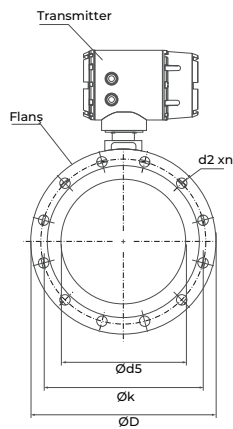

Flange Weld On Pipe PN40
TS-EN 1092-1 /
TYPE 01 / DIN 2576

PIPE DN	FLANGE					RAISED FACE		DRILLINGS			WEIGHT	
	d _s	D	b		k	d ₄	f	n	screw	d ₂	EN 1092 - 1	DIN2501
			EN 1092-1	DIN2501							kg/ad - kg/pcs	kg/ad - kg/pcs
15	22	95	14	14	65	45	2	4	M12	14	0,59	0,69
20	27,5	105	16	16	75	58	2	4	M12	14	0,85	0,97
25	34,5	115	16	16	85	68	2	4	M12	14	1,01	1,15
32	43,5	140	18	18	100	78	2	4	M16	18	1,67	1,67
40	49,5	150	18	18	110	88	3	4	M16	18	1,80	1,80
50	61,5	165	20	20	125	102	3	4	M16	18	2,40	2,40
65	77,5	185	22	22	145	122	3	8	M16	18	3,20	3,20
80	90,5	200	24	24	160	138	3	8	M16	18	4,00	4,00
100	116	235	26	24	190	162	3	8	M20	22	5,60	5,10
125	141,5	270	28	26	220	188	3	8	M24	26	7,60	7,00
150	170,5	300	30	28	250	218	3	8	M24	26	9,60	8,90
200	221,5	375	36	34	320	285	3	12	M27	30	17,00	16,00
250	276,5	450	42	38	385	345	3	12	M30	33	28,00	25,20
300	327,5	515	52	42	450	410	4	16	M30	33	43,10	34,50

Flange Weld On Pipe PN64
TS-EN 1092-1 /
TYPE 01 / DIN 2576

PIPE DN	FLANGE					RAISED FACE		DRILLINGS			WEIGHT	
	d _s	D	b		k	d ₄	f	n	screw	d ₂	EN 1092 - 1	DIN2501
			EN 1092-1	DIN2501							kg/ad - kg/pcs	kg/ad - kg/pcs
15	22	105	20	20	75	45	2	4	M12	14	1,10	1,10
20	27,5	130	22	22	90	58	2	4	M16	18	1,86	1,86
25	34,5	140	24	24	100	68	2	4	M16	18	2,37	2,37
32	43,1	155	24	24	110	78	3	4	M20	22	2,70	2,70
40	49	170	26	26	125	88	3	4	M20	22	3,60	3,60
50	61,1	180	26	26	135	102	3	4	M20	22	3,90	3,90
65	71,1	205	26	26	160	122	3	8	M20	22	4,70	4,70
80	90,3	215	30	28	170	138	3	8	M20	22	5,90	5,50
100	115,9	250	32	30	200	162	3	8	M24	26	8,00	7,50
125	141,6	295	34	34	240	188	3	8	M27	30	11,70	11,70
150	170,5	345	36	36	280	218	3	8	M30	33	16,90	16,90
200	221,5	415	48	42	345	285	3	12	M33	36	30,50	26,50
250	276,2	470	55	46	400	345	3	12	M33	36	42,20	35,00
300	327,6	530	65	52	460	410	4	16	M33	36	59,00	46,80

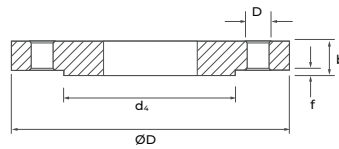
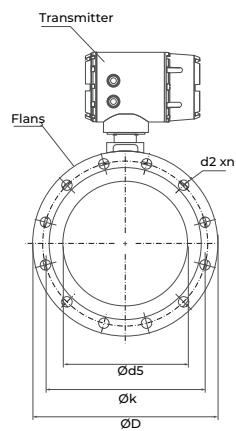

Flange Weld On Pipe PN100
TS-EN 1092-1 /
TYPE 01 / DIN 2576

PIPE	FLANGE					RAISED FACE		DRILLINGS			WEIGHT		
	DN	d _s	D	b		k	d ₄	f	n	screw	d ₂	EN 1092 - 1	DIN2501
				EN 1092-1	DIN2501							kg/ad - kg/pcs	kg/ad - kg/pcs
15	22	105	20	20	75	45	2	4	M12	14	1,10	1,10	
20	27,6	130	22	22	90	58	2	4	M16	18	1,86	1,86	
25	34,4	140	24	24	100	68	2	4	M16	18	2,37	2,37	
32	43,1	155	24	24	110	78	3	4	M20	22	2,70	2,70	
40	49	170	26	26	125	88	3	4	M20	22	3,58	3,58	
50	61,1	195	28	28	145	102	3	4	M24	26	5,00	5,00	
65	77,1	220	30	30	170	122	3	8	M24	26	6,34	6,34	
80	90,3	230	34	32	180	138	3	8	M24	26	7,73	7,24	
100	115,9	265	36	36	210	162	3	8	M27	30	10,33	10,30	
125	141,6	315	42	40	250	188	3	8	M30	33	17,24	16,40	
150	170,5	355	48	44	290	218	3	12	M30	33	23,63	21,60	
200	221,5	430	60	52	360	285	3	12	M33	36	42,90	37,00	
250	276,2	505	72	60	430	345	3	12	M36	39	69,12	57,20	
300	327,6	585	84	68	500	410	4	16	M39	42	103,52	83,10	

CONDITIONS OF USE



In order to make precise and reliable measurements in Reinmeer Series electromagnetic flowmeters, the following conditions must be met;

1. The tested fluid must have a conductivity of 5 μ S or higher
2. The pipeline must have a fully filled flow
3. The components within the fluid must be homogenously mixed
4. If the fluid induces magnetic fields, the magnetic field of the device will change, and the device will need to be recalibrated.
5. Installation methods complying with laminar flow regulations must be applied.
6. For plastic and non-conductive pipes, grounding rings and grounding connections must be included during installation.
7. Regardless of the pipe type, grounding connections must be made.



The dimensions of the ground loop of the flange sensor are between 15 and 300 mm.

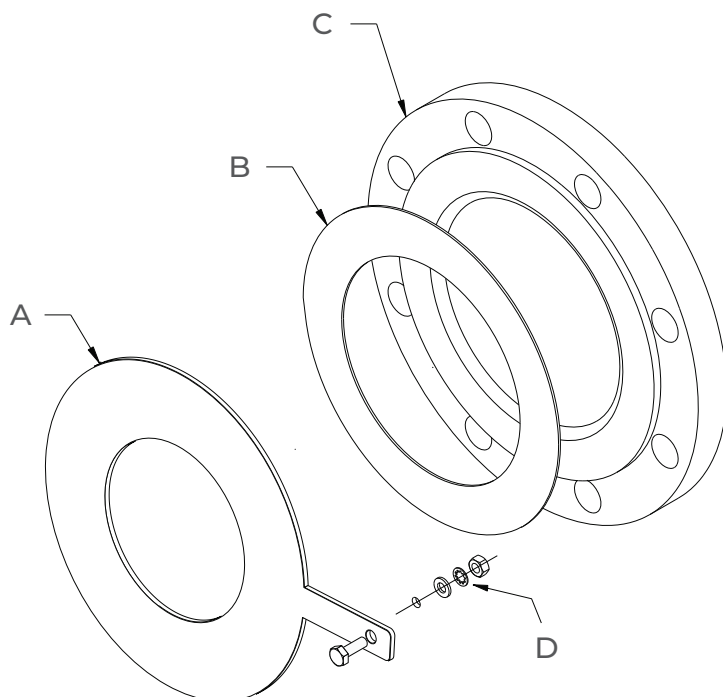

- A. Grounding ring
- B. Customer-supplied gasket
- C. Measuring flange
- D. Screw

DN	Thickness of grounding ring
15	2
20	2
25	2
32	2
40	2
50	2
65	2
80	2
100	2
125	2
150	2
200	2
250	2
300	2

MOUNTING METHODS

<p>Mounting Method</p>	<p>90° Elbow</p>
<p>Expansion Tube</p>	<p>Various Valves</p>
<p>Valve in Fully Open Position</p>	<p>Installation in Open-End Pipelines</p>
<p>Installation in Curved Pipes</p>	<p>Inlet-Outlet Installation Application</p>
<p>T-shaped Pipe</p>	<p>Inlet-Outlet Mounting Application</p>

Installation in Partially Filled Installations

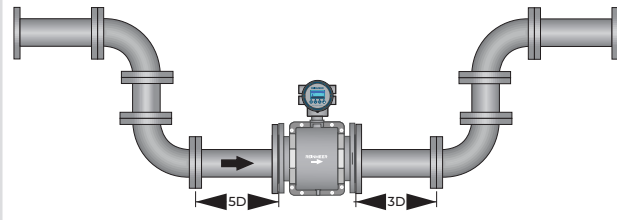
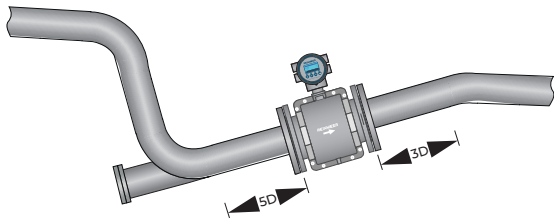

Installation in Pumping Systems

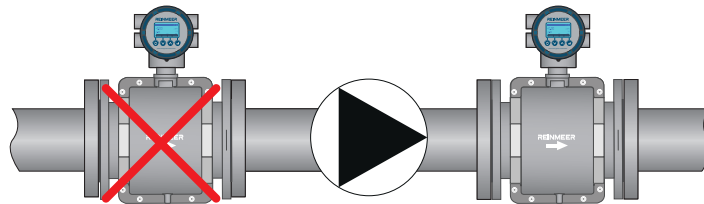

Grounding Line

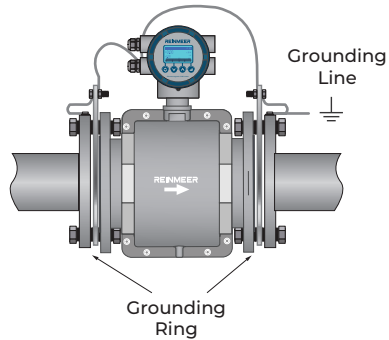

It is mandatory to use a grounding ring in plastic lines and in lines with pipe insulation.

Grounding Connection

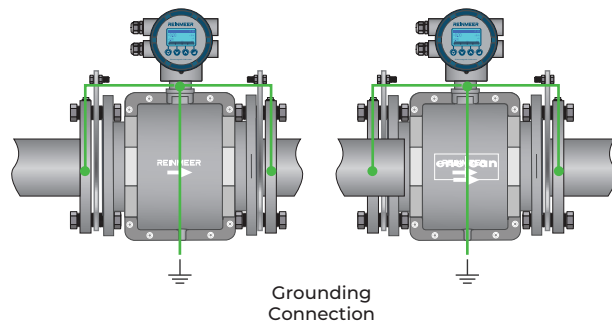

Avoid Magnetic Fields Avoid Vibration

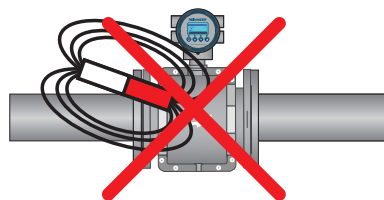

Avoid Vibration

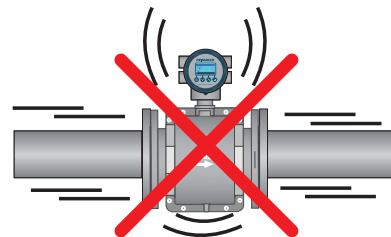

DN100 (4'') / EN - PL - D16C - GE - MT - O23 - R3 - SI20 - DC - M2R - GSM
1 2 3 4 5 6 7 8 9 10 11

1 Internal Lining Material

Ebonite	<input checked="" type="checkbox"/>	EN
EPDM (Soft Rubber)	<input type="checkbox"/>	SR
PTFE	<input type="checkbox"/>	PT
Black PTFE	<input type="checkbox"/>	BPT
Ceramic	<input type="checkbox"/>	CR

2 Electrode Material

316 Stainless Steel	<input type="checkbox"/>	SS
Hastelloy C22	<input type="checkbox"/>	HC
Platinum Rhodium	<input checked="" type="checkbox"/>	PL
Tantalum	<input type="checkbox"/>	TA
Titanium	<input type="checkbox"/>	Ti

3 Process Connection

PN40, EN1092-1 Flange, St37-2	<input type="checkbox"/>	D40C
PN25, EN1092-1 Flange, St37-2	<input type="checkbox"/>	D25C
PN16, EN1092-1 Flange, St37-2	<input checked="" type="checkbox"/>	D16C
PN10, EN1092-1 Flange, St37-2	<input type="checkbox"/>	D10C
PN6, EN1092-1 Flange, St37-2	<input type="checkbox"/>	D6C
Class 300 RF ANSI Flange, St37-2	<input type="checkbox"/>	A30C
Class 150 RF ANSI Flange, St37-2	<input type="checkbox"/>	A15C
PN40, EN1092-1 Flange, SS 316L	<input type="checkbox"/>	D40S
PN25, EN1092-1 Flange, SS 316L	<input type="checkbox"/>	D25S
PN16, EN1092-1 Flange, SS 316L	<input type="checkbox"/>	D16S
PN10, EN1092-1 Flange, SS 316L	<input type="checkbox"/>	D10S
PN6 EN1092-1 Flange, SS 316L	<input type="checkbox"/>	D6S
Class 300 RF ANSI Flange, SS 316L	<input type="checkbox"/>	A30S
Class 150 RF ANSI Flange, SS 316L	<input type="checkbox"/>	A15S
Tri-Clamp Connection, SS 316L	<input type="checkbox"/>	TRIS
DIN 11851 Hygienic Connection, 1.4404 (316L)	<input type="checkbox"/>	SANS

4 Grounding

Standard 3. Electrode	<input type="checkbox"/>	XX
Grounding Ring	<input checked="" type="checkbox"/>	GE
316L Grounding Ring	<input type="checkbox"/>	GESS
Hastelloy C22	<input type="checkbox"/>	GEHC

6 Calibration

Dry Calibration, standard	<input type="checkbox"/>	000
0,5%, 3-point factory calibrated	<input type="checkbox"/>	053
0,5%, 5-point factory calibrated	<input type="checkbox"/>	055
0,2%, 3-point T17025 accredited calibration	<input checked="" type="checkbox"/>	023
0,2%, 5-point T17025 accredited calibration	<input type="checkbox"/>	025

7 Transmitter Type, Protection Class

Compact, IP67	<input type="checkbox"/>	C1
Compact, IP67 (Rectangle)	<input type="checkbox"/>	C2
Remote, IP67 (Rectangle)	<input checked="" type="checkbox"/>	R1

8 Cable Length (for Separate Type)

None	<input type="checkbox"/>	XX
5-meter signal cable	<input type="checkbox"/>	5
10-meter signal cable	<input type="checkbox"/>	10
20-meter signal cable	<input type="checkbox"/>	20
30-meter signal cable	<input type="checkbox"/>	30
40-meter signal cable	<input type="checkbox"/>	40
Additional 1 meter signal cable	<input type="checkbox"/>	XX
LP-20 7 Pin S-0/P-E Nut-Type IP68 Plug and Play 5 meter signal cable	<input type="checkbox"/>	SI5
LP-20 7 Pin S-D/P-E Nut-Type IP68 Plug and Play 10 meter signal cable	<input type="checkbox"/>	SI10
LP-20 7 Pin S-0/P-E Nut-Type IP68 Plug and Play 20 meter signal cable	<input checked="" type="checkbox"/>	SI20
LP-20 7 Pin S-0/P-E Nut-Type IP68 Plug and Play 30-meter signal cable	<input type="checkbox"/>	SI30
LP-20 7 Pin S-0/P-E Nut-Type IP68 Plug and Play 40 meter signal cable	<input type="checkbox"/>	SI40

9 Power Supply Voltage

Battery Supply	<input type="checkbox"/>	BT
80 ... 230 VAC (48 ... 60 Hz)	<input type="checkbox"/>	AC
8 ... 36VDC	<input checked="" type="checkbox"/>	DC

10 Output Signal

4...20 mA, RS485 MODBUS, pulse, alarm, status	<input checked="" type="checkbox"/>	M2R
4...20 mA, HART, pulse, alarm, status	<input type="checkbox"/>	M2H
PROFIBUS (Only with rectangular transmitter)	<input type="checkbox"/>	M2P

11 Option 1

No straight pipe required	<input type="checkbox"/>	MXD
---------------------------	--------------------------	-----

Option 2

Stainless Steel Body	<input type="checkbox"/>	SSB
Stainless Steel Body + Stainless Steel Enclosure	<input type="checkbox"/>	SSBF
Stainless Steel Flange	<input type="checkbox"/>	SSPF

Option 3

Digital GSM Datalogger (Only with rectangular transmitter)	<input checked="" type="checkbox"/>	GSM
--	-------------------------------------	-----

Contact us

Adress :

Reinmeer Factory Address
Eutiner Str.12,22143
Hamburg, Germany
reinmeer@reinmeer.com