

REINMEER

www.reinmeer.com



Electromagnetic Batching, Filling & Dosing Flowmeter Instruction Manual

MODEL: RM-REMFIL

**ELECTROMAGNETIC
FLOWMETERS**

INSTRUCTION MANUAL

FOR Electromagnetic batching, dosing and filling flowmeters

Remfil 15 – 1DO1AO – 8	Remfil 25 – 1DO1AO – 8
Remfil 15 – 2DO – 8	Remfil 25 – 2DO – 8
Remfil 15 – 1DO – 8	Remfil 25 – 1DO – 8
Remfil 15 – 1DO - 5	Remfil 25 – 1DO – 5



The process medium may be hot or otherwise hazardous.

- Precautions when removing the sensor from the process line:
- Make positively sure that the process line is not under pressure. Open a vent valve to the atmosphere.
- Loosen the clamp cautiously, be prepared to tighten again.
- Be out of the way of any possible splash and ensure the possibility of escape.
- Use shields and protective clothing adequate for the process medium.
- Do not rely on avoidance of contact with the process medium.
- After removal of the sensor, it may be necessary to mount a blind cover for security reasons.

Storage conditions:



- ① Store the device in a dry and dust-free location.
- ① Avoid lasting direct exposure to the sun.
- ① Store the device in its original packaging.
- ① Storage temperature: -50 ...+70°C / -58...+158°F

General Information:







- The IP68 label express the ingress protection of the device.
- The equipment box contains a Reinmeer Electromagnetic Flowmeter, the cable connector and the installation connections.
- This product manual is delivered to the end user with a product.
- This product may be used to measure and control the filling or dosing processes of liquid mediums with electrical conductivity above 5µs/cm.
- If the equipment is used in a manner not specified by this instruction manual, the protection provided by the equipment may be impaired.

1 Warning and Symbols









1.1 General warning and Symbols

Symbol	Explanation
	<p>Danger</p> <p>This warning refers to the immediate danger of burns caused by electricity.</p>
	<p>Danger</p> <p>This warning refers to the immediate danger of burns caused by heat or hot surfaces.</p>
	<p>Danger</p> <p>These warnings must be observed without fail. Even partial disregard of this warning can lead to serious health problems and even death. There is also the risk of seriously damaging the device or parts of the operator's plant.</p>

1.2 Electrical Symbols

Symbol	Explanation
	<p>Direct current</p> <p>A terminal to which DC voltage is applied or through which direct current flows.</p>
	<p>Alternating current</p> <p>A terminal to which alternating voltage is applied or through which alternating current flows.</p>
	<p>Direct current and alternating current</p> <p>A terminal to which alternating voltage or DC voltage is applied.</p> <p>A terminal through which alternating current or direct current flows.</p>
	<p>Ground connection</p> <p>A grounded terminal which, as far as the operator is concerned, is grounded via a grounding system.</p>
	<p>Protective ground connection</p> <p>A terminal which must be connected to ground prior to establishing any other connections.</p>
	<p>Equipotential connection</p> <p>A connection that has to be connected to the plant grounding system: This may be a potential equalization line or a star grounding system depending on national or company codes of practice.</p>

1.3 Informative Symbols

Symbol	Explanation
	Permitted Indicates procedures, processes or actions that are permitted.
	Preferred Indicates procedures, processes or actions that are preferred.
	Forbidden Indicates procedures, processes or actions that are forbidden.
	Avoid Mechanical Vibrations Mechanical vibrations can cause damage or inaccuracy in the measurement
	Avoid Magnetic Field Magnetic field can lead to inaccuracy in the measurement.
	Tip Indicates additional information.
	Visual inspection
	HMI Unit page address

2. Introduction

2.1 Measuring principal

Following Faraday's law of magnetic induction, a voltage is induced in a conductor moving through a magnetic field. Figure 2-1 shows the faraday's law:

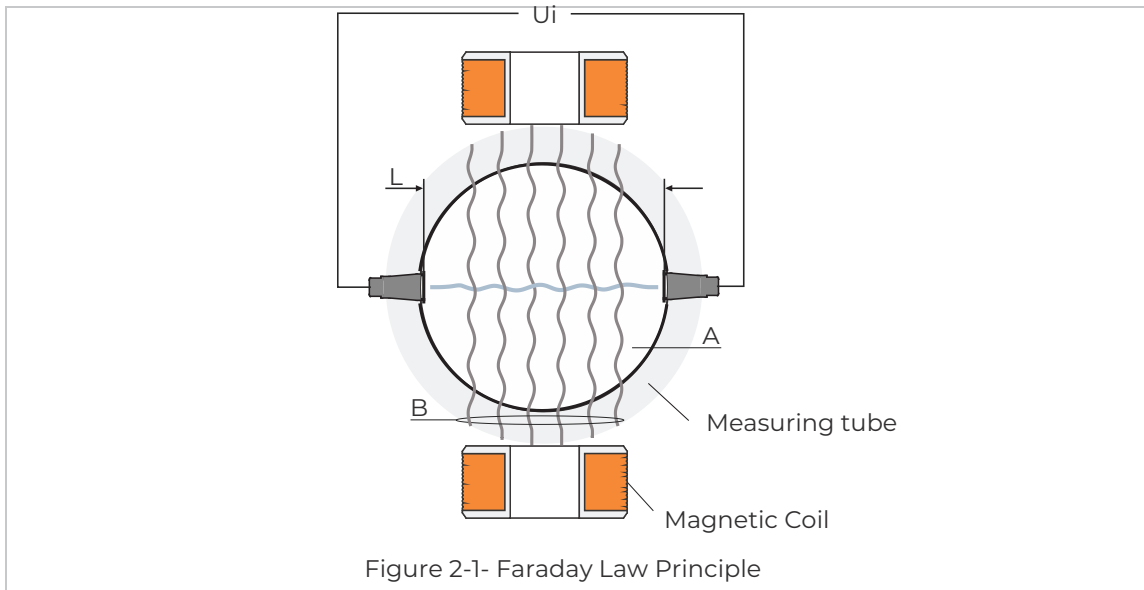

In the electromagnetic measuring principle, the flowing medium is the moving conductor. The voltage induced (U_i) is proportional to the flow velocity (v) and is supplied to the amplifier by means of two measuring electrodes. The flow volume (Q) is calculated via the pipe cross-section (A). The DC magnetic field is created through a switched direct current of alternating polarity.

Formulas for calculation:

- Induced voltage $U_i = B \cdot L \cdot v$
- Volume flow $Q = A \cdot v$

*In which "B" is the strength of magnetic field.

2.2 Reinmeer REMFIL Introduction

Remfil flowmeters generally consist of a transmitter unit which contains electronic cards that perform the calculations and prepare industrial input/outputs to communicate with the other devices and a sensor unit which the liquid medium flows in it. The device is available as a compact version and the transmitter and sensor form a mechanical unit.

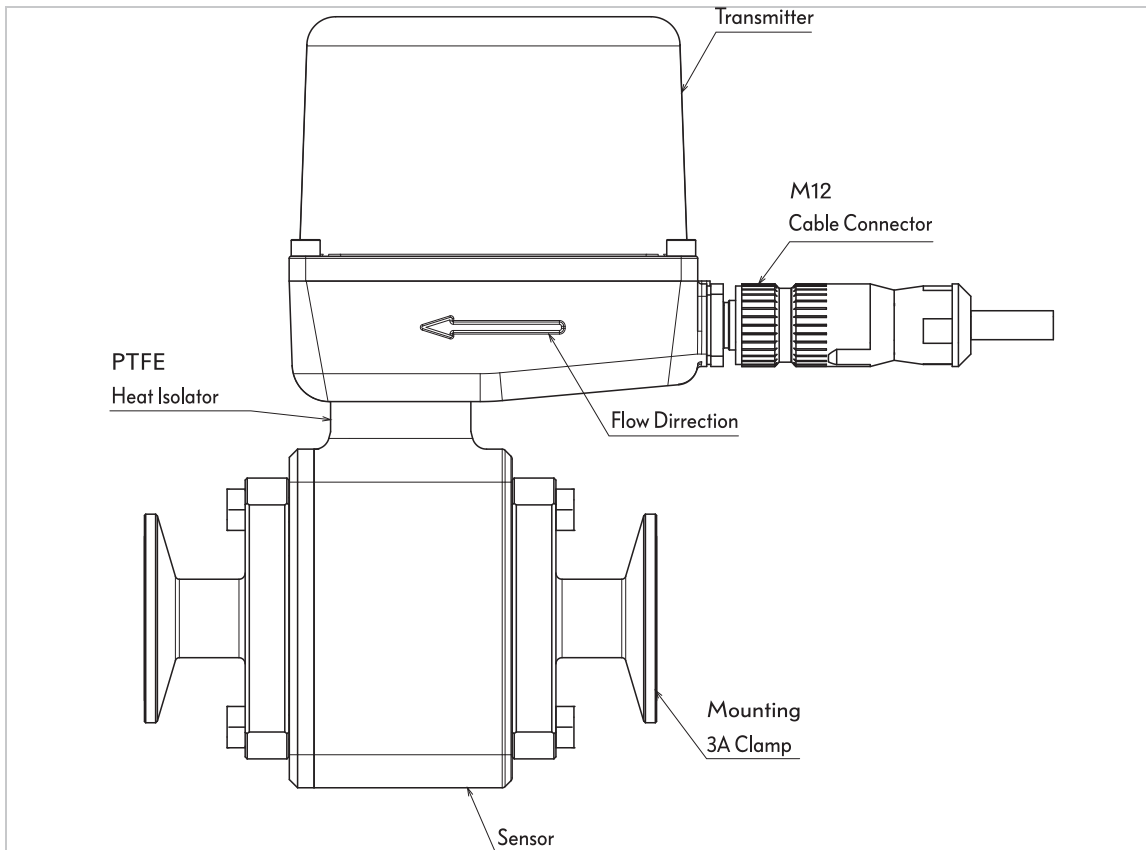
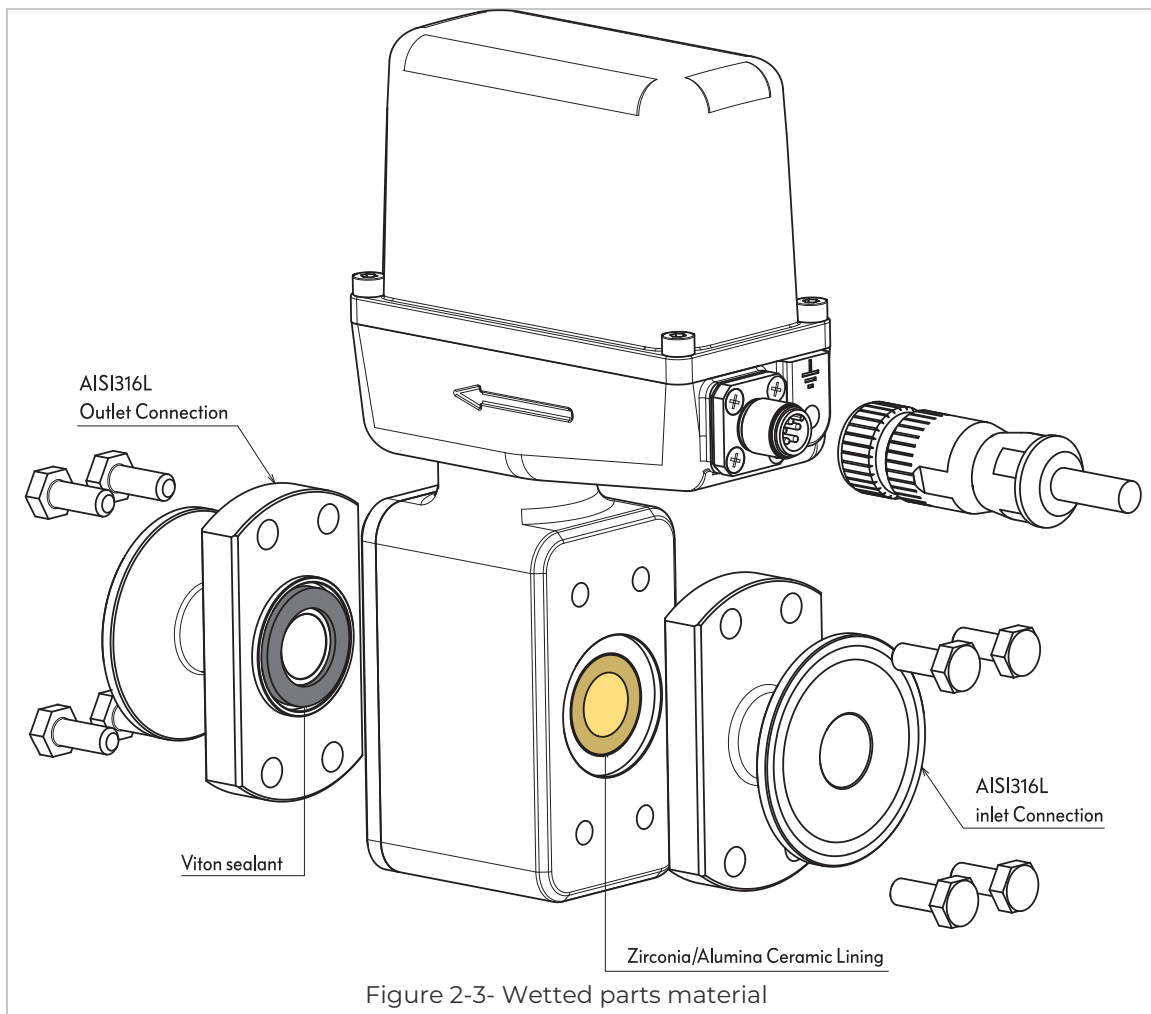

Figure 2-2- main parts and materials

<p><i>Transmitter:</i></p>	<p><i>Sensor:</i></p>
<p><i>Materials</i> <i>housing : AISI304</i> <i>housing seal : Viton</i> <i>Cable connection:</i> <i>5pin / 8pin M12 Connector</i></p>	<p><i>Materials</i> <i>sensor body : Stainless Steel AISI304</i> <i>lining : zirconium oxide ceramic</i> <i>electrodes : titanium/ hastelloy C276</i> <i>installation connections : AISI316L, AISI316ti</i></p>

2.3 Wetted parts material

Zirconia or Alumina Ceramic is used as the lining material of the Reinmeer Remfil flowmeters and the inlet/outlet connections are made out of 316L stainless steel (or AISI 316-Ti on request), a Viton gasket is also used as the sealant of the connection.



The direction of the arrow on the sensor nameplate helps you to install the sensor according to the flow direction

2.4 Dimensions and weight

Version A

Remfil15 xx Dimensions (mm)

Model	A	B	C	D	E	F	G	H	I	J	K	Ağırlık
Remfil 6	187	45	82	54	50	124	99	50.5	19	66	6	1.75 kg
Remfil 8	187	45	82	54	50	124	99	50.5	19	66	8	1.75 kg
Remfil 10	187	45	82	54	50	124	99	50.5	19	66	10	1.75 kg
Remfil 15	187	45	82	54	50	124	99	50.5	19	66	12	1.75 kg

REINMEER

Proje /Çizim _____

Revision _____

Not
1. All dimensions are shown.

Designer _____

Scale _____

1.12

No _____

Version B

Remfil25 xx Dimensions (mm)

Model	A	B	C	D	E	F	G	H	I	J	K	Ağırlık
Remfil 25	201	76	35	95	50	135	99	50.5	25.5	66	2	2.5 kg

REINMEER

Proje /Çizim _____

Revision _____

Not
1. All dimensions are shown.

Designer _____

Scale _____

1.12

No _____

2.5 Mechanical Properties

Fluid Temperature Range		-20°C~ 120°C
Ambient Temperature		-20°C~ 70°C
Maximum Fluid Pressure		16 Bar
Mounting Connection		3A Clamp
Protection		IP68
Material	Lining	Alumina/ Zirconia Ceramic
	Electrodes	Titanium, Hastelloy (On Request)
	Sensor mounting Connection	AISI 316L Stainless Steel
	Sensor Body	AISI 304 Stainless Steel
	Transmitter Body	AISI 304 Stainless Steel

2.6 Operating conditions

Temperature	
Process temperature	Dependent on ambient temperature. See chapter "Temperatures".
Cleaning temperature	SIP: Maximum 1 hour at 150°C / +302°F
	CIP: Maximum 1 hour at 140°C / +284°F
Shock	≤ 3 K/s
Ambient temperature	-40~+60°C / -40~+140°F
Storage temperature	-50~+70°C / -58~+158°F
Pressure	
Ambient	Atmospheric
Process pressure	up to 16 bar / 232 psi
Vacuum load	0 mbara / 0 psig
Chemical properties	
Electrical conductivity	≥ 5 μS/cm (≥ 20 μS/cm for demineralised water)
Recommended flow velocity	-12~+12 m/s / -39~+39 ft/s



This product may be used to measure and control the filling or dosing processes of liquid mediums with electrical conductivity above 5μS/cm. (above 20 μS/cm for demineralised water).

2.7 Transmitter Properties

Power	22~26 VDC, 500mA
Measurement Units	m ³ /h, m ³ /s, L/h, L/min, L/s, mL/min, mL/s with changeable dot points.
Cable Connector	5pin M12 Connector (8pin M12 connector on request)
Accuracy	0.3% Full Scale
Analog Outputs	Depending on the Model (see section 2.10)
Digital Outputs	Depending on the Model (see section 2.10)
Digital Inputs	Depending on the Model (see section 2.10)
Totalizer	2 independent totalizers with selectable units
Alarms	Empty Pipe, AQ Open Loop, Low Conductivity, etc.

2.7.1 Totalizer

Two independent totalizers with selectable units are available and one can access them through the Modbus network, (see section 8- Appendix A: RS485; Modbus RTU Parameters Address). The value of totalizers can also be seen in the HMI unit. (See section 5 “Setting using the HMI unit and Modbus network”).

2.8 Measurement accuracy

Reference conditions	Medium: water	
	Valve closing time variation: < 1 ms	
	Flow velocity: 1 m/s, flow conditions similar to EN 29104	
	Operating pressure: 1 bar / 14.5 psi	
Error limits at reference conditions for water, 600 µS/cm, 20°C / 68°F:		
Maximum measuring error	DN6~15:	
	±0.2% of measured value + 1 mm/s	
	DN25:	
	v ≤ 1 m/s: ±0.2% of measured value + 1 mm/s	
		v > 1 m/s: ±0.3% of measured value
Repeatability	DN25 Filling time	Standard deviation
	1.5~3 s	≤ 0.4%
	3~5 s	≤ 0.2%
	> 5 s	≤ 0.1%
	DN6~15 Filling time	Standard deviation
	1.5~3 s	≤ 0.3%
	3~5 s	≤ 0.15%
	> 5 s	≤ 0.08%

2.9 Measurement range

Size	Minimum Flow Rate	Maximum Flow Rate	Unit
DN (mm)			
6	30	400	L/h
8	50	700	L/h
10	70	1200	L/h
15	159	2000	L/h
25	441	14000	L/h

2.10 Models coding

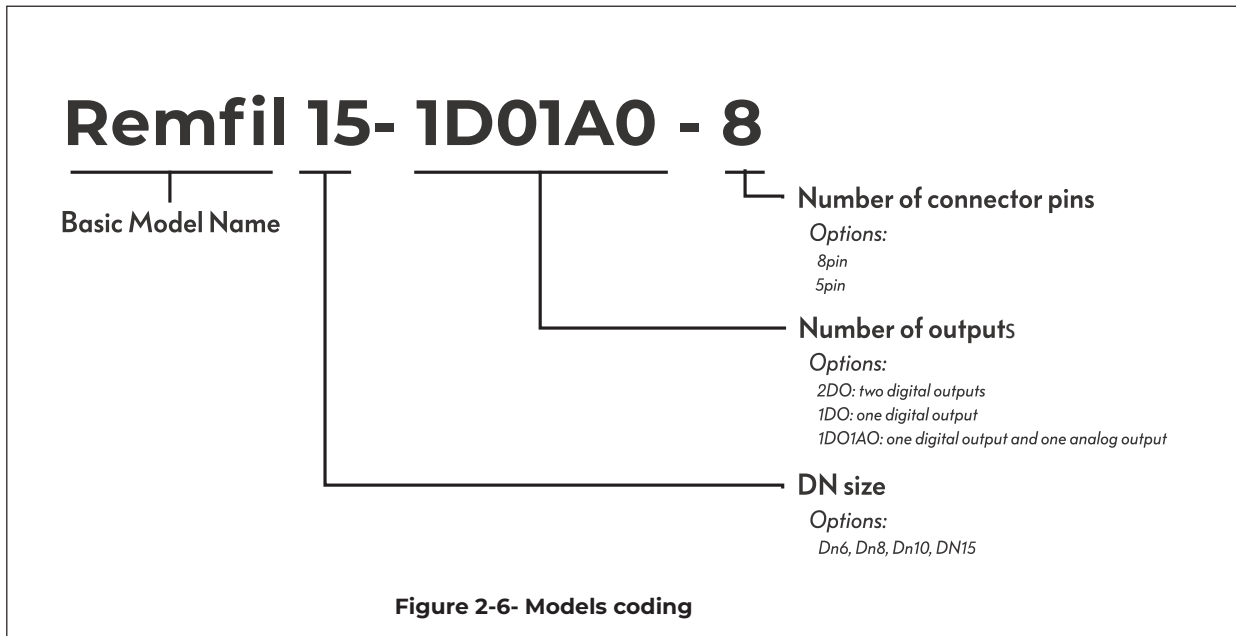

 All of the 8 pin models has one digital input which can be used in different hardware configuration (see section 5.2.2 Digital input setting).

2.11 Sensor Specifications Labels

Two specification labels are stuck on two sides of the transmitter body which show the general specifications and wiring of the device briefly. Figures below show these labels.

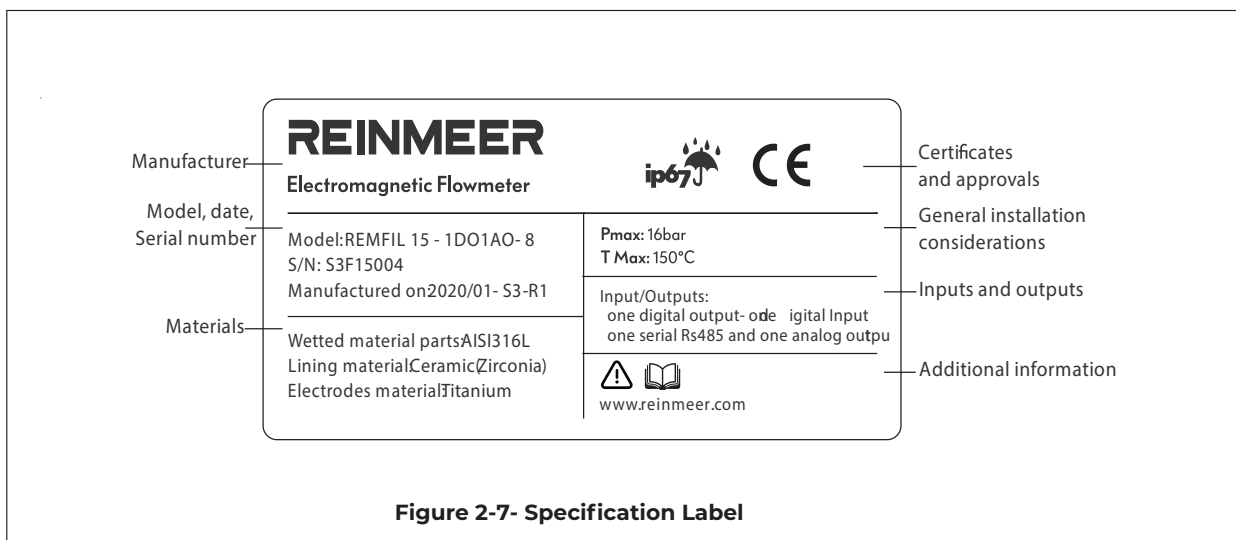

2.12 Wiring Labels

The wiring label which is attached to the opposite side of the transmitter body illustrates the function of each pin of the M12 connector.

(for more information see section 4 Input/Outputs and Wiring).

Pin	Name	Description
1	+	Power Input: Voltage = 22 - 26 VDC I _{max} =100mA
4	-	
8		
2	DO	Digital Output: F _{max} =4KHz, V=24V-DC, I _{max} =50mA
3	AO	Analog Output: I _{out} = Active 4-20mA, R _{max} = 900?
5	DI	Digital Input: V=24V I=5mA
6	A	RS485 Slave Modbus RTU:
7	B	38400bps, 8bit, NP, 1Stop

Figure 2-8- Wiring Label of the sensor
Model: Magfil xx - 1DO1AO-8

Pin	Name	Description
1	+	Power Input: Voltage = 22 - 26 VDC I _{max} =100mA
4	-	
8		
2	DO-1	Digital Outputs: F _{max} : 4KHz V=24V-DC I _{max} = 50mA
3	DO-2	
5	DI	Digital Input: V=24V I=5mA
6	A	RS485 Slave Modbus RTU:
7	B	38400bps, 8bit, NP, 1Stop

Figure 2-9- Wiring Label of the sensor
Model: Magfil xx - 2DO-8



Pin	Name	Description
1	+	Power Input: Voltage = 22 - 26 VDC I _{max} =100mA
4	-	
8		
2		Digital Output (with 10k pull down Resistor): F _{max} =4KHz V _{max} =30V I _{max} =50mA
3		
5	DI	Digital Input: V=24V I=5mA
6	A	RS485 Slave Modbus RTU:
7	B	38400bps, 8bit, NP, 1Stop

Figure 2-10- Wiring Label of the sensor
Model: Magfil xx - DO-8



Pin	Name	Description
1	+	Power Input: Voltage = 22 - 26 VDC I _{max} =100mA
4	-	
5		
2		Digital Output: F _{max} =4KHz V _{max} =30V I _{max} =50mA
3		
REINMEER		

Figure 2-11- Wiring Label of the sensor
Model: Magfil xx - 1DO-5

2.12 Wiring Labels

Three LEDs on the top of the sensor indicate the occurred fault, current status, and the power of the sensor respectively. Figure 2-12 illustrates the indicator LEDs and expresses their functionalities.

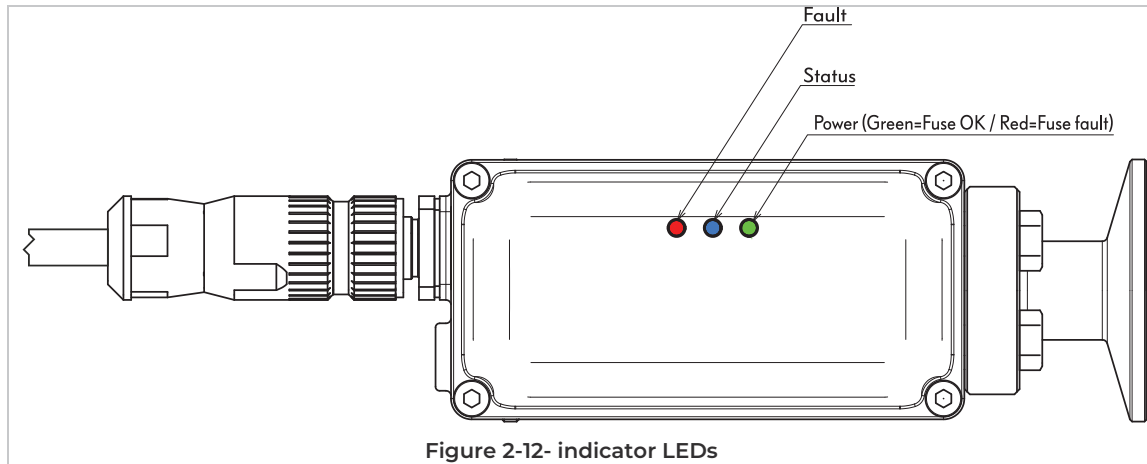

Figure 2-12- indicator LEDs

LED	Functionality
Fault	Following faults will turn this LED on: <ul style="list-style-type: none"> • Digital Output 1 Pulse overlap • Digital Output 2 Pulse overlap • Micro Controller HSE Error • Test Timer Timeout • Totalizer 1 Reset inhibited • Totalizer 2 Reset inhibited • Filling Error: Low Filling Flow Rate • Filling Error: High Filling Flow Rate • CPU Low Temperature • CPU High Temperature
Status	This LED show status of different events which are selectable using the sensor setting (see section 5.2.1). Selectable Events: <ul style="list-style-type: none"> • Flow Rate (0.5Hz) • Modbus Communication • Digital Output Status • Digital Input Status
Power	Green= Fuse OK/ Red= Fuse Fault

i If the power LED turned red it implies that the protective fuse of the sensor has been blown, in this case you must call Reinmeer local aftersales services.

i For more information about fault alarms and their solutions refer to section 8.9 Alarm List & Addresses(Bit)

3 Installation and mounting

3.1 Mounting components

The Reinmeer Remfil flowmeters can be mounted on the pipe line using a ferrule which is welded to the pipe line directly. Two silicone gaskets are used between the sensor outlet/inlet connection in each side of the sensor and a 3A clamp is used to fasten the connection to the ferrule. Figure 3-1 illustrates the different components used in mounting the sensor.

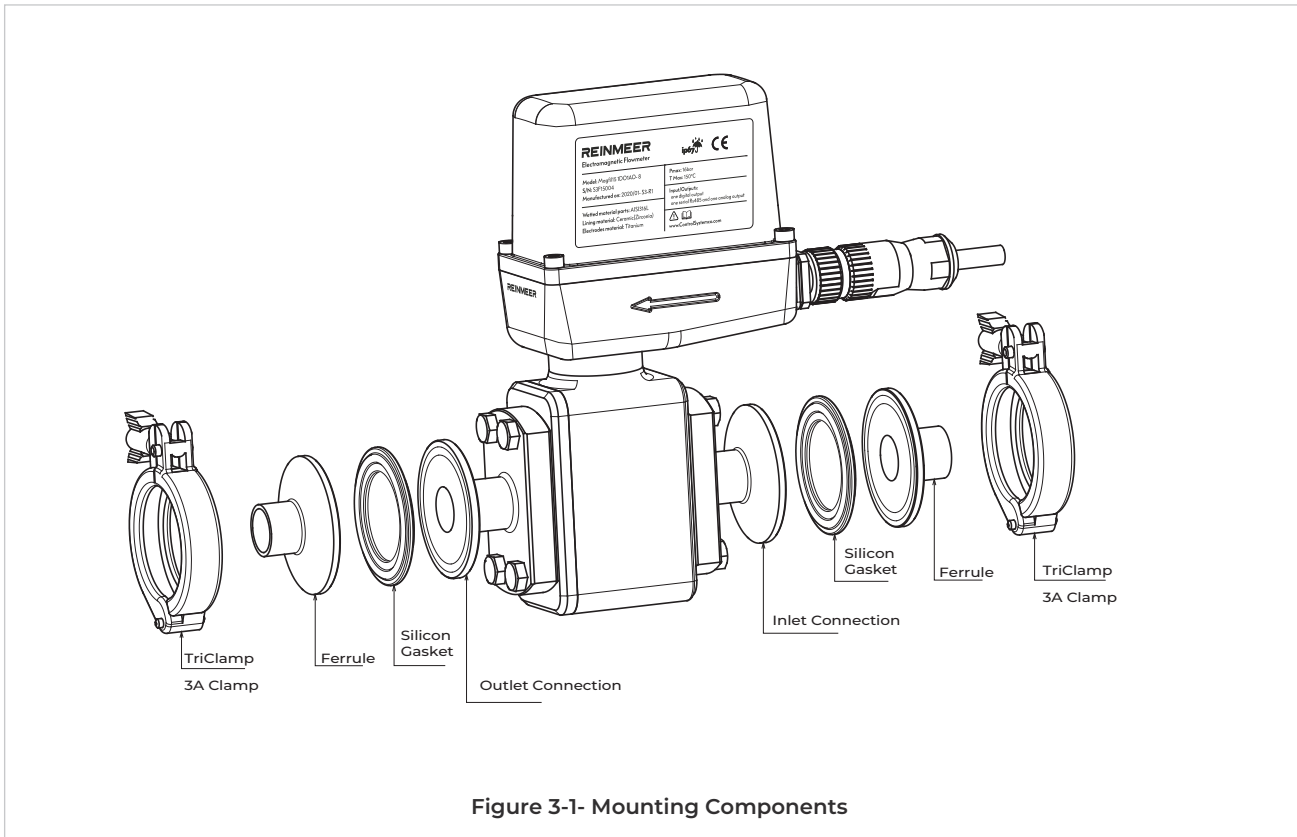

3.2 Mounting general consideration

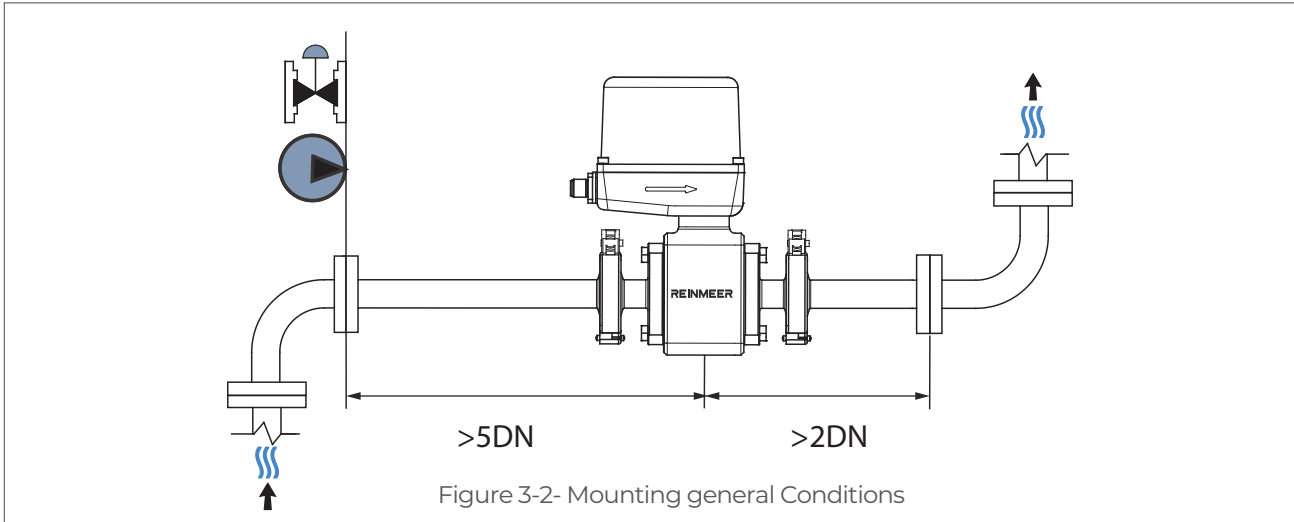

INSTALLATION AND ASSEMBLY | MAGFIL

Electromagnetic flowmeters can be mounted on pipes of larger or smaller diameters; furthermore, the dimensions and weight of the sensor must be considered when mounting the device on a pipeline. The table below shows the correct general mounting conditions.

Inlet Run	> 5 DN
Outlet Run	> 2 DN
Process connections	3A Clamp 19mm for Magfil15 model 3A Clamp 25mm for Magfil25 model

According to the table:

- (i) The minimum required distance upstream of the sensor (to equipment such as valves, pumps, and T-junctions) must be 5 times the pipe diameter (5 x DN).
- (ii) The minimum required distance downstream of the sensor (to equipment such as valves, pumps, and T-junctions) must be 2 times the pipe diameter (2 x DN).

3.3 Orientation of the measuring electrodes

In all mounting poses the optimum measurement takes place when the pipe system is completely filled with the medium so the measuring electrode in horizontal pipe lines plane must be horizontal. This prevents brief insulation of the two measuring electrodes by entrained air bubbles.

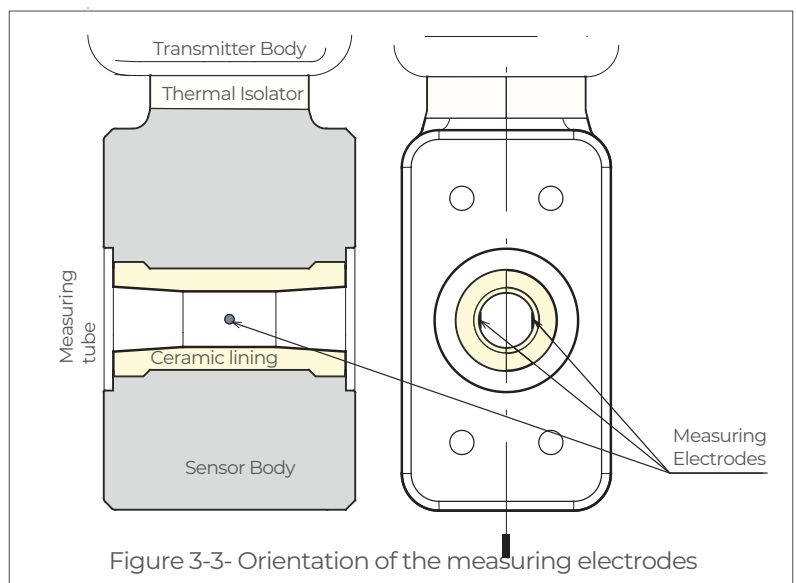

3.4 Reduced pipe line diameter

In the case of using pipe diameter reducers, a pressure loss occurs and the velocity of fluid passing through the sensor increases and this leads to preventing the liquids to produce coating on the internal wall of the pipe line and consequently the measurement accuracy improves. Figure 3-4 illustrates the pressure loss due to the diameter reduction.

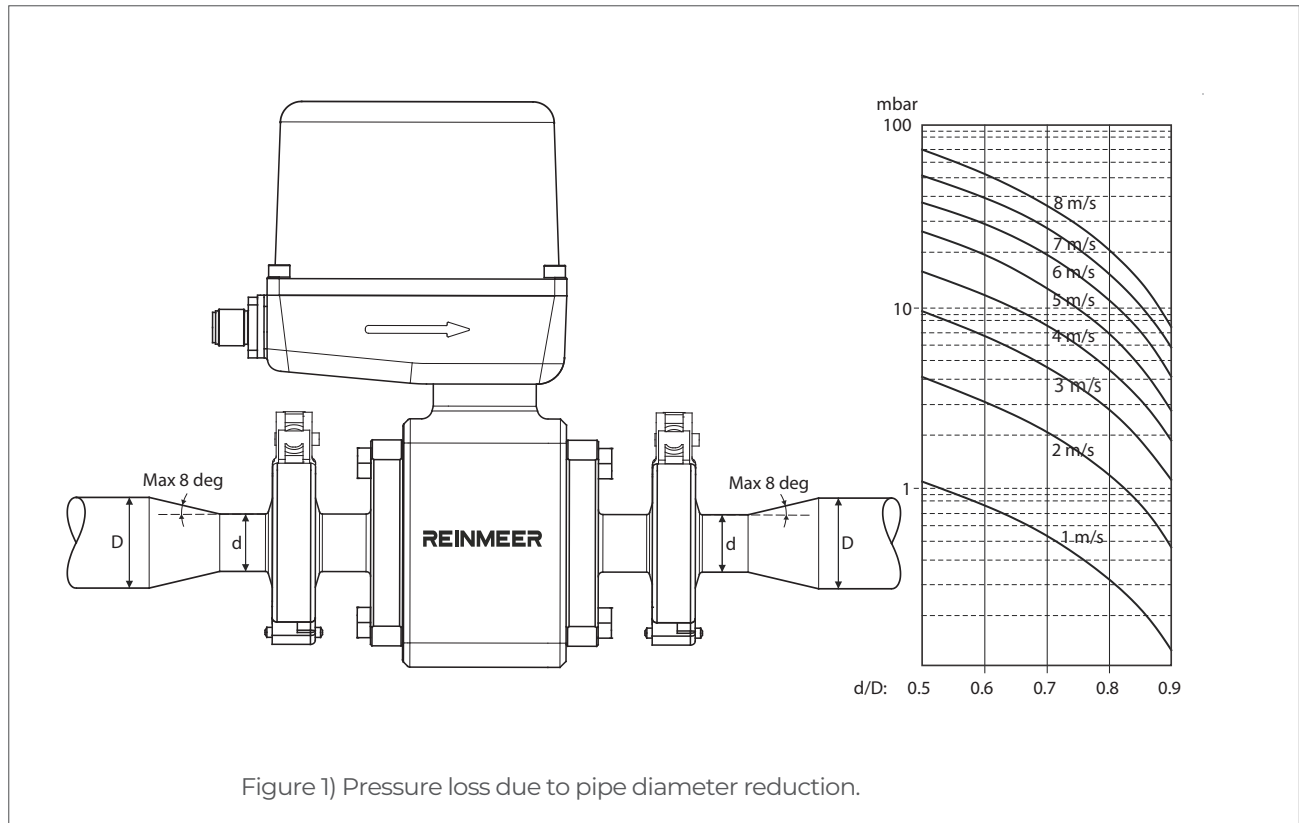

Figure 1) Pressure loss due to pipe diameter reduction.

- i The minimum required distance before the sensor until the reducer must be 5 times of the main pipe diameter.
- i The minimum required distance after the sensor until the reducer must be 2 times of the main pipe diameter.

3.5 Different mounting situations

3.5.1 Siphon shaped pipe Installation

To avoid air bubble to aggregate in the sensor mounting position one can install the sensor on a U shaped siphon pipe line as below.

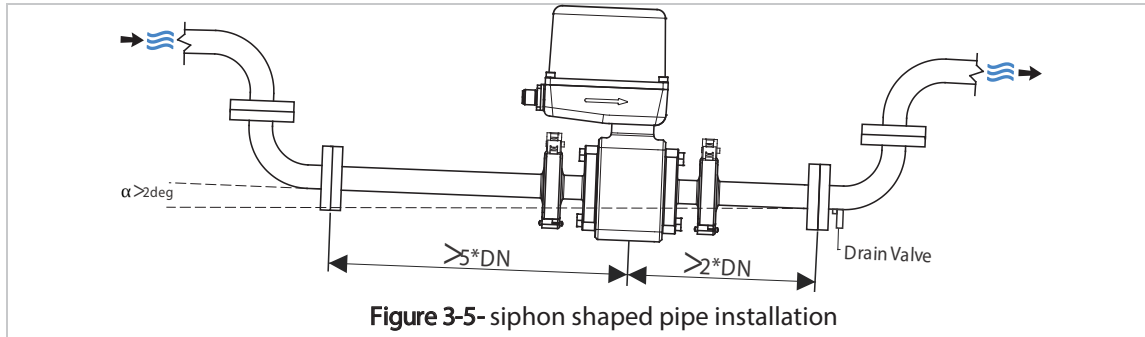

3.5 Different mounting situations

It is extremely recommended that in the case of open discharge the u shape siphon with slightly angled installation position is needed.

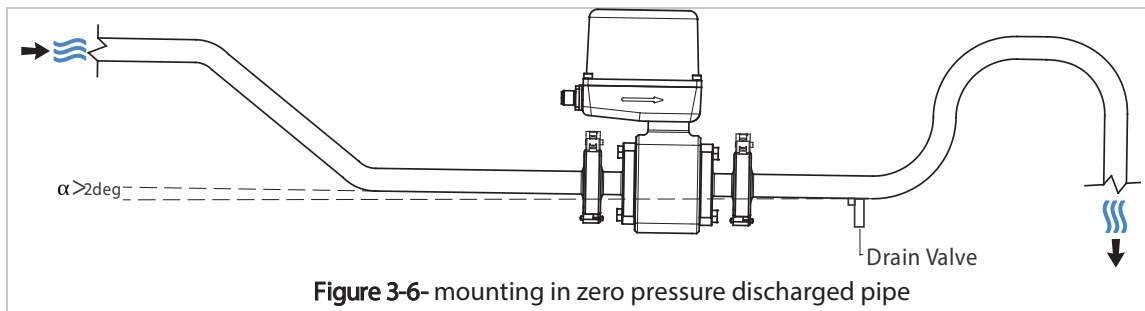

3.5.3 Installation before control valve

Do not install the sensor after control valves.

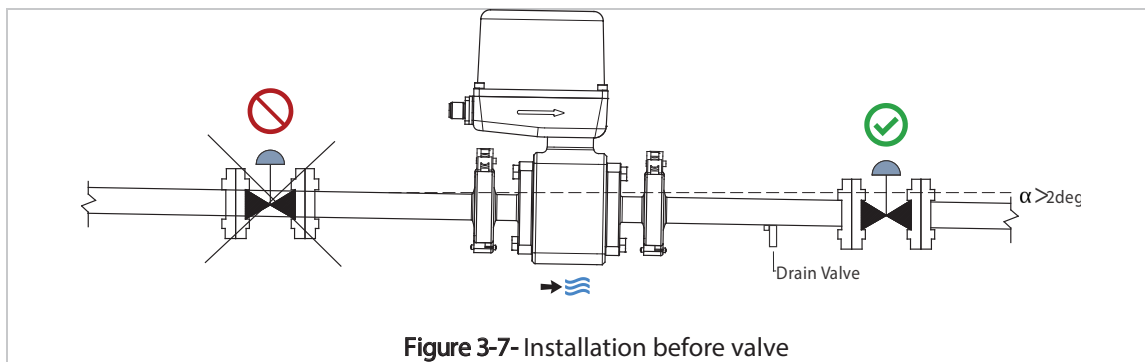

3.5.4 Installation after pump

Do not install the sensor before pumps.

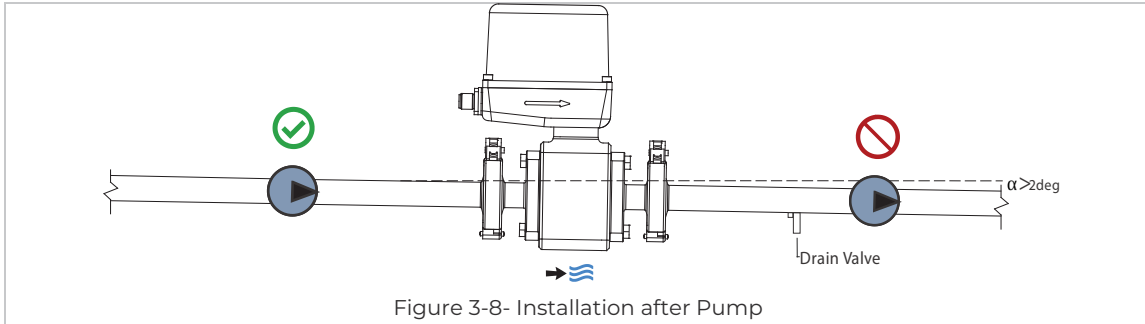

3.5.5 Different mounting positions along a pipe

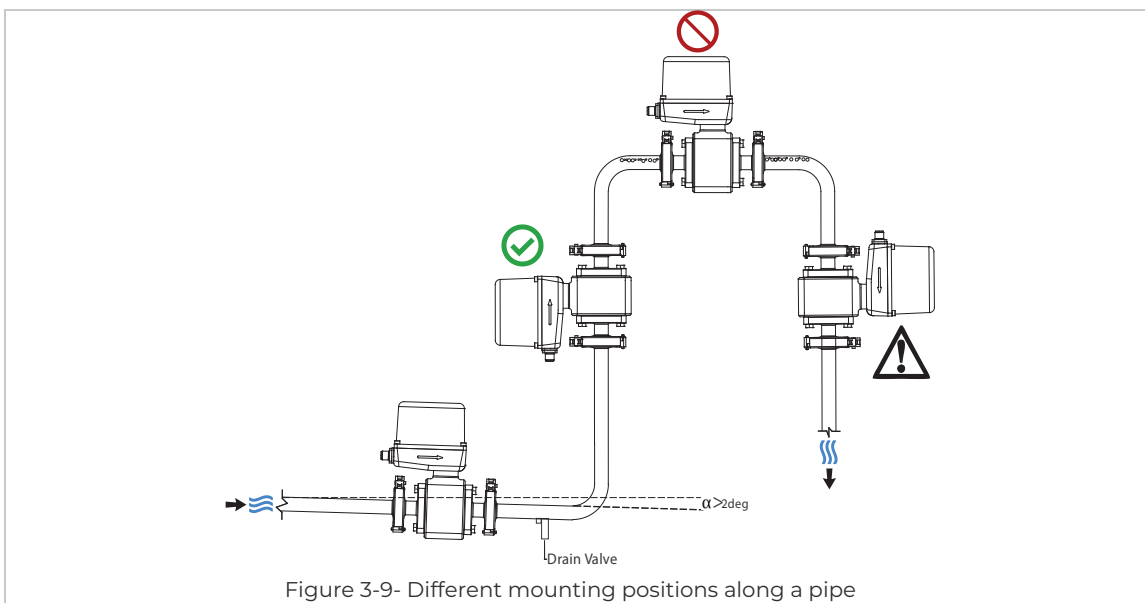

⚠ Vertical downward flow position only in conjunction of a control valve.

3.5.6 Downward pipes mounting

Install a siphon with a vent valve downstream of the sensor in down pipes whose length $h \geq 5m$. This precaution is to avoid low pressure and the consequent risk of damage to the measuring tube. This measure also prevents the bubbles too.

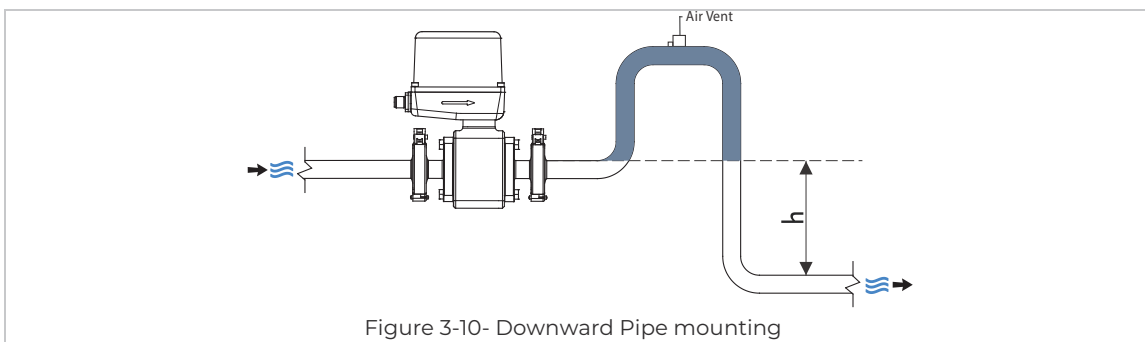

3.5.7 Extremely heated pipe lines

The transmitter unit pointing downward reduces the risk of the electronic components overheating in the case of mounting on extremely hot process medium.

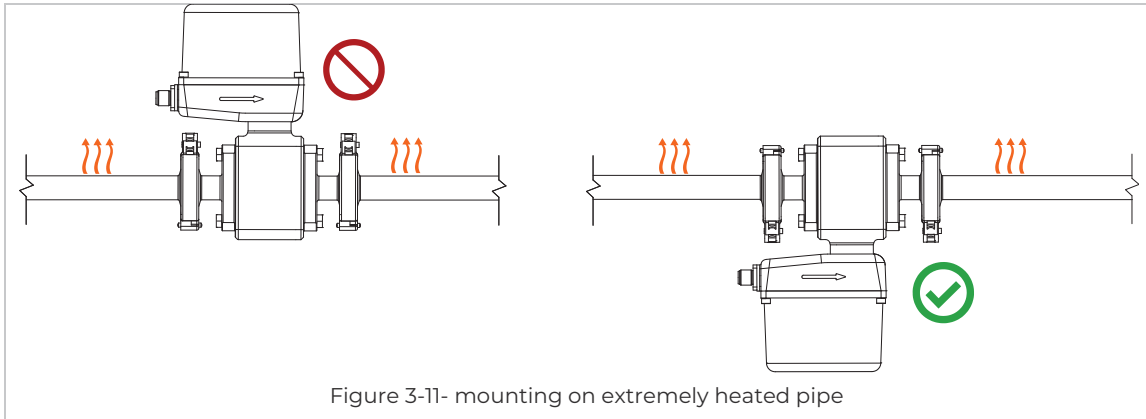

3.6 Mounting on a partially filled pipe with immersed solid particles

In the case of solid particles in the medium a drain for solid particles is necessary.

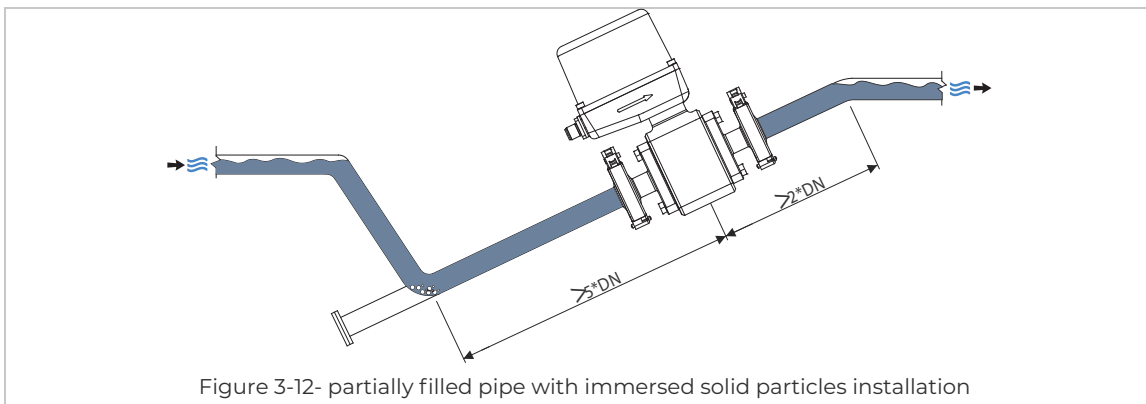

3.6.1 Prohibited mounting situations

Avoid to mount the device on pipe lines with extreme mechanical vibrations or in the existence of powerful magnetic fields.

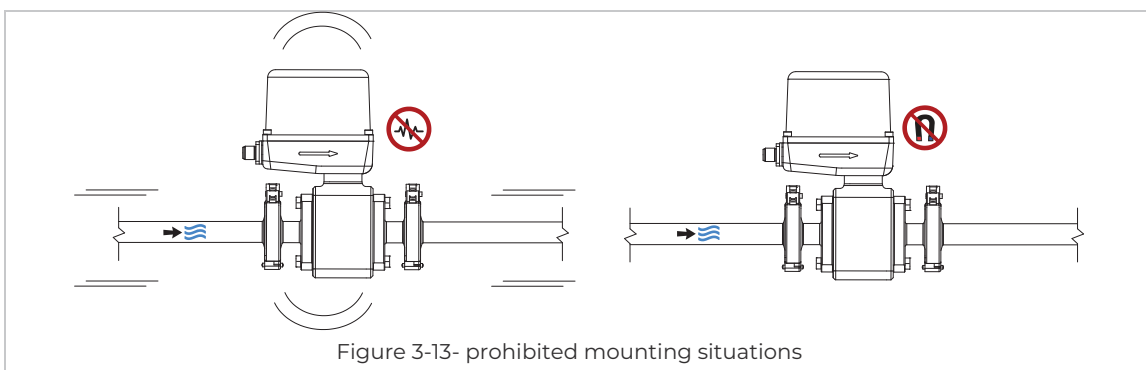

3.6.2 Batching setup

Remfil flowmeters can be mounted in batching machines with different postures as Figure 3-14 below.

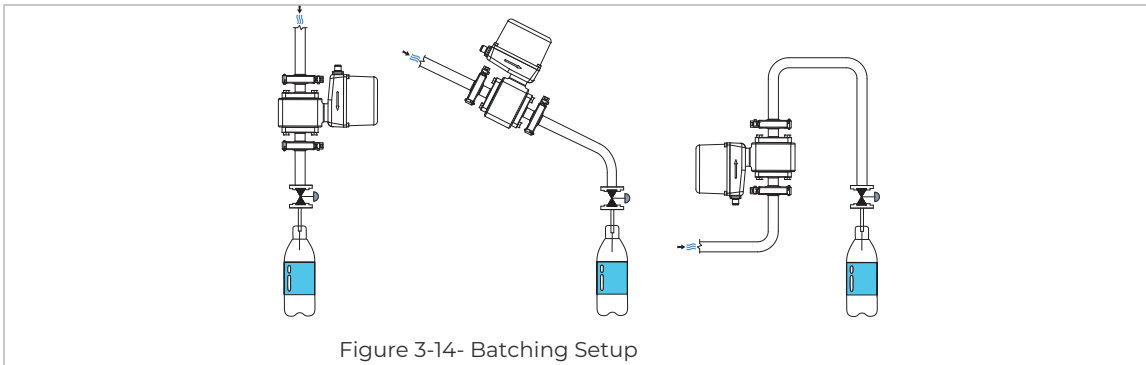

3.6.3 Mounting on Linear filling machine

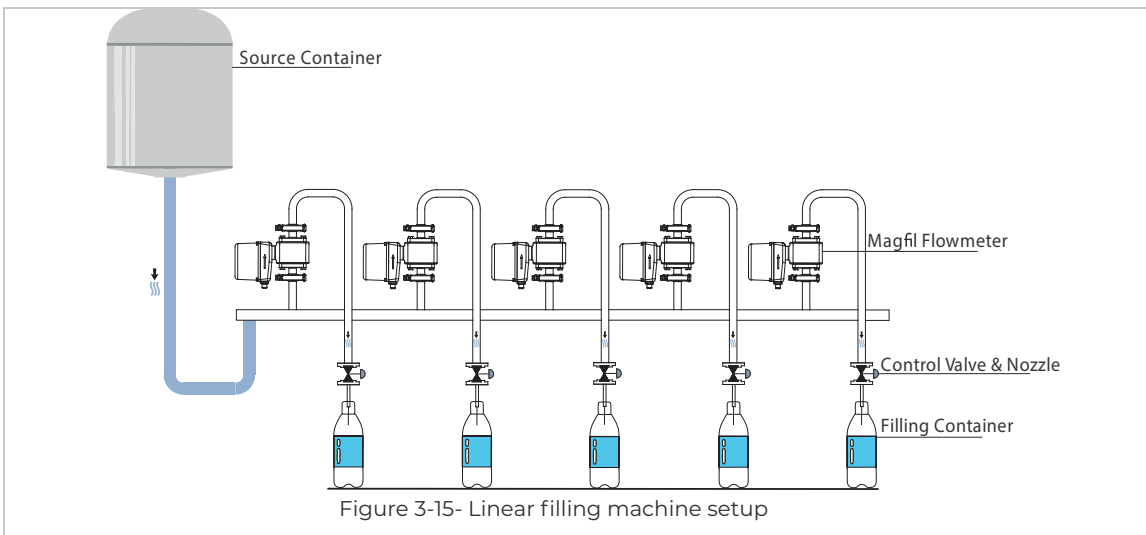

3.6.4 Mounting on rotary filling machine

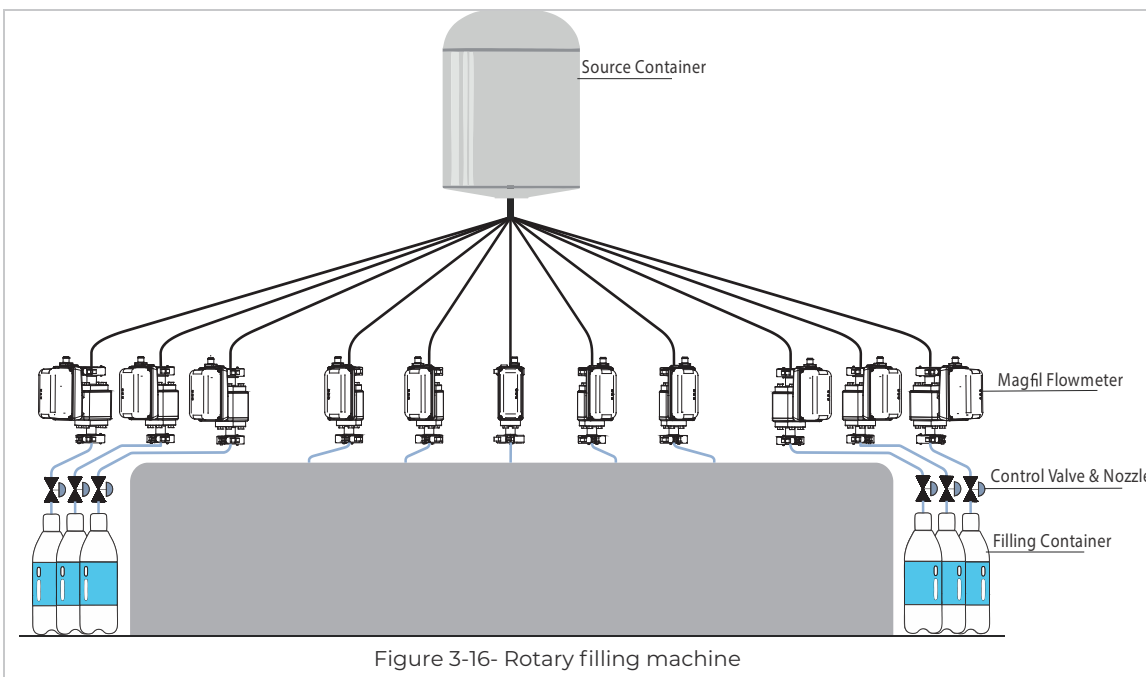

4. Input/Outputs and Wiring

4.1 Cable male connectors

Reinmeer Remfil flowmeters can be powered and connected to other devices with M12 connectors.

There is two options for M12 connectors depending on the order, 5pin connectors and 8 pin connector which have been illustrated in Figure 4-1, Figure 4-2 and Figure 4-3.

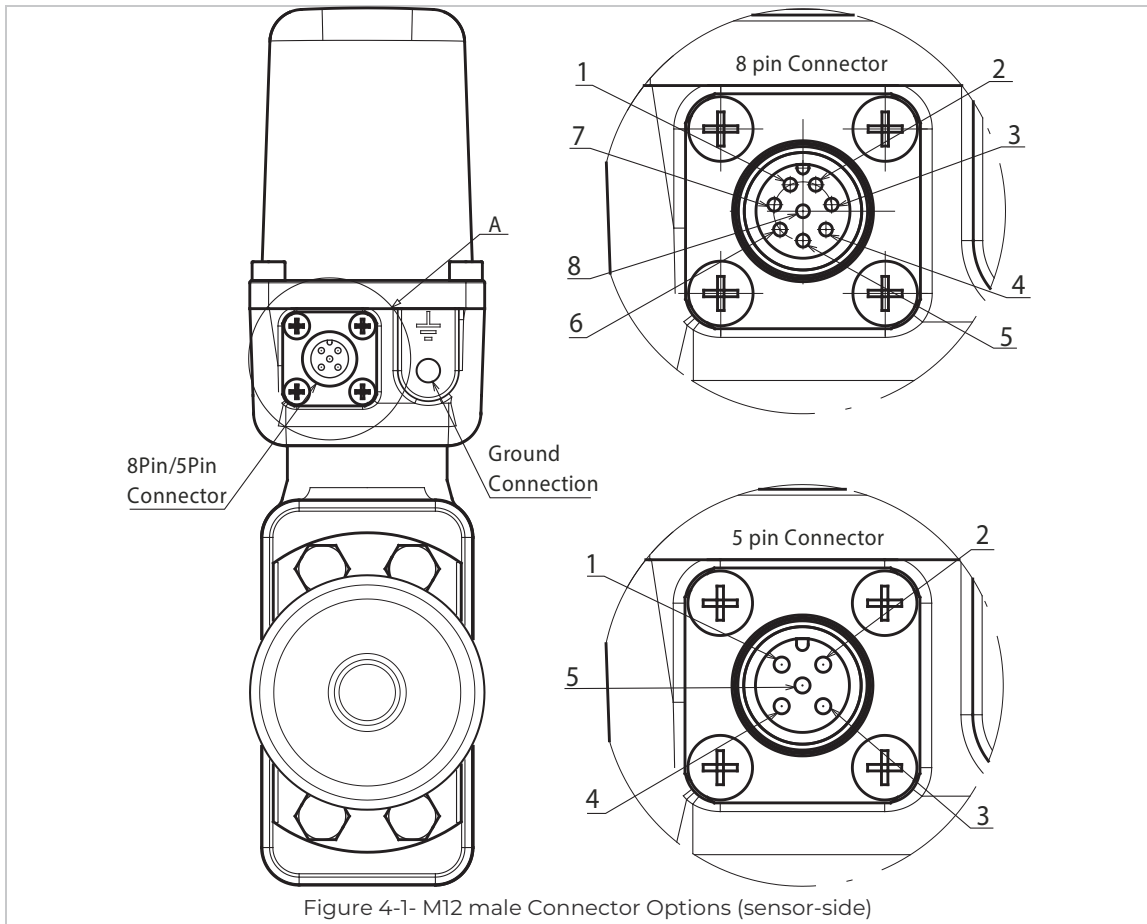

Figure 4-1- M12 male Connector Options (sensor-side)



Ground Connection is located beside the M12 connection and the cable must be attached to it by a M6*8 bolt.

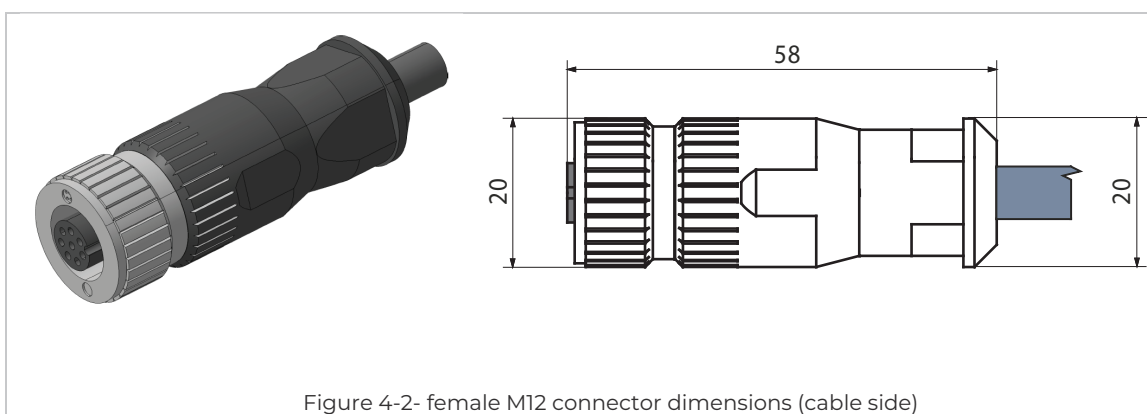
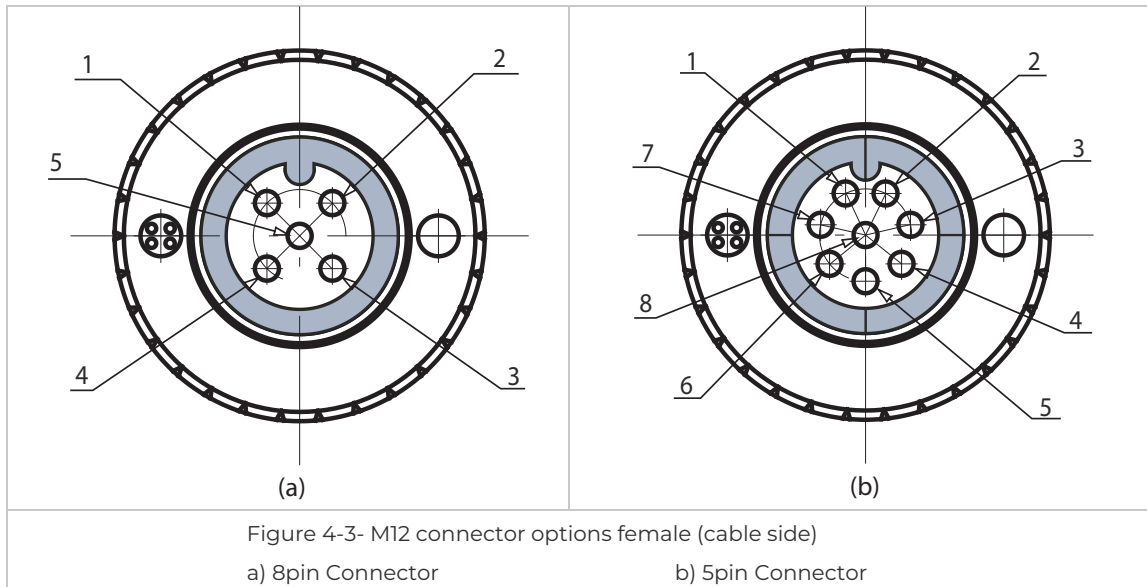

Figure 4-2- female M12 connector dimensions (cable side)



- ⚠ The power input for all flowmeter models must be 22-26VDC with the minimum current supply 100mA (terminals 1,4).
- ℹ One can configure the outputs mode into their desires with the available parameters via Modbus communication or using HMI unit. See section 5 “Setting using the HMI unit and Modbus network”.
- ℹ The instrument can be used in a Modbus RTU network using the RS485 hardware (terminals 6 and 7 in 8pin Models).
- ℹ Reinmeer Remfil flowmeters can control a pneumatic valve using its digital output (terminal no 3) via a Relay or SSR.
- ℹ Never connect the digital output to the pneumatic valve directly because it cannot endure currents more than 50mA.

4.2 Wiring Diagrams

According to the different operation modes which is defined via Modbus network or using the HMI unit, each model of Remfil electromagnetic flowmeter has a different wiring configurations.



For define the operation modes see section 5 Setting using the HMI unit and Modbus network.

4.2.1 Wiring diagram for Remfil xx-1DO1AO-8

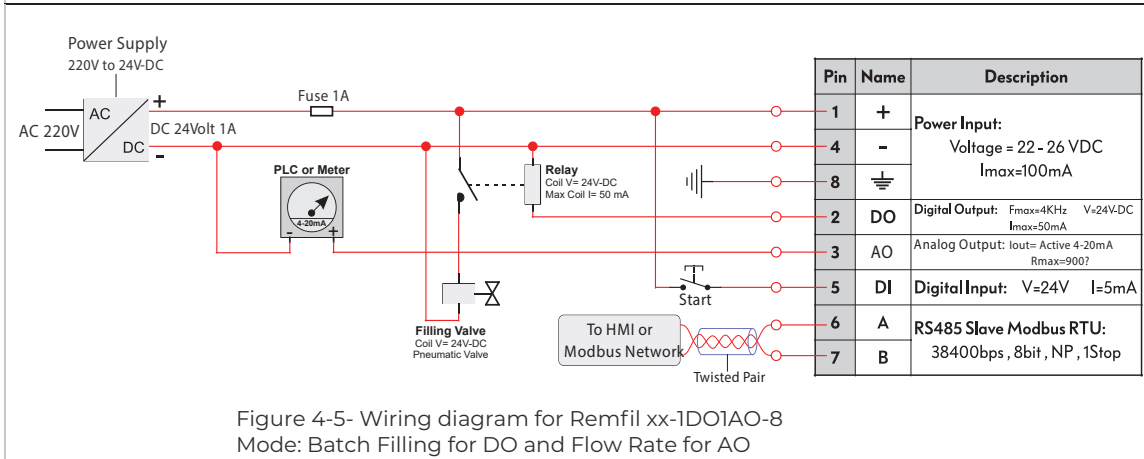
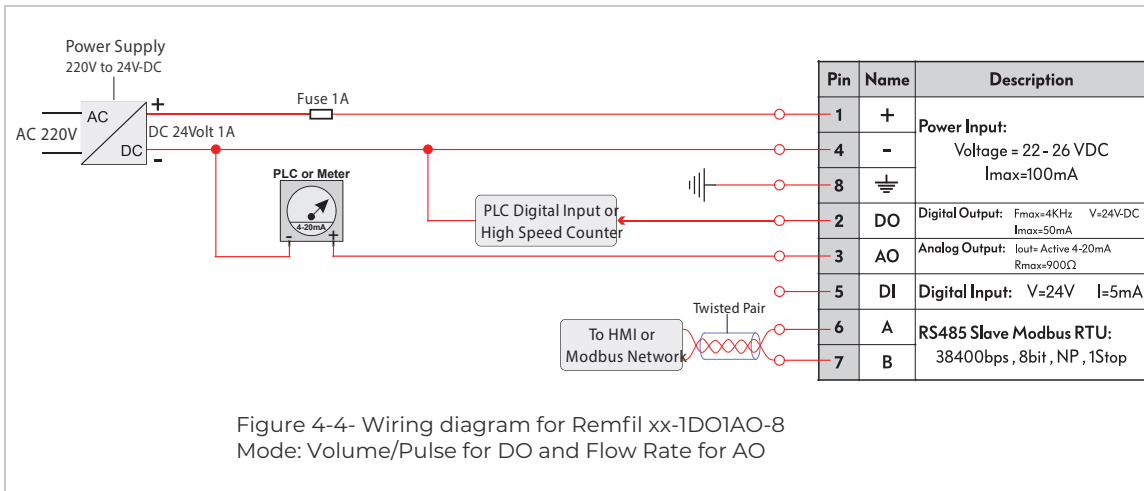

4.2.2 Wiring diagram for Remfil xx-2DO-8

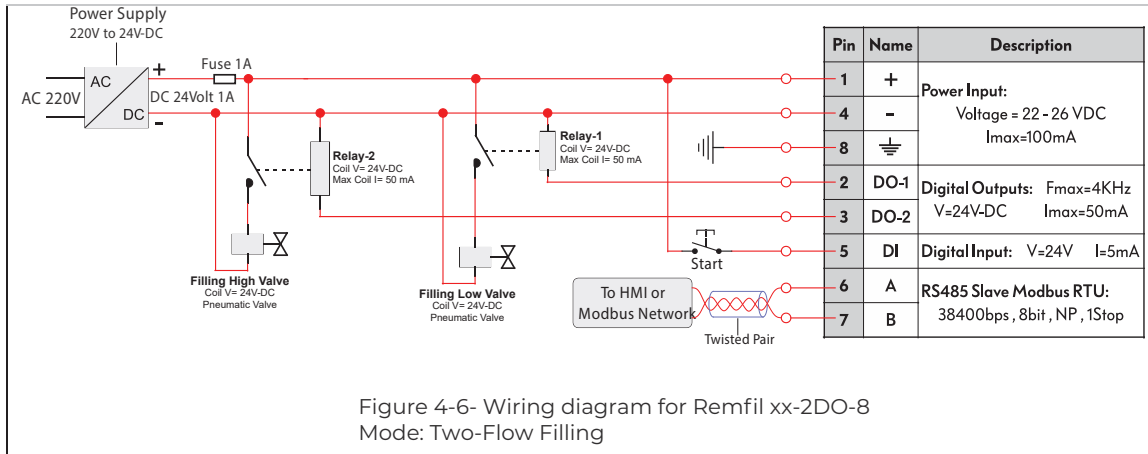

Figure 4-6- Wiring diagram for Remfil xx-2DO-8 Mode: Two-Flow Filling

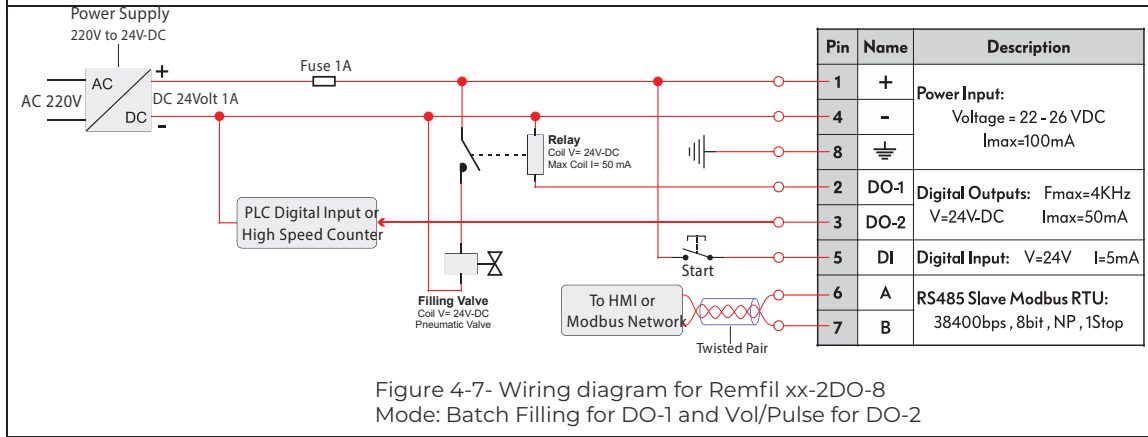

Figure 4-7- Wiring diagram for Remfil xx-2DO-8 Mode: Batch Filling for DO-1 and Vol/Pulse for DO-2

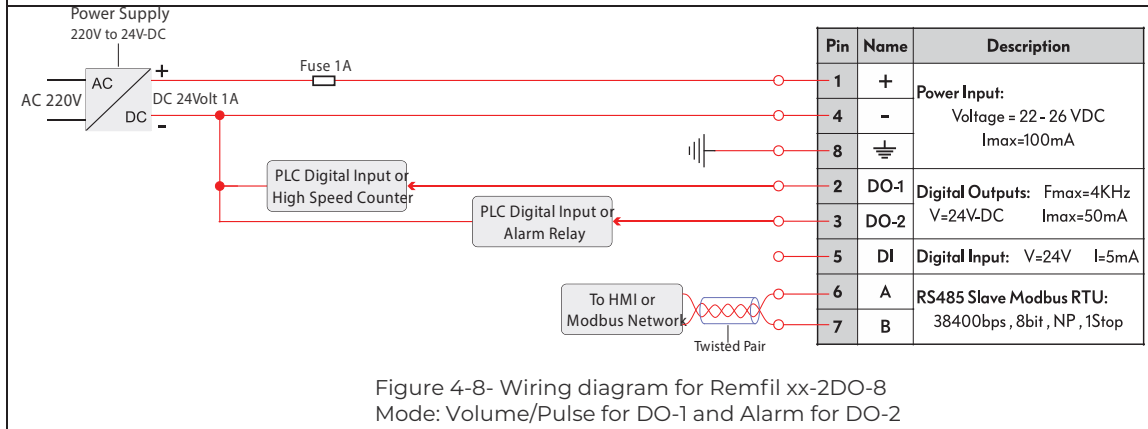

Figure 4-8- Wiring diagram for Remfil xx-2DO-8 Mode: Volume/Pulse for DO-1 and Alarm for DO-2

4.2.3 Wiring diagram for Remfil xx-1DO-8

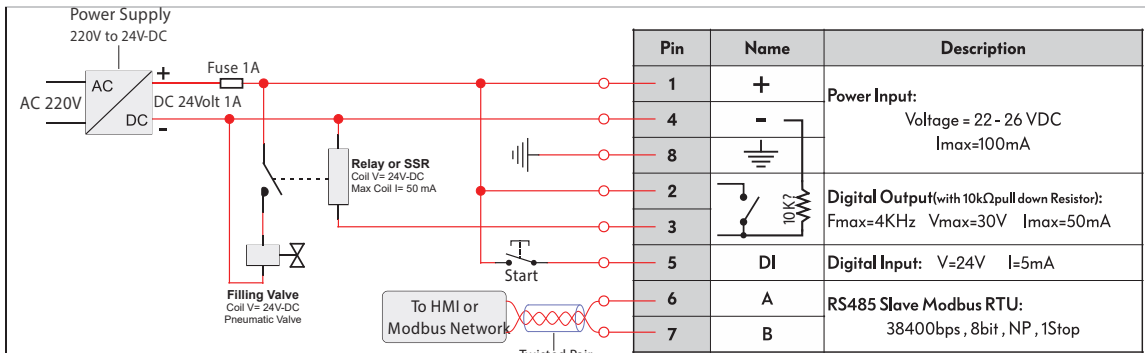

Figure 4-9- Wiring diagram for Remfil xx-1DO-8
Mode: Batch Filling

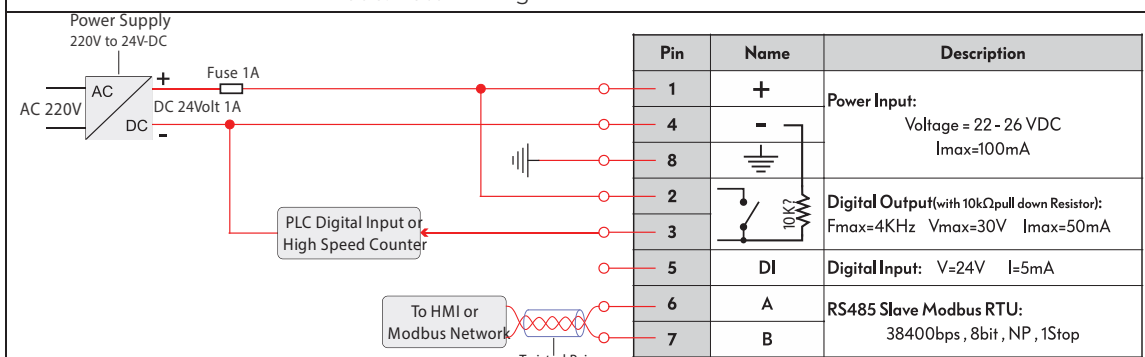

Figure 4-10- Wiring diagram for Remfil xx-1DO-8
Mode: Volume/Pulse , Active High(Source)

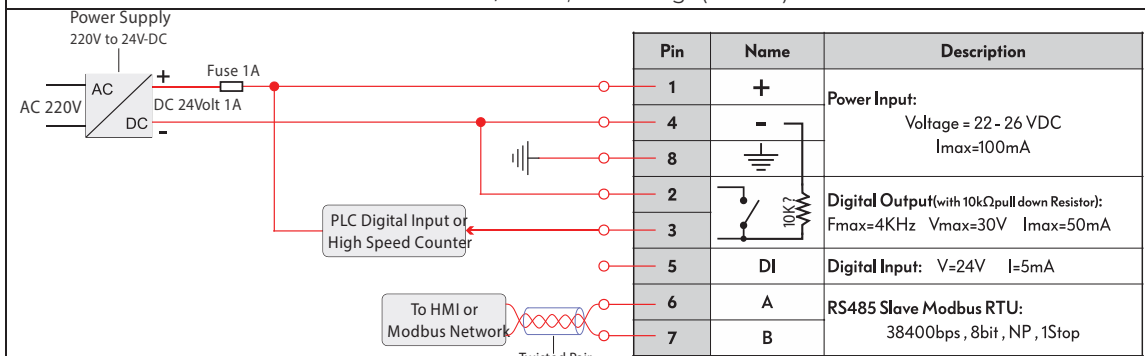

Figure 4-11- Wiring diagram for Remfil xx-1DO-8
Mode: Mode: Volume/Pulse , Active Low(Sink)

4.2.4 Wiring diagram for Remfil xx-1DO-5

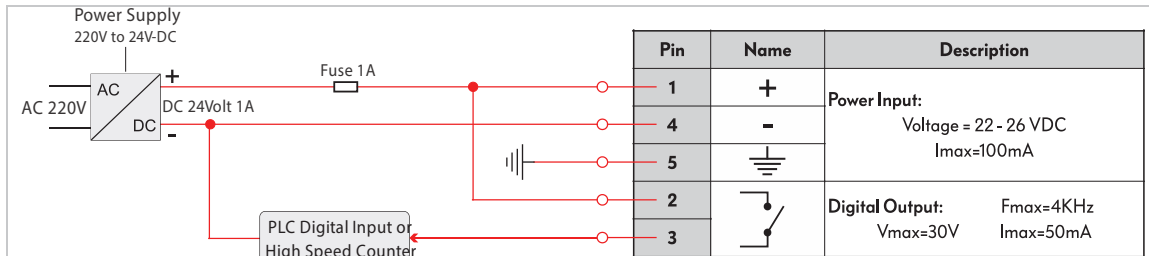

Figure 4-12- Wiring diagram for Remfil xx-1DO-5
Mode: Volume/Pulse, Active High (Source)

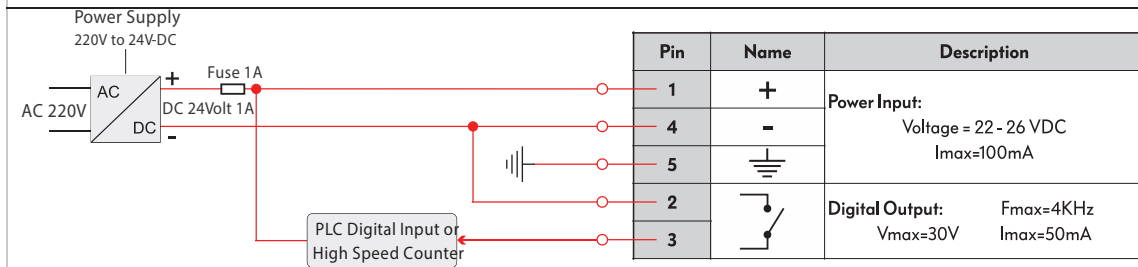

Figure 4-13- Wiring diagram for Remfil xx-1DO-5
Mode: Volume/Pulse, Active Low (Sink)

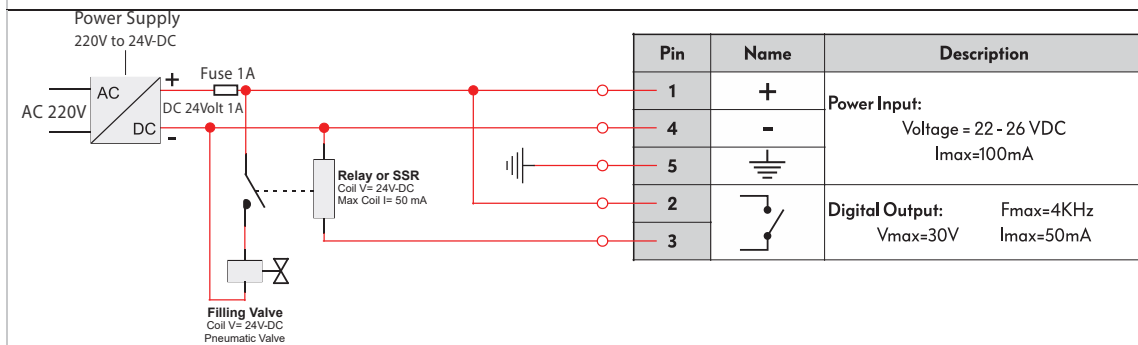

Figure 4-14- Wiring diagram for Remfil xx-1DO-5
Mode: Batch Filling

4.4 Hardware configuration diagram for Three-State Filling (Remfil XX-2DO-8)

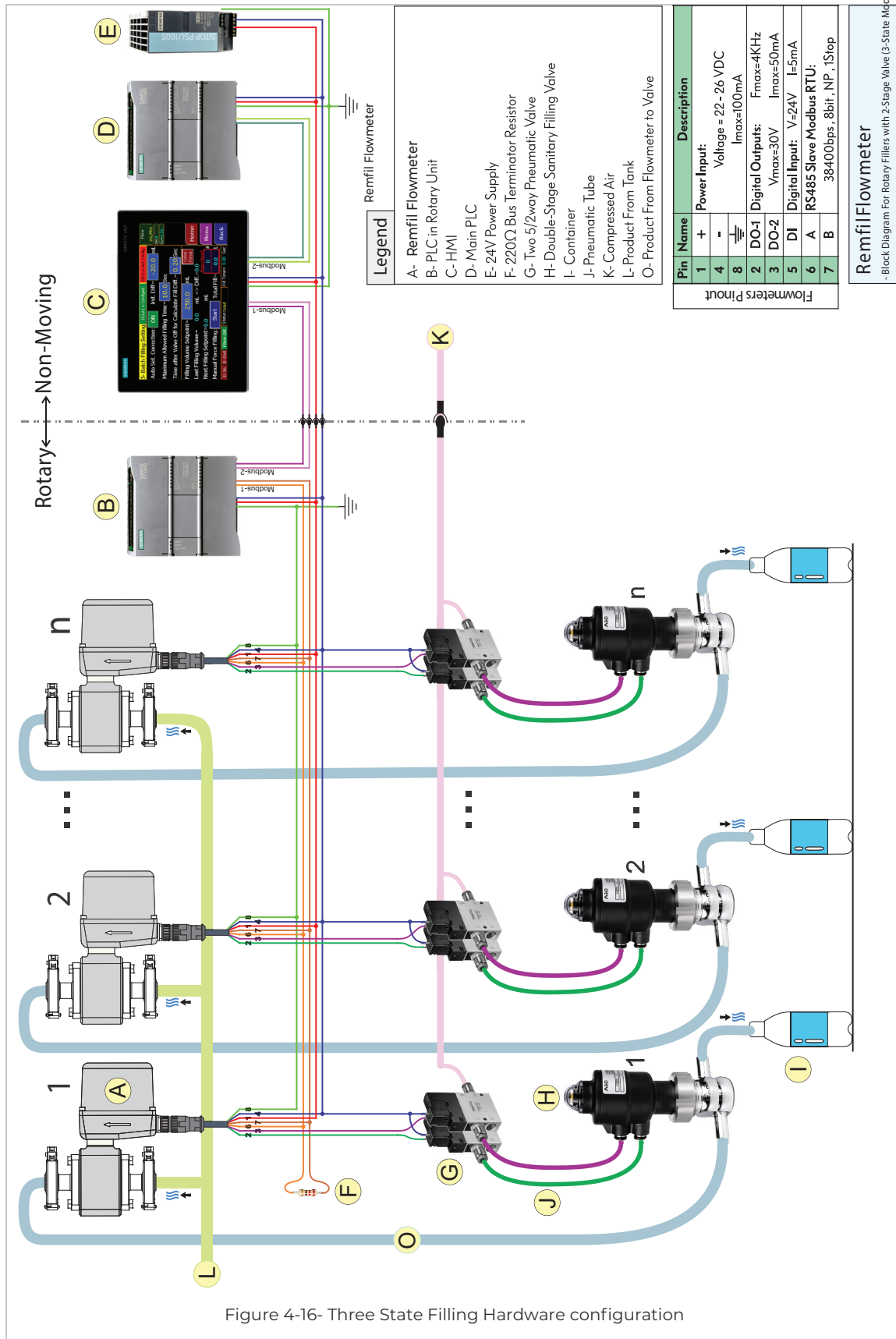

Figure 4-16- Three State Filling Hardware configuration

5- Setting using the HMI unit and Modbus network

Reinmeer Remfil electromagnetic flowmeters can be connected to a Human Machine Interface (HMI) touch panel using the RS485 ports (terminals 6 and 7 in 8pin models) via the serial Modbus RTU network. With this capability the user has access to the setting of the instrument, can check the calibration and see different measuring and diagnostic parameters in real time.

i The HMI unit can be ordered with the instrument.

5.1 HMI main page

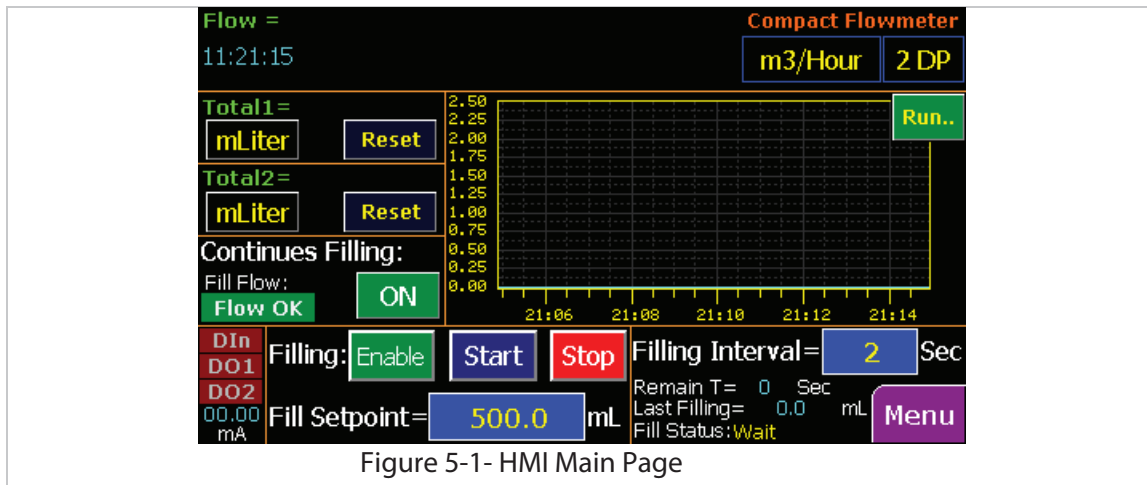

Figure 5-1- HMI Main Page

Flow	The real time flow rate	Menu	The setting page of the device
Total1	Magnitude of totalizer 1	FillSetpoint	Set point of filling
Total2	Magnitude of totalizer 1	Last Filling	Magnitude for the last filled container
Remain T	Remaining time until the next filling cycle (when Continues Filling is ON)		
Continues Filling	When continues filling is ON ,after finishing one filling cycle, the device waits as long as parameter Filling Interval and then the next cycle will be started. The filling process will be continued until you press Stop button. Otherwise if this button is OFF pressing of the start button opens the valve to fill one container with the volume "Filling Volume Setpoint" and then the filling process stops.		
Filling (Enable / Disable)	The Start button can be pressed from this page only if filling state is Enabled		
Filling (Start / Stop)	Start and Stop button for filling cycle.		
Fill Status	Wait	Filling program is waiting to start with Digital input or Start button	
	Filling	Valve is open and filling is in progress	
	OFF Filling	Valve is closed and flowmeter is waiting for the flow to zero	
	Interval	Waiting to elapse interval time and begin a new filling cycle (This status is only for continues filling mode)	

- i** The real time flow rate is plotted on the chart displayed in the right side of this page.
- i** The totalizers unit can be changed using the button under the totalizer magnitude.
- i** One can reset the totalizers using the reset button bellow it

5.2 Input and Output Setting

To access the Input and Output Setting follow the bellow path:

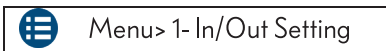

In this page settings of the Digital Outputs, Digital inputs, analog output, serial output, and digital input can be done.

5.2.1 Status LED Mode

Status LED (see section 2.13 Indicator LEDs) function can be configured using the “Status LED” multistate button on bellow of the In/Out Setting Page. The States of the LED is expressed bellow:

Disable	Always OFF
Flow Rate (0-35Hz)	Simulates flow rate from 0 to full scale with LED blinks from 0 to 35 times per second.
Modbus Communication	LED Blinks while Modbus communication
Digital Output Status	LED is ON when Digital Output is ON
Digital Input Status	LED is ON when Digital Input is ON

i Restart the flowmeter after changing the “Status LED Mode”.

5.2.2 Digital input setting

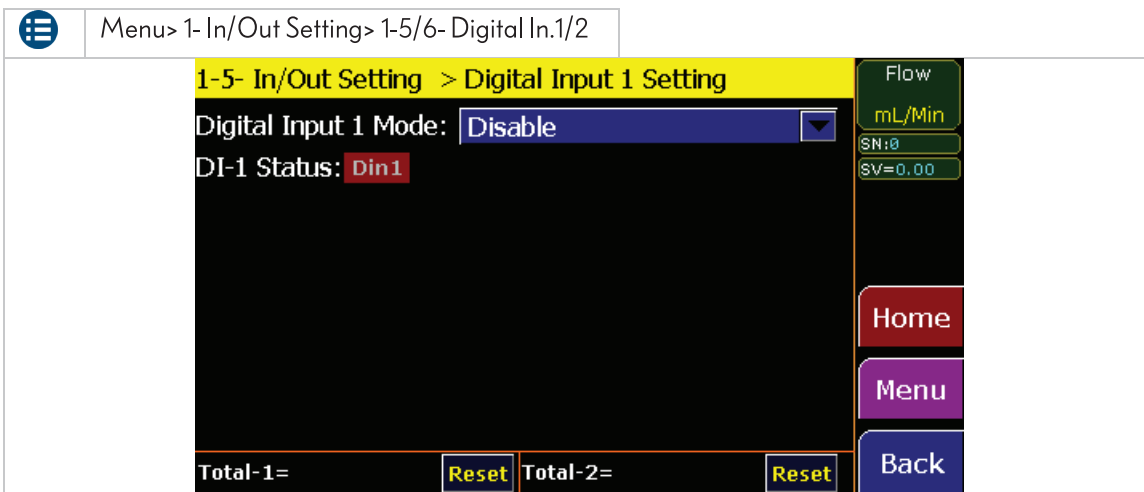

Figure 5-2- Digital Inputs Setting page

Parameter	Range	Explanation
Digital Input Mode	Disable	No function
	Totalizer1/2 reset	Resets the totalizer when digital input becomes ON
	Totalizer1/2 Hold	Holds the totalizers magnitude while the Digital input is ON
	PID Enable	Enables the PID Controller
	Filling Start	Filling cycle starts by rising edge of the Digital Input
	Filling Start and Stop	Filling cycle is ON while the Digital input is ON otherwise it remains OFF.

5.2.3 Digital output setting

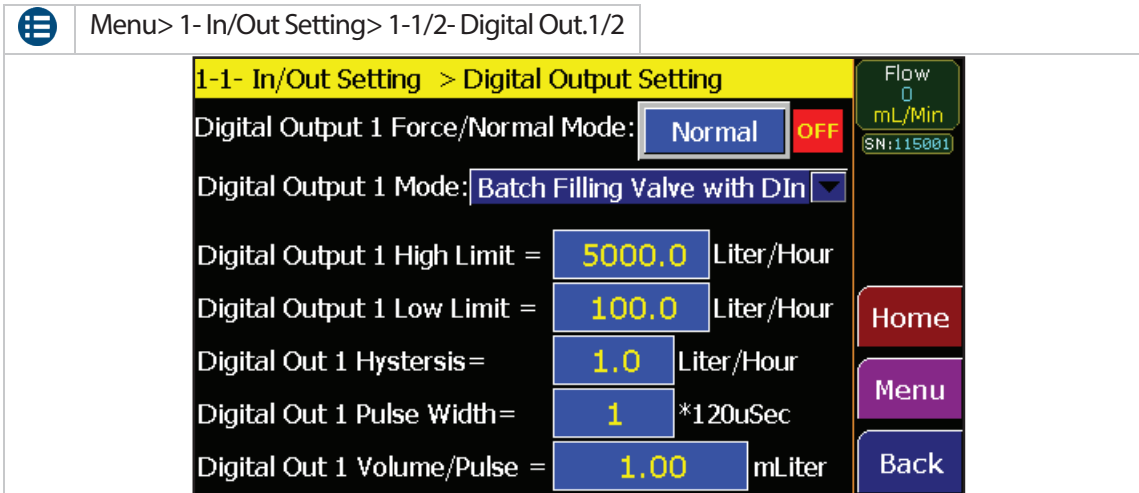

Figure 5-3- Digital Output Setting page

Parameter	Range	Explanation
Digital Output Force/Normal Mode	Normal	Automatically controlled according to Digital Output mode
	Force ON/OFF	Manually forces the digital output ON/OFF.
Digital Output Mode	Disable	Always Off
	Digital Output High Limit	When the flow rate exceeds the High Limit specified in this page the digital output turns ON and when it falls below the High Limit minus the Hysteresis turns OFF.
	Digital Output Low Limit	When the flow rate falls from the Low Limit specified in this page the digital output turns ON and when it exceeds the Low Limit plus its Hysteresis turns OFF.
	Flow Out of Range	When the Flow rate goes outside of the range specified by High Limit and Low Limit it turns ON otherwise it remains OFF.
	System is OK	Remains ON while system is running normally.
	Volume Pulse	Output provides pulse with the Pulse width and Volume/Pulse parameters which is defined in this page corresponding to the flow rate.
	Total 1 Limit, Total 2 Limit	Digital Output turns ON if totalizer value is greater than "Totalizer Limit" (See Section 5.4 Totalizers Setting).
	Batch Filling Valve with DIn	Turns ON to open the batch filling valve. (See section 5.6)
	Two Flow FillLow Valve	(See section 5.7)
	Two Flow FillHigh Valve	(See section 5.7)

- ① The Hysteresis value indicates how soon the state of digital output changes after the process has gone over or under the specified limit. For example if the high limit is 50 and the hysteresis is 2 the output turns ON when the flow rate exceeds 50 and turns OFF when it becomes 48.
- ① Using parameter Digital Out Volume/Pulse one can indicates the amount of volume passing through the flowmeter that the digital output produces one pulse for that.

5.2.4 Analog output setting

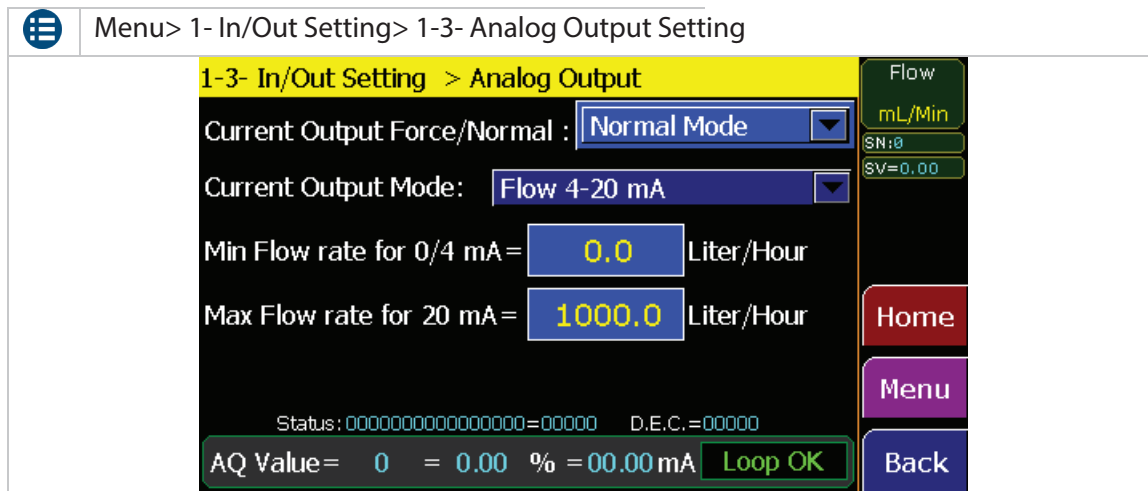

Figure 5-4- Analog Output Setting page

Parameter	Range	Explanation
Current Output Force/Normal Mode	Normal Mode	Automatically transmits the output according to <i>Output Mode</i>
	Force 0, 4, 8, ... , 20 mA	Forces the analog outputs to 0, 4, 8, ... , 20mA for test purposes.
Current Output Mode	OFF	Always transmits 0 mA
	Flow 0 ~20 mA	0~20mA proportional to Flow rate
	Flow 4 ~20 mA	4~20mA proportional to Flow rate
	PID 0~20 mA	0~20mA proportional to PID output
	PID 4~20 mA	4~20mA proportional to PID output
Min Flow rate for 0/4 mA	Minimum limit of Flow rate proportional to 0/4 mA	
Max Flow rate for 20 mA	Maximum limit of Flow rate proportional to 20 mA	

- ⓘ If there is an interruption on the analog output wire, the “Loop OK” on the right bottom of the page changes to “Open Loop”.

5.3 Calibration Setting

5.3.1 Field Calibration

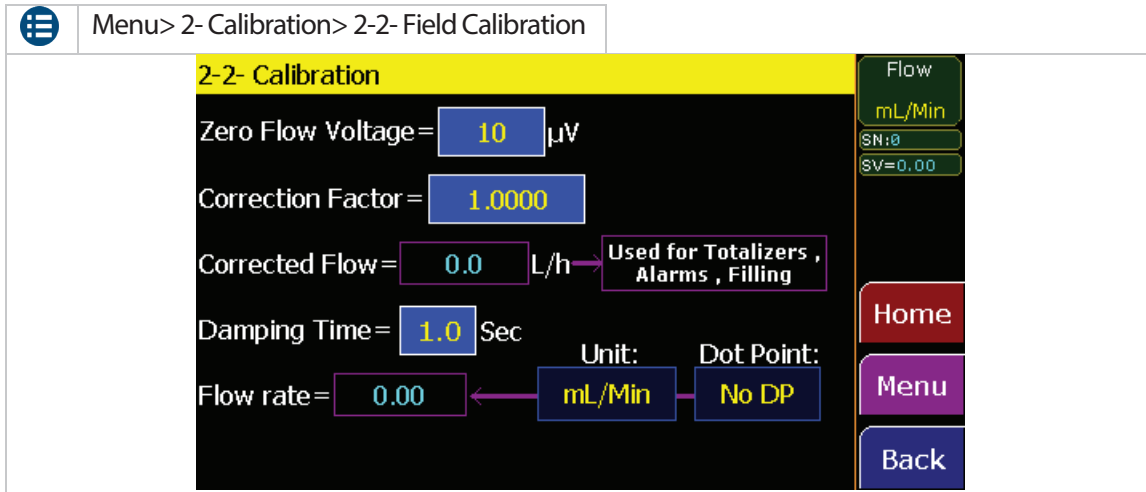

Figure 5-5- Field Calibration page

Parameter	Range	Explanation	Default Value
Zero Flow Voltage	0-65535	This parameter is the maximum electrode voltage when liquid flow is zero. (Low cut-off electrode voltage)	0
Correction Factor	0.0001-9999.9999	This parameter is multiplied to the initially measured flow rate to calculate the real flow rate	1.0000
Corrected Flow	Flow rate after calibration.		
Damping Time	0.1-20.0	The time that the measured flow is averaged out	10
Flow Rate	Current flow rate passing through the sensor		
Unit	Liter/Hour, Liter/min, Liter/sec, m3/Hour, m3/min, mL/min, mL/sec	Unit of the parameter Flow rate in this page	Liter/Hour
Dot Point	No DP, 1DP, 2DP, 3DP	Number of dot points of the parameter Flow rate in this page.	No DP

5.3.2 Diagnostics Page

The diagnostics parameters page shows the general working condition of the device. In the case of any problem or fault in the operation of the device these parameters can be used for diagnostics.

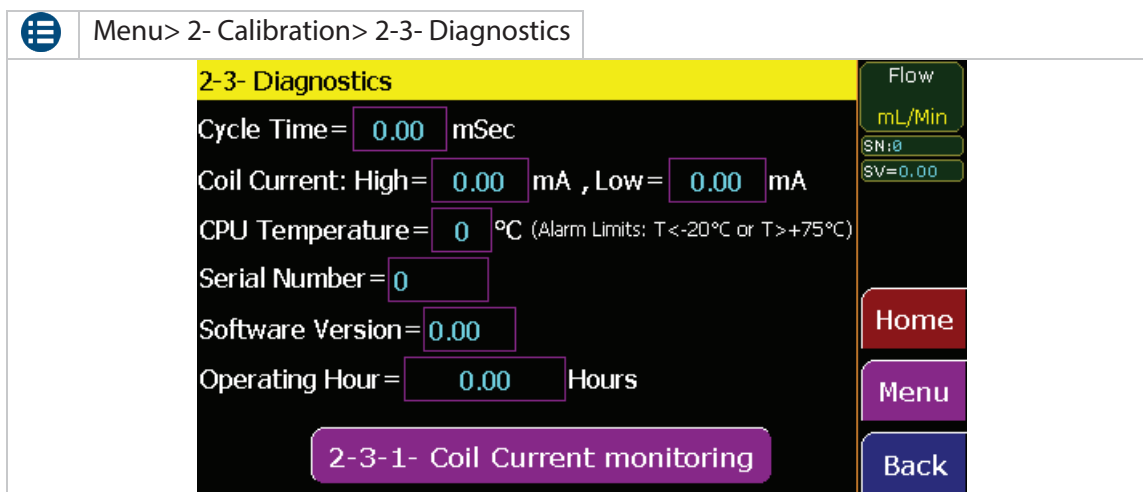

Figure 5-6- Diagnostics page

Parameter	Explanation	Nominal Value
Cycle Time	Central microcontroller software cycle time	Less than 10ms
Coil Current	High	Positive and negative current passing through the sensor coil
	Low	
CPU Temperature	The temperature of the central microcontroller.	Less than 70°C
Serial Number	Device serial number	
Software Version	Microcontroller's software version.	
Operating Hour	The time duration that the sensor have been powered on.	

- ① If each one of the parameter in this page was out of the range specified at "Nominal Value" column contact your local Reinmeer service.
- ① The coil current graph is shown on the page "2-3-1- Coil Current monitoring" at the bottom of "diagnostics page".

5.4 Totalizers Setting

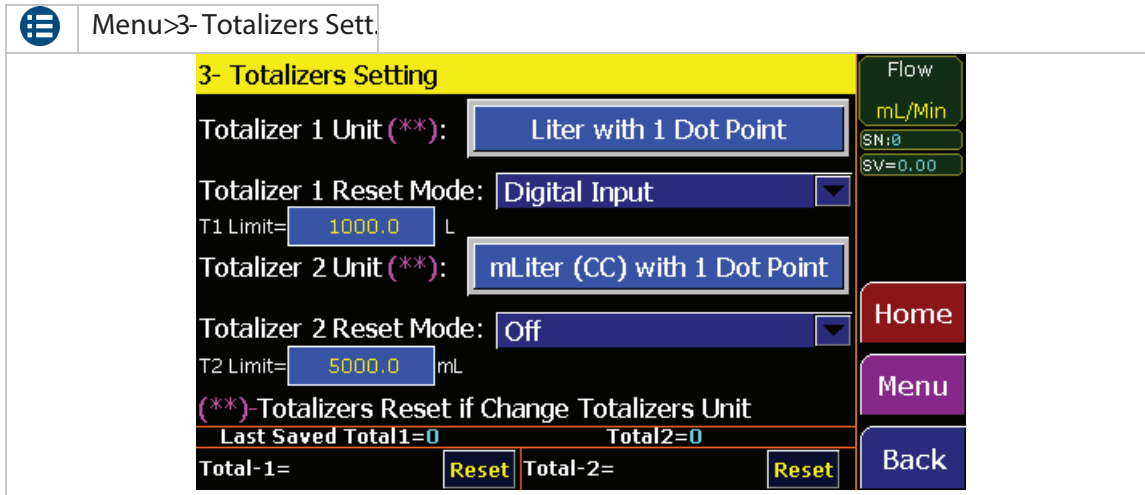

Figure 5-7- Totalizers Setting page

Parameter	Range	Explanation
Totalizer1/2 Unit	Liter with one Dot Point m ³ with 3 Dot Point mLiter (cc) with one Dot Point	Multistate button for changing the totalizer unit.
Totalizer1/2 Reset Mode	Off	Totalizer never reset
	Setting Page	Reset with the push buttons bellow of this page.
	Digital Input	Reset with Digital Input (See section 5.2.2 Digital Input setting)
	Setting Page & Digital In.	Reset with both of the above options.
	Reset On Limit	Totalizers will be reset when it reaches its limit specified as "T1/2 Limit" in this page.
T1/2 Limit	0.0~99999999.9	Max allowed limit for totalizers

ⓘ If you change the Totalizers unit in this page, the totalizers will be reset.

5.5 Display Setting

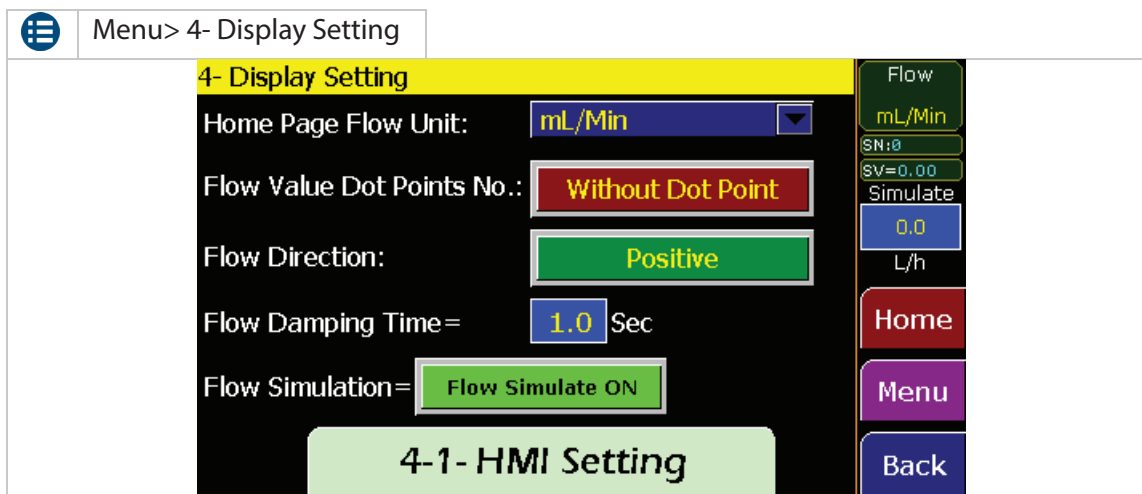

Figure 5-8- Display Setting page

Parameter	Range	Explanation
Home Page Flow Unit	Liter/Hour, Liter/min, Liter/sec, m3/Hour, m3/min, mL/min, mL/sec	The unit of measured flow in HMI and Display home pages.
Flow Valve Dot Points No.	One/Two/Three /without dot point	This parameter is multiplied to the initially measured flow rate to calculate the real flow rate.
Flow Direction	Positive	Flow measurement in the positive direction (same as the arrow on the transmitter body).
	Negative	Flow measurement in the negative direction (opposite to the arrow on the transmitter body).
	Bi Directional	Flow measurement in both positive and negative directions.
Flow Damping Time	0.1-20.0	The time that the measured flow is averaged out
Flow Simulation	Flow Simulate ON	Simulates a non-real flow rate for diagnostics purposes. (while this button is in this state, an enter parameter box is shown in the right side of the page and the operator can simulate the flow rate as the entered value)
	Flow Simulate OFF	In this state the flowmeter returns the real measured flow as the flow rate.

① Using sub menu “4-1-HMI Setting” at the bottom of this page one can access the general setting for HMI unit.

5.6 Batch filling

Reinmeer Remfil flowmeters can directly control the filling valve without need for any other controller using its "Batch Filling" option. This option can be enabled by a digital input and Remfil flowmeter provides a digital output to open the filling valve.

The Batch Filling process can be configured using its corresponding parameters available either in HMI unit or via the Modbus serial communication.

To use the Batch Filling option follow the instruction bellow:

1. Set the digital input mode for one of the digital inputs to "Batch Filling Start" (see section 5.2.2)
2. Set one of the digital outputs mode to "Batch Filling Valve with DI" (see section 5.2.3)
3. Do the setting of batch filling (see section 5.6.1)

See Section 4.3 for hardware configuration.

5.6.1 Batch Filling Setting Page in HMI unit

Follow the bellow path to access the setting of “*Batch filling*”:

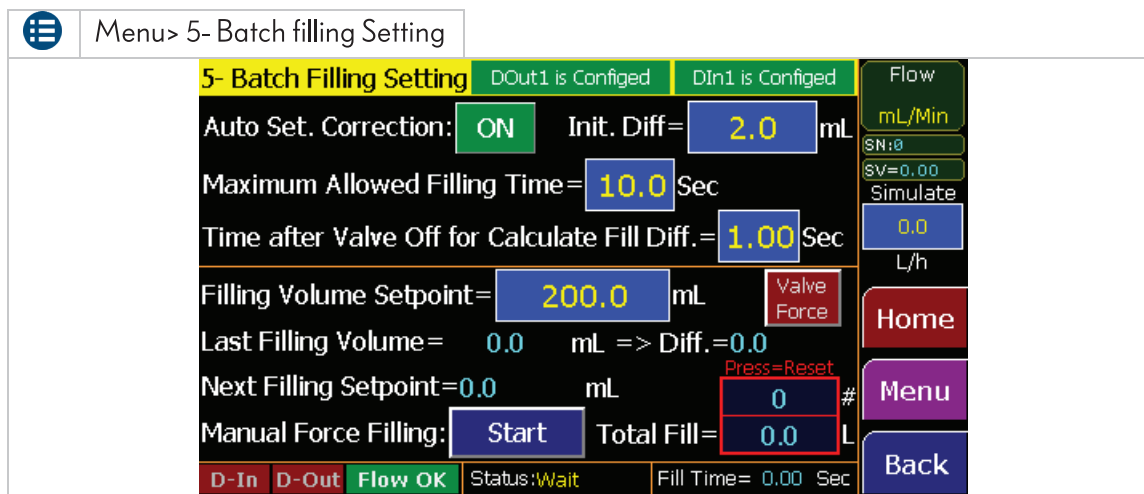

Figure 5-9- Batch Filling Setting page

Parameter	Explanation
Auto Set. Correction	By enabling this option Remfil flowmeter compare the previous “ <i>Next Filling Setpoint</i> ” with “ <i>Last Filling Volume</i> ” and if there was any error it corrects the error in the next filling cycle automatically by changing in “ <i>Next Filling Setpoint</i> ”. (The error may have occurred because of valve’s time lag, mechanical defects of filling machine, etc.)
Init. Diff	This <u>signed value</u> is added to “ <i>Filling Volume Setpoint</i> ” at the moment of sensor turning-ON or changing of filling parameters, and result would be taken as the initial “ <i>Next Filling Setpoint</i> ”.
Maximum Allowed Filling Time	The maximum time duration that the filler is allowed to reach the “ <i>Next Filling Setpoint</i> ”. (this parameter must be large enough to prevent the “ <i>Low Flow Alarm</i> ” in normal conditions, so after filling was started, if “ <i>Fill Time</i> ” reaches this parameter, it means that the flow rate is too low or the filler tank is empty. in this situation the flowmeter terminates the filling cycle and turns “ <i>Low Flow Alarm</i> ” ON).
Time after Valve Off for calculate Fill Diff	The time duration that is required to reach the zero flow rate after filler valve is turned OFF by the flowmeter. (During this time filling “ <i>Status</i> ” is “ <i>OFF-Filling</i> ”)
Valve Force	This button forces filling valve ON for CIP or test (by touching this button again it returns to its previous state)
Filling Volume Setpoint	Desired filling volume.
Last Filling Volume	Volume of the last filled container.
Diff.	Difference between the previous “ <i>Next Filling Setpoint</i> ” and the “ <i>Last Filling Volume</i> ”
Next Filling Setpoint	If “ <i>Auto Set. Correction</i> ” was disabled this parameter is <u>constant</u> and equal to: “ <i>Next Filling Setpoint</i> ” = “ <i>Init. Diff</i> ” + “ <i>Filling Volume Setpoint</i> ”. Otherwise if “ <i>Auto Set. Correction</i> ” was enabled this parameter is equal to above equation for first filling cycle and equal to bellow equation for next filling cycles: “ <i>Next Filling Setpoint</i> ” = Previous “ <i>Next Filling Setpoint</i> ” + Last “ <i>Diff.</i> ” value.
Manual Force Filling	Starts batch filling cycle. *This command is parallel to the digital input (If digital input-1 assigned to “ <i>Batch/3State Filling Start</i> ”).
Total Fill	Number of the filling cycles (#) and the total filling volume (L). Touch and confirm to reset these values. These values remain in permanent memory even if the power was lost.
Status	Sequences of filling process. (Wait / Filling / OFF Filling).
Fill Time	Filling duration time.

5.7 Three-State Filling

Some of filling machines use “two actuators valves” in order to prevent the foam formation and increasing the measurement accuracy in such a way that in the beginning or/and end of the filling one of the actuators is ON and the other one remains OFF so the filling process is done with lower flow rate and in the middle sequence both actuators are ON and the filling occurs with a higher flow rate.

A special filling program has been devised for this kind of filling machines in Magfil flowmeters without need for any other external controller. This program has below three sequences which allows the filling operator to change the liquid volume that fills in each step:

- a) Starting
- b) Fast filling
- c) Stopping

❗ Three-State Filling is only available in Magfill flowmeters with two digital outputs (Magfil XX-2DO-8)

To use the Batch Filling option follow the instruction below:

1. Set the digital input mode for o Digital input1 to "*Batch Filling Start*" (see section 5.2.2)
2. Set Digital output1 mode to "Two Flow Fill - Low Valve" (see section 5.2.3)
3. Set Digital output2 mode to "Two Flow Fill - High Valve" (see section 5.2.3)
4. Do the setting of Three-State Filling (see section 5.7.1)

❖ See Section 4.3 for hardware configuration.

5.7.1 Three-State Filling Setting Page in HMI unit

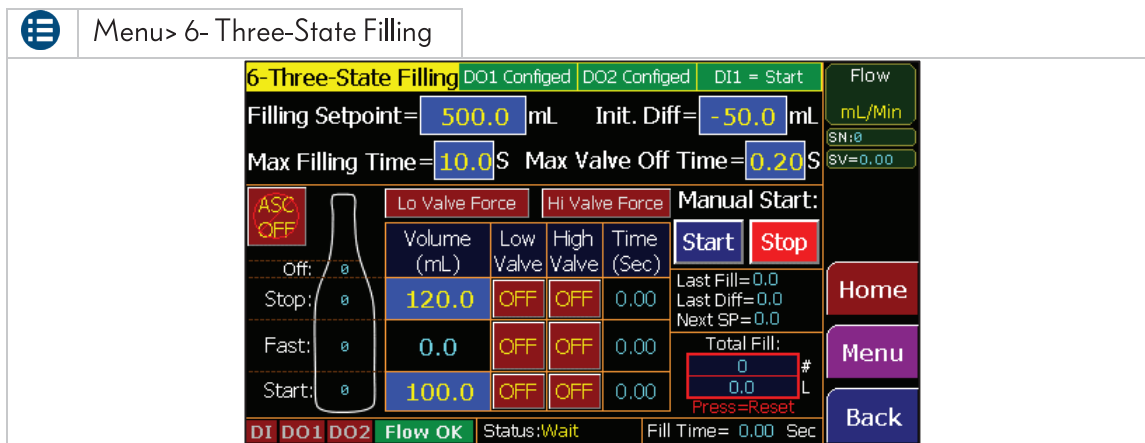

Figure 5-10- Three-State Filling Setting page

Parameter	Explanation
Filling Setpoint	Desired filling volume.
Init. Diff	At the moment of sensor turning-ON or changing of filling parameters, This <u>signed value</u> is added to "Filling Volume Setpoint" and result would be taken as the initial "Next Filling Setpoint".
Max. Filling Time	The maximum time duration that the filler is allowed to reach the "Next SP". This parameter must be large enough to prevent of "Low Flow Alarm" in normal conditions, so after filling was started, if "Fill Time" reaches this parameter, it means that the flow rate is too low or the filler tank is empty. In this situation the flowmeter terminates the filling cycle and turns "Low Flow Alarm" ON.
Max Valve Off Time	Time duration that is required to reach the zero flow rate after filler valve is turned OFF by the flowmeter. (During this time filling "Status" is "OFF-Filling")
ASC OFF/ON (Auto Setpoint Correction)	By enabling this option Magfil flowmeter compares the previous "Next SP" with "Last Fill" and if there was any error it corrects the error in the next filling cycle automatically by changing the "Next SP". (The error may have occurred because of valve's time lag, mechanical defects of filling machine, etc.)
Lo Valve Force	This button forces <i>Low filling valve</i> ON for CIP or test
Hi Valve Force	This button force <i>High filling valve</i> ON for CIP or test
Manual Start	Starts and Stops <i>Three-State filling cycle</i> manually. This command is parallel to the digital input (If digital input-1 assigned to "Batch/3State Filling Start")
Table Parameters:	
Volume(mL)	Volume of product that should be filled in each filling states. Starting and Stopping volumes is entered by the operator and the <i>Fast volume</i> is calculated by the flowmeter.
Low/High valves ON/OFF	Enables or disables Low and High valves for each filling states
Time(Sec)	Time duration for each filling states.
Last Fill	Volume of the last filled container.
Last Diff	Difference between previous "Next SP" and "Last Fill"
Next SP	If "ASC" was disabled this parameter is <u>constant</u> and equal to: $"Next SP" = "Init. Diff" + "Filling Setpoint"$ Otherwise if "ASC" was enabled this parameter is equal to above equation for first filling cycle and equal to bellow equation for next filling cycles: $"Next SP" = Previous "Next SP" + "Last Diff" value$
Total Fill	Number of the filling cycles (#) and the total filling volume (L). Touch and confirm to reset these values. These values remain in permanent memory even if the power was lost.
Status	Sequences of filling process. (Wait / Starting / Filling / Stopping / OFF Filling)
Fill Time	Filling duration time.

6 Service and maintenance

The need for regular maintenance is minimal, due to the construction with no moving parts, no mechanical adjustments and with a lining made of ceramic with high thermal and corrosion resistance.

The following rules apply:

- ① Keep the sensor and the transmitter body clean and dry.
- ① Check that the ambient temperature is not above +60°C (149°F). The transmitter body should not be too hot to keep a hand on.

Attention is drawn to the following points to ensure reliable and proper dismantling of the flowmeter:

- 1- Switch off the power source before dismantling the flowmeter
- 2- Shut off the flow through the pipeline.
- 3- Drain the pipes upstream and downstream of the flowmeter.
- 4- Support the ends of the pipes on both sides of the flowmeter when installed in a long and freely suspended section of the pipeline.
- 5- Shut off any compressed air supplies used.
- 6- Drip pans or similar receptacles should be kept ready and used to collect any residual liquids in the pipe system when dismantling the flowmeter



Precautions when removing the sensor from the process line:

- Make positively sure that the process line is not under pressure. Open a vent valve and drain valve to the atmosphere.
- Loosen the clamp cautiously, be prepared to tighten again.
- Be out of the way of any possible splash and ensure the possibility of escape.
- Use shields and protective clothing adequate for the process medium.
- Do not rely on avoidance of contact with the process medium.
- After removal of the sensor, it may be necessary to mount a blind cover for security reasons.

6.1 Connections Viton sealants

Two Viton sealants are used to seal the outlet/inlet connections in order to prevent it from leakage.

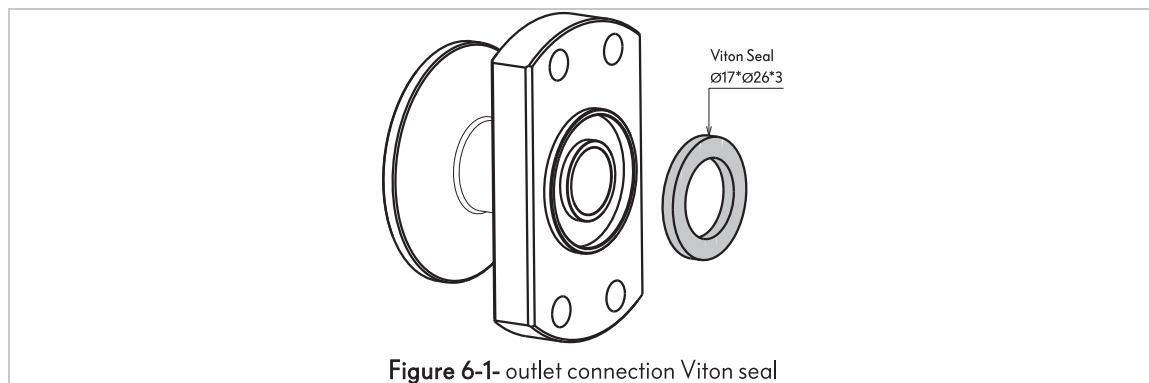

Figure 6-1- outlet connection Viton seal

- 👁️ Inspect the Viton seal of the outlet connection in a yearly basis and in the case of any leakage contact your local customer service and ask for the “Outlet Connection Viton seal” to replace it with a new one.

7 Accessories

Various accessories, which can be ordered with the device or subsequently from Reinmeer, are available for the device. Detailed information on the order code is available from your local Reinmeer sales center or on the product page of the Reinmeer website.

8 Appendix A: RS485; Modbus RTU Parameters Address

8.1 Digital Output Setting					
Parameter Name	Modbus Address		Format	Type	Range
	Dec	Hex			
1-1-0- Dig. Out Force	42	2A	Uint-16bit	R/W	0= Not Forced 1= Force to OFF 2= Force to ON
1-1-1- Dig. Out Mode	41	29	Uint-16bit	R/W	0= OFF 1= High Flow Alarm 2= Low Flow Alarm 3= Flow Out of Range 4= System is OK 5= Volume Pulse 6= Total 1 Limit 7= Total 2 Limit 8= Batch Filling
1-1-2- Dig Out Hi Limit	358	166	Uint-32bit	R/W	0.0 to 999999.0 L/h
1-1-3- Dig Out Lo Limit	360	168	Uint-32bit	R/W	0.0 to 999999.0 L/h
1-1-4- Dig Out Hystersis	43	2B	Uint-16bit	R/W	1.0 to 6550.0 L/h
1-1-5- D.O. Pulse Width	44	2C	Uint-16bit	R/W	1 to 1300 *120uSec
1-1-6-D.O. Volume/Pulse	366	16E	Uint-32bit	R/W	0.01 to 100000.00 mLiter(CC)
Digital Output Status	203.6	CB.6	Bit	R	0= D.O. is OFF 1= D.O. is ON
Digital Output Temporary Force On	244.0	F4.0	Bit	R/W	0= Not Temporary Force 1= Force to ON

8.2 Modbus Setting					
Parameter Name	Modbus Address		Format	Type	Range
	Dec	Hex			
1-2-0- Modbus Node Address	31	1F	Uint-16bit	R/W	0 to 200



8.3 Digital Inputs Setting					
Parameter Name	Modbus Address		Format	Type	Range
	Dec	Hex			
1-3-0- Dig. Input Mode	53	35	Uint-16bit	R/W	0= Disable 1= Total1 Reset 2= Total2 Reset 3= Total1&2 Reset 4= Total1 Hold 5= Total2 Hold 6= Total 1&2 Hold 7= PID Enable 8= Batch Filling Start
Dig. Input Status	203.4	CB.4	Bit	R	0= D.Input is OFF 1= D.Input is ON

8.4 Calibration					
Parameter Name	Modbus Address		Format	Type	Range
	Dec	Hex			
2-2-0- Zero Flow Volt.	16	10	Uint-16bit	R/W	0 to 65000 μ V
2-2-1- Correction Factor	374	176	Uint-32bit	R/W	0.0001 to 9999.9999
2-2-2- Corrected Flow	578	242	UInT-32bit	R	0.0 to 999999.9 L/h
1-3- Flow Damping Time	22	16	Uint-16bit	R/W	1.0 to 20.0 Sec
Flow Rate	576	240	InT-32bit	R	0 to \pm 9999999 Unit, Sign and dot-points depends on 1-0, 1-1, 1-2 Parameters.

8.5 Diagnostics					
Parameter Name	Modbus Address		Format	Type	Range
	Dec	Hex			
2-3-0- Cycle Time	233	E9	Uint-16bit	R	0.00 to 650.00 mSec
2-3-1- Coil Current High	240	F0	Uint-16bit	R	0 to 150 mA
2-3-2- Coil Current Low	241	F1	Uint-16bit	R	0 to 150 mA
2-3-3- CPU Temperature	242	F2	Uint-16bit	R	0 to 99 $^{\circ}$ C
2-3-4- Sensor SW Version	200	C8	Uint-16bit	R	--

8.6 Totalizers Setting					
Parameter Name	Modbus Address		Format	Type	Range
	Dec	Hex			
3-0- Totalizer1 Unit	57	39	Uint-16bit	R/W	0= ml (No DP) 1= Liter (1 DP) 2= m ³ (3 DP)
3-1- Total1 Reset Mode	59	3B	Uint-16bit	R/W	0= OFF 1= Setting Page 2= Digital Input 3= Sett. & Dig. In 4= Reset on Limit
3-2- Totalizer2 Unit	60	3C	Uint-16bit	R/W	0= ml (No DP) 1= Liter (1 DP) 2= m ³ (3 DP)
3-3- Total2 Reset Mode	62	3E	Uint-16bit	R/W	0= OFF 1= Setting Page 2= Digital Input 3= Sett. & Dig. In 4= Reset on Limit
Totalizer 1 Value	572	23C	Uint-32bit	R	Depended on Parameters: 3-0
Totalizer 2 Value	574	23E	Uint-32bit	R	Depended on Parameters: 3-2
Totalizer 1 Limit	370	172	Uint-32bit	R/W	Depended on Parameters: 3-0 Range : 0 to 999999999
Totalizer 2 Limit	372	174	Uint-32bit	R/W	Depended on Parameters: 3-2 Range : 0 to 999999999
Totalizer 1 Reset Bit	203.A	CB.A	Bit	W	1= Totalizer 1 Reset
Totalizer 2 Reset Bit	203.B	CB.B	Bit	W	1= Totalizer 2 Reset

8.7 Display Setting					
Parameter Name	Modbus Address		Format	Type	Range
	Dec	Hex			
4-0- Flow Unit	7	7	Uint-16bit	R/W	0= ml/Min 1= ml/Sec 2= Liter/Hour 3= Liter/Min 4= Liter/Sec 5= m3/Hour 6= m3/Min
4-1- Flow Dot Points	8	8	Uint-16bit	R/W	0 to 3
4-2- Flow Direction	9	9	Uint-16bit	R/W	0= Positive 1= Negative 2= Bi-Directional
4-3- Flow Damping Time	22	16	Uint-16bit	R/W	1.0 to 20.0 Sec
4-4- Flow Simulation	203.9	CB.9	Bit	R/W	0= Simulation OFF 1= Simulation ON
4-5- Simulated Flow	580	244	Int-32bit	R/W	0.0 to ± 999999.9 L/h

8.8 Batch Filling					
Parameter Name	Modbus Address		Format	Type	Range
	Dec	Hex			
5-0- Auto Setpoint Correction	5.0	5.0	Bit	R/W	0= Auto Correction OFF 1= Auto Correction ON
5-1- Initial Valve off Difference	402	192	Int-32bit	R/W	-9999.9 to 9999.9 mL
5-2- Max Filling Time	400	190	Uint-32bit	R/W	0.0 to 99.9 Sec *
5-3- Valve Off Time	66	42	Uint-16bit	R/W	0.0 to 7.8 Sec *
5-4- Filling Volume Setpoint	398	18E	Uint-32bit	R/W	0.1 to 999999.9 mL
5-5- Last Filling Volume	592	250	Uint-32bit	R	0.0 to 999999.9 mL
5-6- Last Filling Difference	594	252	Int-32bit	R	0.0 to \pm 999999.9 mL
5-7- Next Filling Setpoint	596	254	Uint-32bit	R	0.0 to 999999.9 mL
5-8- Filling Counter	602	25A	Uint-32bit	R	0 to 9999999
5-9- Total Filling Volume	598	256	Uint-32bit	R	0.0 to 999999.9 L
5-10- Last Filling Time	600	258	Uint-32bit	R	0.00 to 999.99 Sec *
5-11- Filling Status	238	EE	Uint-16bit	R	0=Wait for Start 1=Filling 2=Off Filling
Manual Force Filling	245.0	F5.0	Bit	R/W	0= Not Force 1= Filling Force
Fill Totalizer & Counter Reset	246.0	F6.0	Bit	R/W	0= Not Reset 1= Reset Fill Totalizer
High Filling Flow	227.7	E3.7	Bit	R	0=No Hi. Flow Alarm 1=Hi. Flow Alarm On
Low Filling Flow	227.6	E3.6	Bit	R	0=No Low Flow Alarm 1=Low Flow Alarm On
<p>The data read from or write on these addresses must be divided or multiplied by 83.3 respectively.</p> <ul style="list-style-type: none">  Eg1: if value 5247 is read as “Last Filling Time” the exact value of the parameter would be 6.3sec (5247/83.3=63).  Eg2: if 2.5sec has to be written as “Valve Off Time” you must input 2082 (25*83.3=2082) on the corresponding field. 					

8.3 Digital Inputs Setting					
Parameter Name	Modbus Address		Format	Type	Range
	Dec	Hex			
1-3-0- Dig. Input Mode	53	35	Uint-16bit	R/W	0= Disable 1= Total1 Reset 2= Total2 Reset 3= Total1&2 Reset 4= Total1 Hold 5= Total2 Hold 6= Total 1&2 Hold 7= PID Enable 8= Batch Filling Start
Dig. Input Status	203.4	CB.4	Bit	R	0= D.Input is OFF 1= D.Input is ON

8.4 Calibration					
Parameter Name	Modbus Address		Format	Type	Range
	Dec	Hex			
2-2-0- Zero Flow Volt.	16	10	Uint-16bit	R/W	0 to 65000 μ V
2-2-1- Correction Factor	374	176	Uint-32bit	R/W	0.0001 to 9999.9999
2-2-2- Corrected Flow	578	242	UInt-32bit	R	0.0 to 999999.9 L/h
1-3- Flow Damping Time	22	16	Uint-16bit	R/W	1.0 to 20.0 Sec
Flow Rate	576	240	Int-32bit	R	0 to \pm 9999999 Unit, Sign and dot-points depends on 1-0, 1-1, 1-2 Parameters.

8.5 Diagnostics					
Parameter Name	Modbus Address		Format	Type	Range
	Dec	Hex			
2-3-0- Cycle Time	233	E9	Uint-16bit	R	0.00 to 650.00 mSec
2-3-1- Coil Current High	240	F0	Uint-16bit	R	0 to 150 mA
2-3-2- Coil Current Low	241	F1	Uint-16bit	R	0 to 150 mA
2-3-3- CPU Temperature	242	F2	Uint-16bit	R	0 to 99 $^{\circ}$ C
2-3-4- Sensor SW Version	200	C8	Uint-16bit	R	--

8.6 Totalizers Setting					
Parameter Name	Modbus Address		Format	Type	Range
	Dec	Hex			
3-0- Totalizer1 Unit	57	39	Uint-16bit	R/W	0= ml (No DP) 1= Liter (1 DP) 2= m ³ (3 DP)
3-1- Total1 Reset Mode	59	3B	Uint-16bit	R/W	0= OFF 1= Setting Page 2= Digital Input 3= Sett. & Dig. In 4= Reset on Limit
3-2- Totalizer2 Unit	60	3C	Uint-16bit	R/W	0= ml (No DP) 1= Liter (1 DP) 2= m ³ (3 DP)
3-3- Total2 Reset Mode	62	3E	Uint-16bit	R/W	0= OFF 1= Setting Page 2= Digital Input 3= Sett. & Dig. In 4= Reset on Limit
Totalizer 1 Value	572	23C	Uint-32bit	R	Depended on Parameters: 3-0
Totalizer 2 Value	574	23E	Uint-32bit	R	Depended on Parameters: 3-2
Totalizer 1 Limit	370	172	Uint-32bit	R/W	Depended on Parameters: 3-0 Range : 0 to 999999999
Totalizer 2 Limit	372	174	Uint-32bit	R/W	Depended on Parameters: 3-2 Range : 0 to 999999999
Totalizer 1 Reset Bit	203.A	CB.A	Bit	W	1= Totalizer 1 Reset
Totalizer 2 Reset Bit	203.B	CB.B	Bit	W	1= Totalizer 2 Reset

8.7 Display Setting					
Parameter Name	Modbus Address		Format	Type	Range
	Dec	Hex			
4-0- Flow Unit	7	7	Uint-16bit	R/W	0= ml/Min 1= ml/Sec 2= Liter/Hour 3= Liter/Min 4= Liter/Sec 5= m3/Hour 6= m3/Min
4-1- Flow Dot Points	8	8	Uint-16bit	R/W	0 to 3
4-2- Flow Direction	9	9	Uint-16bit	R/W	0= Positive 1= Negative 2= Bi-Directional
4-3- Flow Damping Time	22	16	Uint-16bit	R/W	1.0 to 20.0 Sec
4-4- Flow Simulation	203.9	CB.9	Bit	R/W	0= Simulation OFF 1= Simulation ON
4-5- Simulated Flow	580	244	Int-32bit	R/W	0.0 to ± 999999.9 L/h

8.8 Batch Filling					
Parameter Name	Modbus Address		Format	Type	Range
	Dec	Hex			
5-0- Auto Setpoint Correction	5.0	5.0	Bit	R/W	0= Auto Correction OFF 1= Auto Correction ON
5-1- Initial Valve off Difference	402	192	Int-32bit	R/W	-9999.9 to 9999.9 mL
5-2- Max Filling Time	400	190	Uint-32bit	R/W	0.0 to 99.9 Sec *
5-3- Valve Off Time	66	42	Uint-16bit	R/W	0.0 to 7.8 Sec *
5-4- Filling Volume Setpoint	398	18E	Uint-32bit	R/W	0.1 to 999999.9 mL
5-5- Last Filling Volume	592	250	Uint-32bit	R	0.0 to 999999.9 mL
5-6- Last Filling Difference	594	252	Int-32bit	R	0.0 to ±999999.9 mL
5-7- Next Filling Setpoint	596	254	Uint-32bit	R	0.0 to 999999.9 mL
5-8- Filling Counter	602	25A	Uint-32bit	R	0 to 9999999
5-9- Total Filling Volume	598	256	Uint-32bit	R	0.0 to 999999.9 L
5-10- Last Filling Time	600	258	Uint-32bit	R	0.00 to 999.99 Sec *
5-11- Filling Status	238	EE	Uint-16bit	R	0=Wait for Start 1=Filling 2=Off Filling
Manual Force Filling	245.0	F5.0	Bit	R/W	0= Not Force 1= Filling Force
Fill Totalizer & Counter Reset	246.0	F6.0	Bit	R/W	0= Not Reset 1= Reset Fill Totalizer
High Filling Flow	227.7	E3.7	Bit	R	0=No Hi. Flow Alarm 1=Hi. Flow Alarm On
Low Filling Flow	227.6	E3.6	Bit	R	0=No Low Flow Alarm 1=Low Flow Alarm On
<p>The data read from or write on these addresses must be divided or multiplied by 83.3 respectively.</p> <p>i Eg1: if value 5247 is read as “Last Filling Time” the exact value of the parameter would be 6.3sec (5247/83.3=63).</p> <p>i Eg2: if 2.5sec has to be written as “Valve Off Time” you must input 2082 (25*83.3=2082) on the corresponding field.</p>					

8.9 Alarm List & Addresses(Bit)				
Name	Address		Type	Solution
	Dec	Hex		
Digital Output 1 Pulse Overlap	227.0	E3.0	R	Increase "1-1-6-D.O Volume/Pulse" and/or Decrease "1-1-5- D.O Pulse Width"
Micro Controller HSE Error	227.2	E3.2	R	Contact to Control System Co.
Test Timer Timeout!!!	227.3	E3.3	R	Contact to Control System Co.
Totalizer 1 Reset Inhibited	227.4	E3.4	R	Change "3-1-Total1 Reset Mod" Parameter
Totalizer 2 Reset Inhibited	227.5	E3.5	R	Change "3-3-Total2 Reset Mod" Parameter
Low Filling Flow Rate	227.6	E3.6	R	Increase Pipe Flow and/or Increase "5-2- Max Filling Time"
High Filling Flow Rate	227.7	E3.7	R	Decrease Pipe Flow
CPU Low Temperature	227.8	E3.8	R	Call Local service center
CPU High Temperature	227.9	E3.9	R	Call Local service center