

RM-AC800 – Advanced Control Devices

Description

The AC800 series are fully modular industrial devices designed for measuring and controlling process variables such as temperature, pressure, speed, level, humidity, current, voltage, and resistance. They are suitable for On/Off and PID control applications in industries such as Food, Plastic, Iron-Steel, Chemical, Metallurgy, Cement, Ceramics, Petro-Chemistry, Refineries, and Glass.



General Features

- Display: LCD screen with 3 sets of 4-digit numerical displays.
- Indicators: Dedicated LED indicators for relay states.
- Control Interface: 4 capacitive touch keys.
- Control Types: PID Heating/Cooling, On/Off, P, PI, PD, and Floating Valve Control (without feedback)
- Advanced Functions: Auto-Tuning, Self-Tune, and Bumpless Transfer.
- Communication: Standard MODBUS RTU via RS485 unit.

Input and Output Modules

- Universal Sensor Input (S1): Supports TC, RTD, mA, mV, and V.
- Auxiliary Analog Input (S2): 0/4-20mA.
- Potentiometer Input (S3): Supports 100 to 15,000 Ω .
- Digital Inputs: 3 logic inputs (15V).
- Analog Outputs (O1, O2): 2 outputs supporting 0/4-20mA or 0/2-10V.
- Relay Outputs (R1-R4): 4 relay or logic (24V) outputs.
- Transmitter Supply (TX): 1 isolated 24VDC (30mA) output.

Device Dimensions

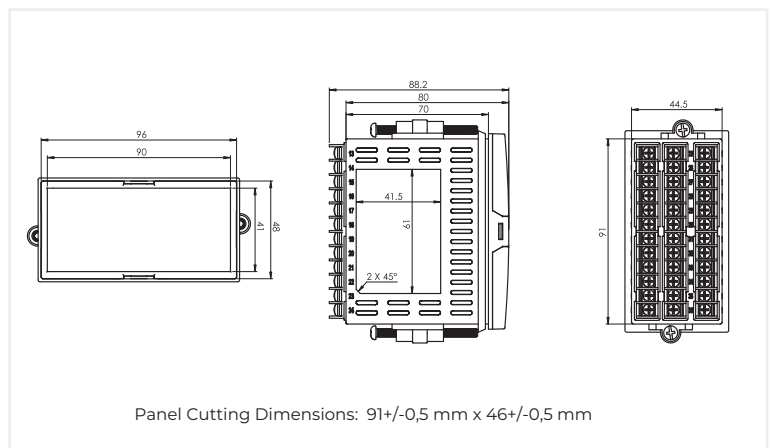

Applications

Food, Plastic, Iron & Steel, Chemical, Metallurgy, Cement, Ceramic, Petrochemical, Refineries, Glass, and other industrial sectors.

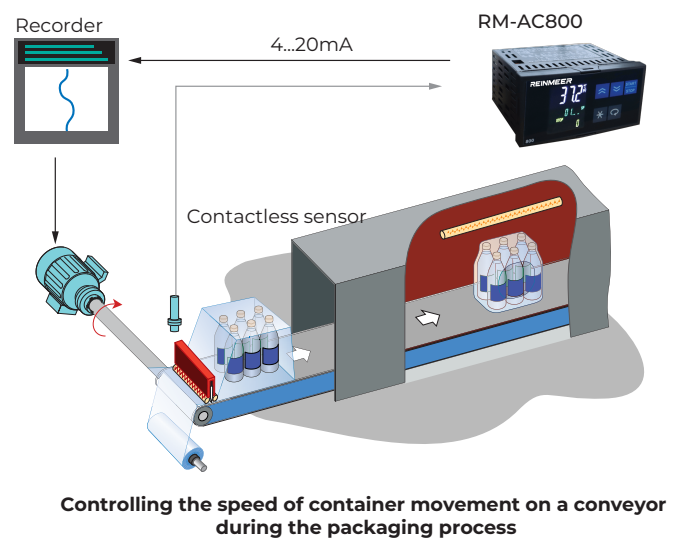
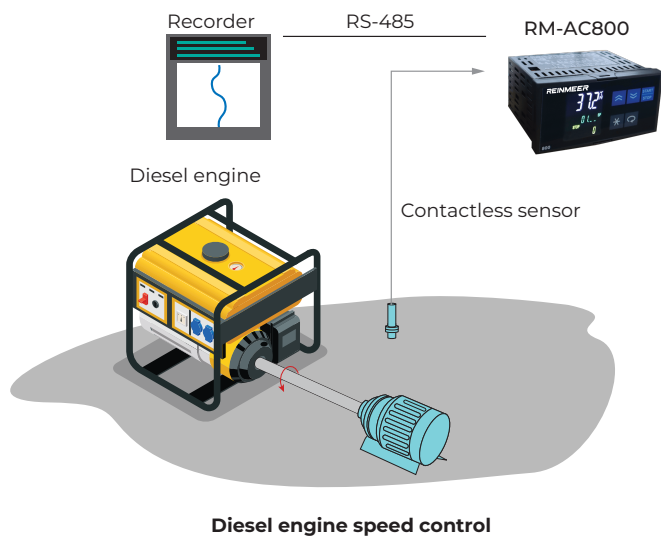

Technical Specifications

Supply Voltage (PS)	100-240V AC/DC (+10% / -15%) or 24V AC/DC (+10% / -20%).
Power Consumption	6W / 10VA.
Universal Sensor Input (S1)	Thermocouple = B, E, J, K, L, N, R, S, T, U Two-Wire Transmitter = 4-20mA Resistance Thermometer = Pt-100 Current = 0/4-20mA Voltage = 0-50mV, 0/2-10V
Auxiliary Analog Input (S2)	0/4-20mA
Potentiometer Input (S3)	100-15000Ω
Transmitter Supply (TX)	24Vdc (Isc=30mA)
Analog Input Impedances	Thermocouple, mV: 10MΩ Current: 10Ω Voltage: 1MΩ
Analog Outputs (O1, O2)	Current: 0/4-20mA (RL ≥ 500Ω) Voltage: 0/2-10V (RL ≥ 1MΩ)
Relay Outputs (R1, R2, R3, R4)	Contact (R1, R2, R3, R4) : 250VAC 10A Logic Output = 24Vdc 20mA
Contact Life	No load: 10,000,000 operations 250V 10A resistive load: 1,000,000 operations
Other	Memory: 100 years / 100,000 rewrites Accuracy: ± 0.2% Sampling time: 100 ms Operating temperature: -10...+55°C Storage temperature: -20...+65°C
Protection class:	Front panel IP54 / Rear panel IP20
Mechanical Specifications	Width: 96 mm Height: 48 mm Depth: 78.2 mm Weight: 430 gr
Panel Cut-out Dimensions	92 +/- 0,5 mm x 45,5 +/- 0,5 mm

Electrical Wiring Diagram

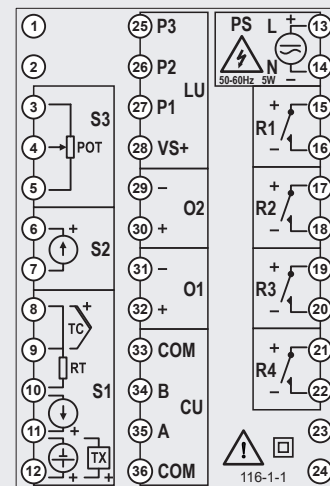

Module	Description
S1	Universal sensor input module (The sensor used for process value measurement is connected to the terminals with the appropriate symbol on this module).
S2	0/4-20mA auxiliary analog input module (The function of this module can be selected via the device).
S3	100-1500Ω Potentiometer input or
LU	Logic input module.
CU	RS485 MODBUS RTU module.
O1, O2	Analog output modules (The content of this module is determined by the product code, while its functions can be selected via the device).
R1, R2, R3, R4	RS485 communication module. (The contents of this module are determined by the product code, and its functions can be selected via the device).
PS	Power supply input. (The supply voltage is determined by the product code).