

# REINMEER

www.reinmeer.com



## Coriolis mass flowmeter L-Cryogenic Series **RM-CMASS040LU LNG**

[Data sheet](#)

Advanced Coriolis Technology for  
Extreme LNG Environments

# Coriolis Mass Flowmeter

## RM-CMASS040LU LNG

# REINMEER

RM-CMASS040LU LNG

### Application Areas

LNG Receiving Terminals  
LNG Refueling Stations  
Liquefaction Plants  
Cryogenic Storage Systems  
Chemical Processing  
Marine & Offshore

### Features

- Cryogenic Precision: Optimized for ultra-low temperature media down to  $-200^{\circ}\text{C}$ .
- Direct Mass Measurement: Provides accurate mass flow without needing temperature or pressure compensation.
- High Flow Capacity: Supports a maximum flow rate of 450 kg/min (DN40 diameter).
- Superior Accuracy: Delivers  $\pm 0.15\%$  accuracy with 0.075% repeatability for critical trade.
- Advanced DSP Technology: Digital signal processing effectively suppresses vibration and signal interference.
- Explosion-Proof Safety: Certified with Ex d ib IIC T6 Gb for hazardous environment operations.
- Robust & Maintenance-Free: Features a U-shaped tube design with no moving parts to ensure long-term durability.
- Versatile Connectivity: Supports Modbus RTU/RS-485, HART, and 4-20mA output signals.

### Description

The CMASS040LU LNG Coriolis Mass Flowmeter, offered under the Reinmeer brand philosophy of precision and reliability, represents a pinnacle in cryogenic flow measurement technology. Engineered to handle the extreme challenges of Liquefied Natural Gas (LNG) applications, this device ensures high-accuracy performance even at temperatures as low as  $-200^{\circ}\text{C}$ . By integrating advanced digital signal processing with a robust U-shaped tube design, Reinmeer provides a solution that eliminates the complexities of temperature and pressure compensation, delivering direct mass flow data with unmatched stability.

Reinmeer focuses on empowering industrial operations through innovation and durability. The CMASS040LU model is specifically crafted for high-flow environments, featuring a DN40 caliber that supports rates up to 450 kg/min. With a commitment to safety and international standards, Reinmeer ensures that every unit meets rigorous explosion-proof certifications, making it the preferred choice for global LNG terminals, bunkering stations, and large-scale cryogenic storage facilities where custody transfer accuracy is paramount.

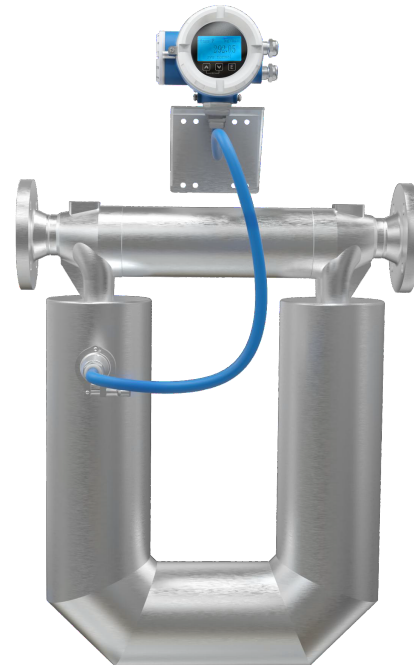

### Diameters

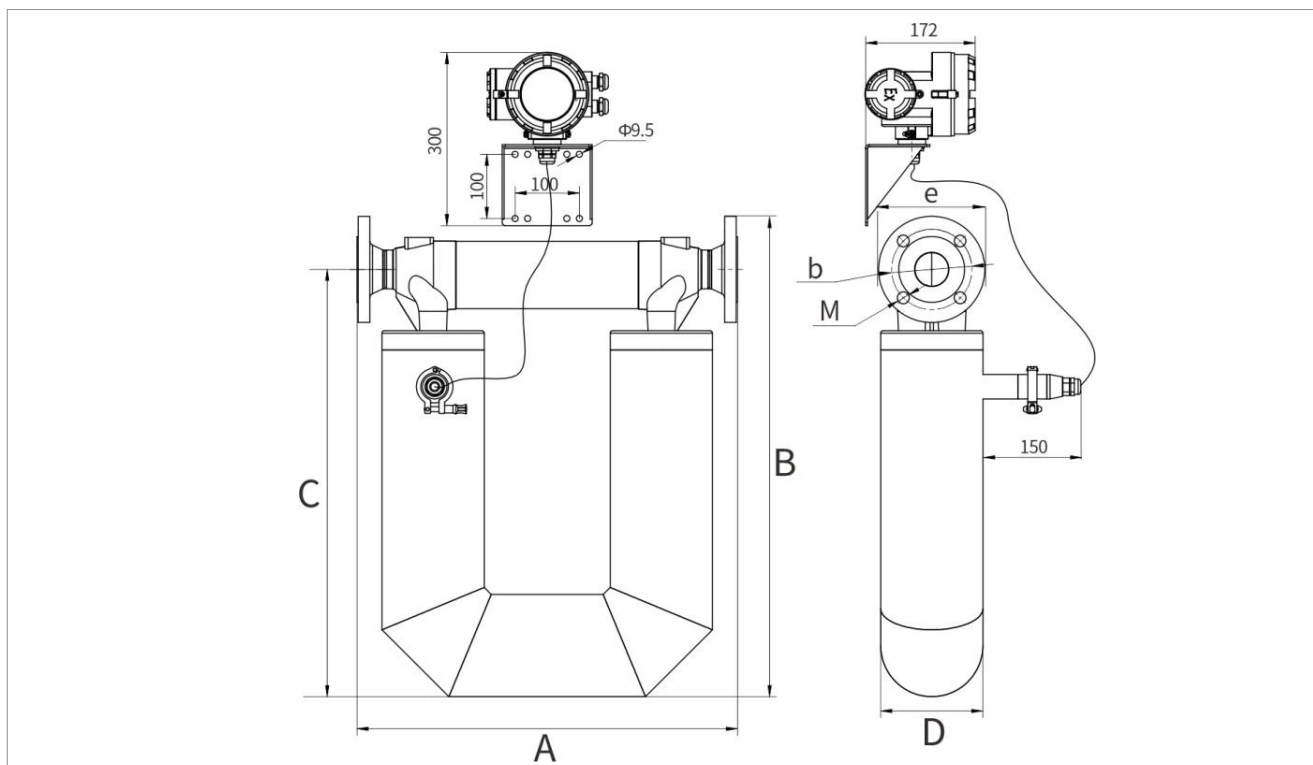

### Model and diameter

MODEL	A	B	C	D	e	b	F	M
RM-CMASS040	560	699	324	$\Phi 140$	$\Phi 150$	$\Phi 110$	$\Phi 18$	HG/T 20592 DN40 PN40 Flange
RM-CMASS050	592	747	665	$\Phi 159$	$\Phi 165$	$\Phi 125$	4- $\Phi 16$	HG/T 20592 DN50 PN40 Flange
RM-CMASS080	763	950	850	$\Phi 219$	$\Phi 200$	$\Phi 160$	8- $\Phi 18$	HG/T 20592 DN80 PN40 Flange

### Typical Application Scenarios

- Unloading measurement and tank turnover at LNG receiving terminals
- Large-scale vehicle or ship bunkering at LNG refueling stations
- Custody transfer and trade measurement at liquefaction plants
- Leak detection and inventory management in cryogenic storage tanks
- Flow control of cryogenic media (e.g., liquid nitrogen, liquid oxygen) in chemical processes

**Transmitter Specifications**

<b>Certification: Transmitter &amp; Sensor Assembly</b>	CCS Certification, CPA, Explosion proof certificate(ex)
<b>Power Supply</b>	220VAC/24VDC Self-adaption
<b>Output signal</b>	Hart,4 to 20mA current loop active, Modbus RTU/RS-485, Pulse active
<b>Display;Operate</b>	3-line backlight; Touch key control
<b>Protection grade</b>	IP66,IP67
<b>Housing material</b>	304 stainless steel, ZL401 (Transmitter)
<b>Electrical connection</b>	1/2 NPT,M20*1.5
<b>Measuring Tube Material; Wetted Parts Surface Finish</b>	316L (default), titanium/Ha C alloy/ tantalum (optional); polishable.
<b>Process connection</b>	Thread
<b>Accuracy</b>	±0.1%,±0.15%, ±0.2%, ±0.5 %, ±1.0%
<b>Transmitter software</b>	CLS100 (default), optional CLS200, CLS300
<b>&gt;&gt;Other certifications</b>	Explosion proof certificate, SIL, CCS, 3-A, EAC

Steady Flow, Massive Measurement, Cryogenic Precision – Coriolis Mass Flow Meter Optimized for High-Flow LNG Applications.

In LNG receiving terminals, storage and transportation hubs, and large-scale bunkering systems, achieving high-precision mass flow measurement under cryogenic and high-flow conditions is crucial for ensuring operational efficiency and trade fairness.

Coriolis' DN40 cryogenic Coriolis mass flow meter, with its ultra-low temperature adaptability and high flow rate stability, is a reliable choice for the LNG industry.

**Core Operational Challenges Addressed**

**1. Stable Measurement in Cryogenic Environments**

**Challenge:** LNG's extremely low temperature ( $\leq -162^{\circ}\text{C}$ ) can cause material embrittlement, signal drift, and measurement inaccuracies in traditional flow meters.

**Solution:** Designed specifically for cryogenic environments, both the sensor and transmitter offer ultra-low temperature resistance, ensuring long-term stable operation within a range of  $-200^{\circ}\text{C}$  to  $+150^{\circ}\text{C}$ .

**2. Maintaining Accuracy Under High Flow Rates**

**Challenge:** High-flow impacts can cause pipeline vibration and signal interference, affecting measurement repeatability and accuracy.

**Solution:** Utilizing a U-shaped tube structure combined with digital signal processing (DSP) technology, it effectively suppresses fluid vibration interference. With a turndown ratio of 100:1 and a maximum flow rate of 450 kg/min, it maintains an accuracy of  $\pm 0.15\%$ .



### 3. Direct Mass Output Without Temperature or Pressure Compensation

**Challenge:** Frequent changes in density and temperature during LNG vaporization require constant compensation for volumetric flow meters, leading to complex systems and cumulative errors.

**Solution:** The Coriolis principle directly measures mass flow, unaffected by changes in medium properties, providing stable and reliable output while simplifying system structure.

### 4. High Pressure and Explosion-Proof Safety Requirements

**Challenge:** LNG processes often involve high-pressure conditions, requiring compliance with explosion-proof and pressure vessel standards.

**Solution:** With a maximum working pressure of 4MPa and Ex d ib IIC T6 Gb explosion-proof certification, it ensures safe operation.

### Core Product Advantages

**Cryogenic Expertise:** Optimized for cryogenic media such as LNG, liquid nitrogen, and liquid oxygen, with materials and processes tailored for low-temperature environments.

**High Accuracy for High Flow Rates:** DN40 caliber supports a maximum flow rate of 450 kg/min, with  $\pm 0.15\%$  accuracy and 0.075% repeatability.

**Direct Mass Measurement:** No temperature or pressure compensation required; outputs multiple parameters including mass flow, density, and temperature.

**Robust Structure with No Moving Parts:** U-shaped tube design ensures no wear, maintenance-free operation, and suitability for long-term use.

**Explosion-Proof Safety Certification:** Complies with international standards such as ATEX and IECEx, making it suitable for hazardous areas.

# Contact us

---

## **Address :**

Reinmeer Factory Address  
Eutiner Str.12,22143  
Hamburg, Germany  
[reinmeer@reinmeer.com](mailto:reinmeer@reinmeer.com)