

REINMEER

www.reinmeer.com



Turbine Flowmeter RM-HTD

[Data sheet](#)

4-20 mA or 0-10 V options
inexpensive, practical, leakproof housing



Turbine Flowmeter

MODEL RM-HTD

REINMEER

Data sheet Model RM-HTD

Application Areas

Water & Salt Water Networks
Food Production & Transfer Lines
Alcohol & Beverage Measurement
Chemical Fluids & Solvents
Fuel Transfer & Consumption Monitoring
Industrial Automation Integration (PLC/SCADA)

Features

- Flow Velocity Range: 0.5 – 15 m/s
- Accuracy: $\pm 1\%$ (optimal conditions)
- Repeatability: $\pm 1.5\%$
- Max. Temperature: 45°C (Standard models)
- Supply Voltage: 5-25 V DC / 12-24 V DC
- Output Options: Frequency (NPN), 4-20 mA, 0-10 V
- Body Materials: PP, PVC, Bronze, SS 316

Description

The RM-HTD Flow Sensor, offered by Reinmeer, is a professional measurement solution designed for industrial facilities seeking precise and cost-effective monitoring of liquid flow. Utilizing the paddlewheel principle—where moving liquid rotates an internal propeller at a speed proportional to the flow velocity—this device is specifically engineered for measuring the flow rate and total quantity of particle-free liquids. The sensor's electronic measuring cell is completely encapsulated and sealed within the outer body, ensuring total isolation from the process liquid and external environment, resulting in a highly durable, pressure-resistant, and leak-proof structure.

Thanks to its flexible installation capabilities, the RM-HTD can be safely and effectively utilized in both horizontal and vertical pipe runs. A significant advantage for reducing operating costs is the ability of a single sensor model to adapt to various pipe diameters without requiring expensive additional display hardware. Furthermore, under correct installation conditions where turbulence is minimized, the RM-HTD delivers high measurement precision and accuracy of up to 1%, ensuring outstanding reliability for critical process control applications.

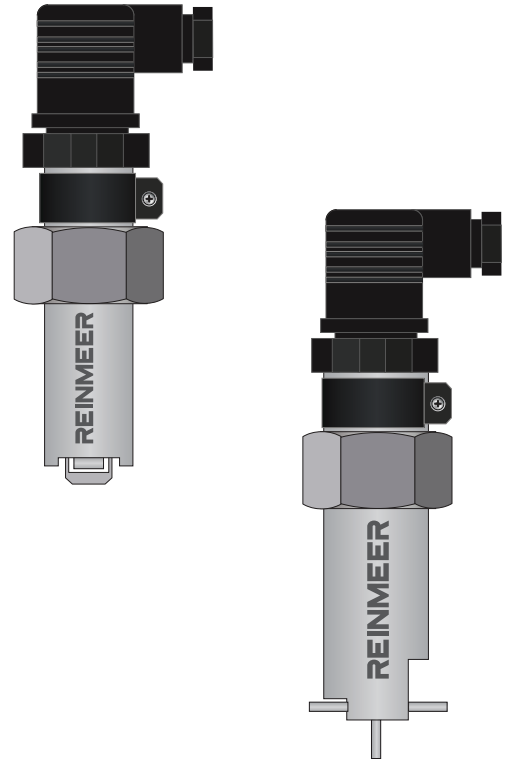

Structure

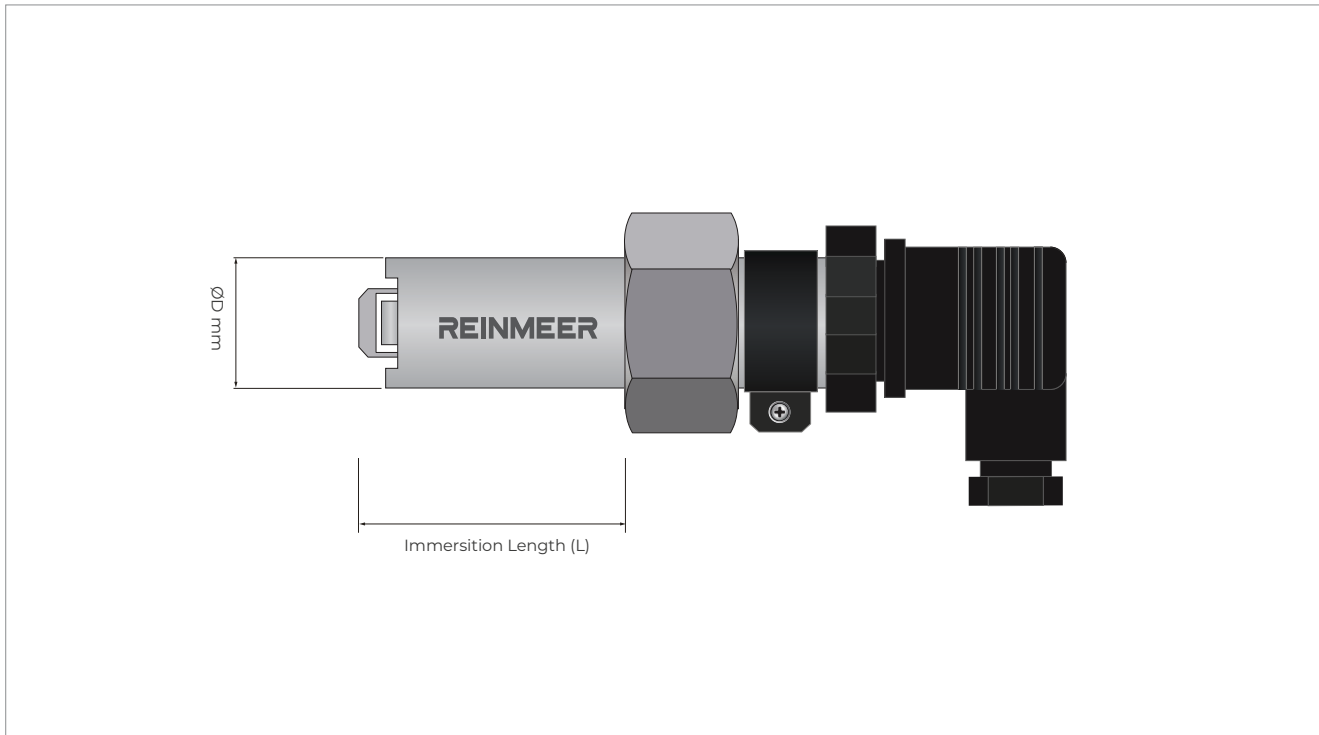

Product Features

Measurement Principle	Paddlewheel / Turbine
Fluid Type	Particle-free clean liquids (Water, chemicals, food-grade liquids)
Body Material	Stainless Steel (AISI 316 / SS316)
Applicable Pipe Diameters	All pipes between DN25 (1") and DN400 (16")
Mounting Position	Horizontal or Vertical lines (Flow direction upwards)
Measuring Range (Flow Velocity)	0.5 m/s – 15 m/s
Measurement Accuracy	±1% F.S. (Full Scale) *
Repeatability	±%1.5
Linearity	±%5
Output Options	1. Frequency (NPN Square Wave) / 2. Analog Current (4-20 mA) / 3. Analog Voltage (0-10 VDC)
Supply Voltage	5-25 V DC (for frequency output) / 12-24 V DC (for analog output)
Protection Class	IP65 / NEMA 4X (Junction box)

Turbine Flowmeter

MODEL RM-HTD



Data sheet Model RM-HTD

Structure

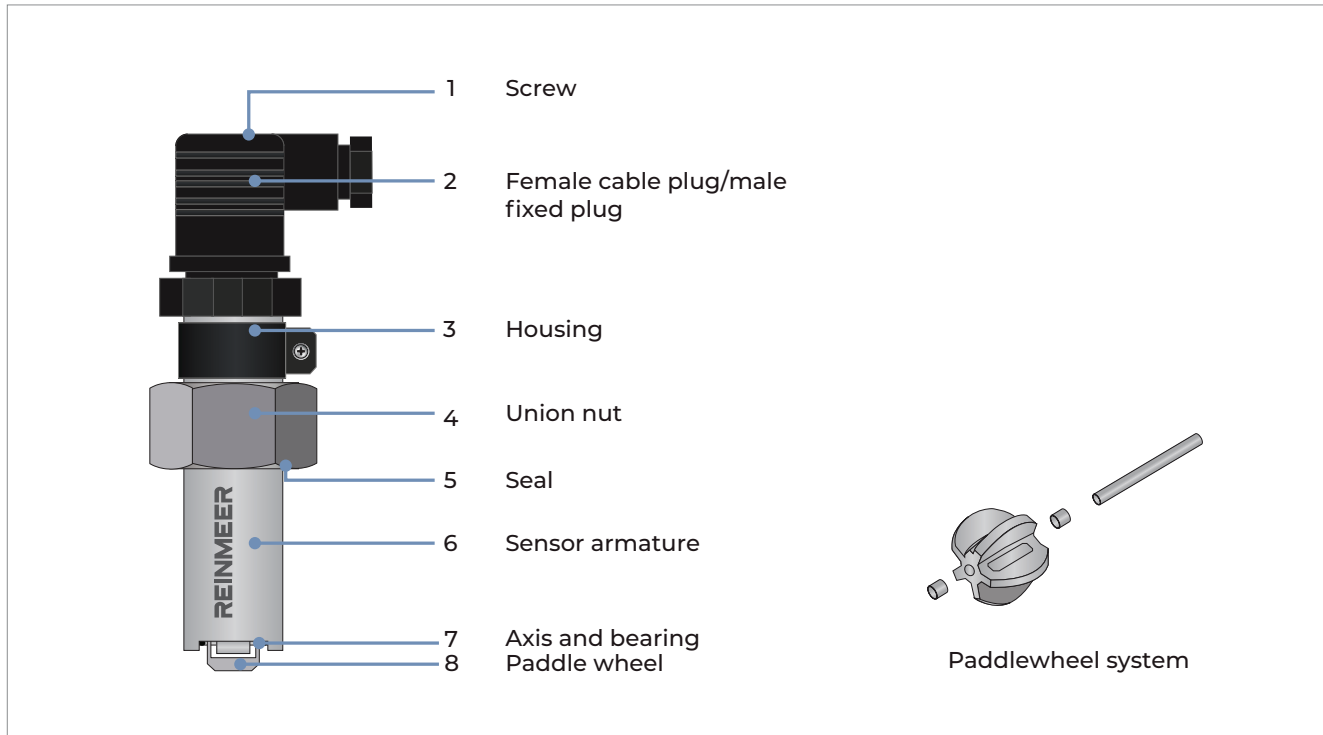

Dimensions in mm

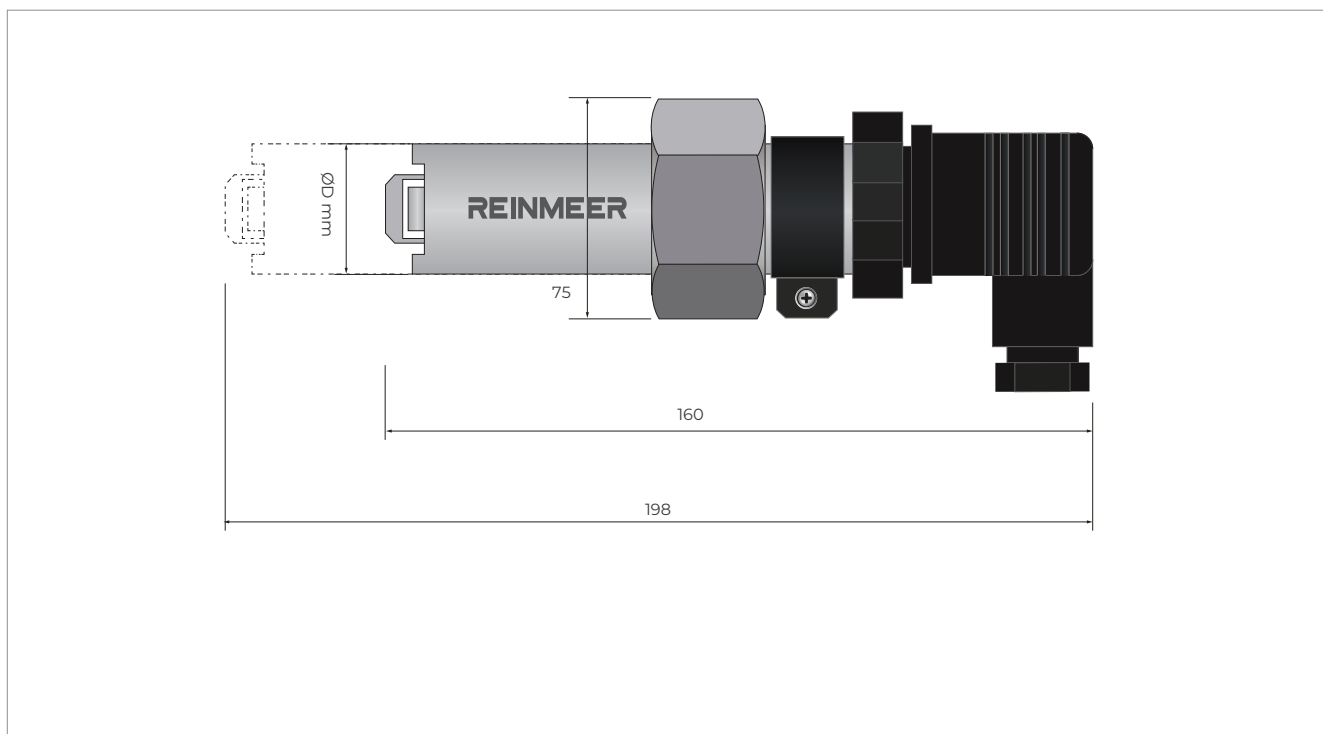

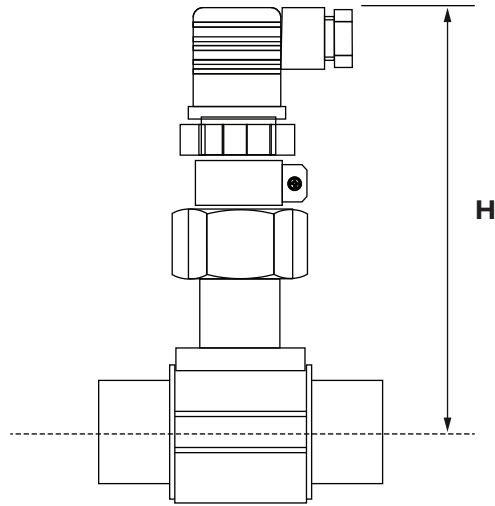

DN	H			
	T-Fitting	Saddle	Plastic spigot	Metal spigot
20	160.5	-	-	-
25	160.5	-	-	-
32	164.0	-	-	-
40	168.0	-	-	-
50	174.0	198.5	-	169.5
65	174.0	197.5	179.5	174.0
80	-	201.5	184.5	180.0
100	-	206.5	191.0	190.5
110	-	202.5	-	-
125	-	209.5	-	201.5
150	-	219.5	237.0	212.5
180	-	243.5	-	-
200	-	255.5	258.0	233.0
250	-	-	276.0	293.0
300	-	-	287.5	312.5
350	-	-	301.0	324.5
400	-	-	315.5	-

Turbine Flowmeter MODEL RM-HTD

Installation Guidelines

Different pipe configurations and obstacles in the flow line such as valves, elbows, pipe bends and strainers create variations on the flow profile.

The six most common installation configurations are shown to help in selecting the best location in the pipe-line for paddlewheel flow sensor.

For more information, please refer to EN ISO 5167-1.

Always maximize distance between flow sensors and pumps.

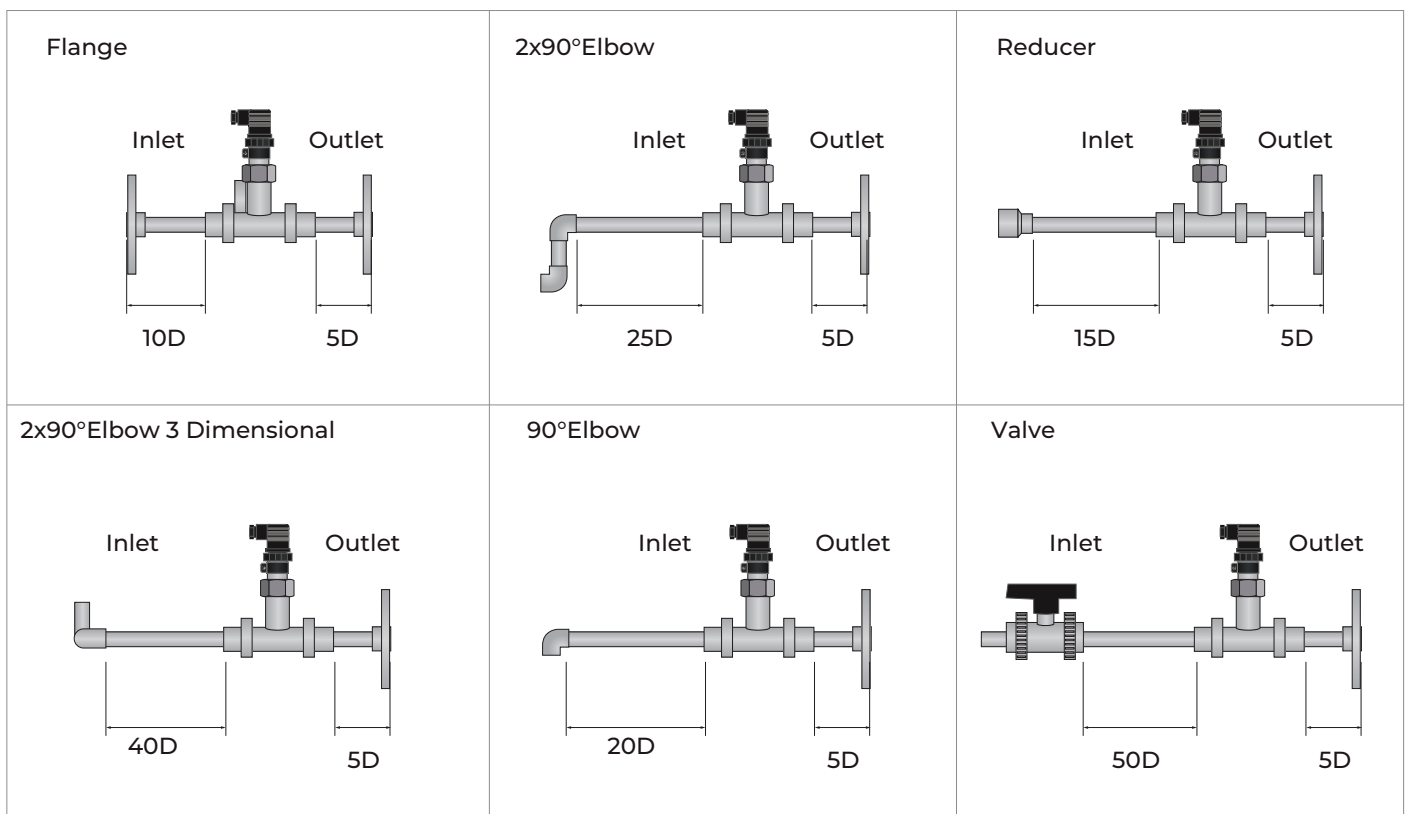

Mounting Positions

Make sure the pipeline is always full.

Horizontal pipe runs:

Fig. 1: Installation with no sediments present

Fig. 2: Installation with no air bubbles present

Fig. 3: Installation if sediments or air bubbles may be present

Vertical pipe runs:

Install sensor in any orientation.

Upward flow is preferred to ensure full pipe.

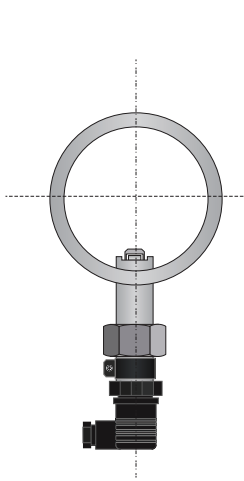

Fig1

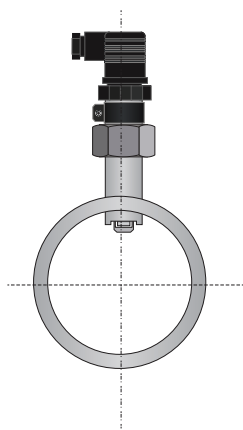

Fig2

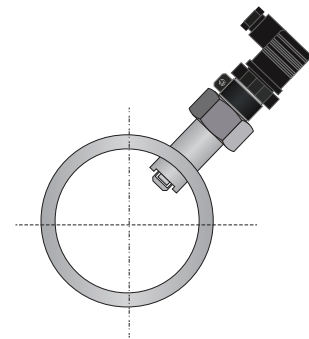

Fig3