

# REINMEER

www.reinmeer.com



## Hydrostatic Level Transmitter RM-L01S

[Data sheet](#)

Level Transmitter  
**MODEL ETRANS L01S**



# Hydrostatic Level Transmitter

## MODEL RM L01S

REINMEER

Data sheet Model RM L01S

### Application Areas

Environmental and Water Management Sector  
Energy Sector  
Chemical and Petrochemical Industry  
Food and Beverage Sector  
Maritime and Port Facilities  
Mining Sector

### Features

- Accuracy Standard  $\pm 0.25\%$  FS or  $\pm 0.5\%$  FS
- Operating Temperature  $-20^{\circ}\text{C} \dots +70^{\circ}\text{C}$
- Liquid Measurement Range  $-10^{\circ}\text{C} \dots +80^{\circ}\text{C}$
- Operating Connection Material Stainless Steel 316L

### Description

Reinmeer Hydrostatic Level Transmitters are designed to measure liquid levels with absolute accuracy even under the most demanding industrial conditions. The measurement principle is based on hydrostatic pressure, which varies in direct proportion to the depth of the liquid. Thanks to submersible stainless steel (e.g., 316L) or special chemical-resistant housing options, they are used reliably in a wide range of applications, from wastewater treatment plants and drinking water reservoirs to chemical tanks and deep water wells. With its IP68 protection class structure and special vented cable that balances atmospheric pressure, it offers long-term and maintenance-free performance. These sensors provide indispensable reliability for critical level control, pump automation, and inventory tracking in your facilities.

These transmitters are designed to fully integrate with today's modern automation systems. With standard 4-20 mA analog output or digital (e.g., Modbus RTU) signal options, they can be easily integrated with your existing PLC, RTU, or display panels. Thanks to high precision (e.g.,  $\pm 0.25\%$  FS) and fast response times, tank filling and emptying cycles are monitored and controlled instantaneously, minimizing the risks of overfilling or dry running. Reinmeer's level transmitters are not just measurement devices, but a long-lasting and economical investment that enhances your operational efficiency and facility safety.



### Structure

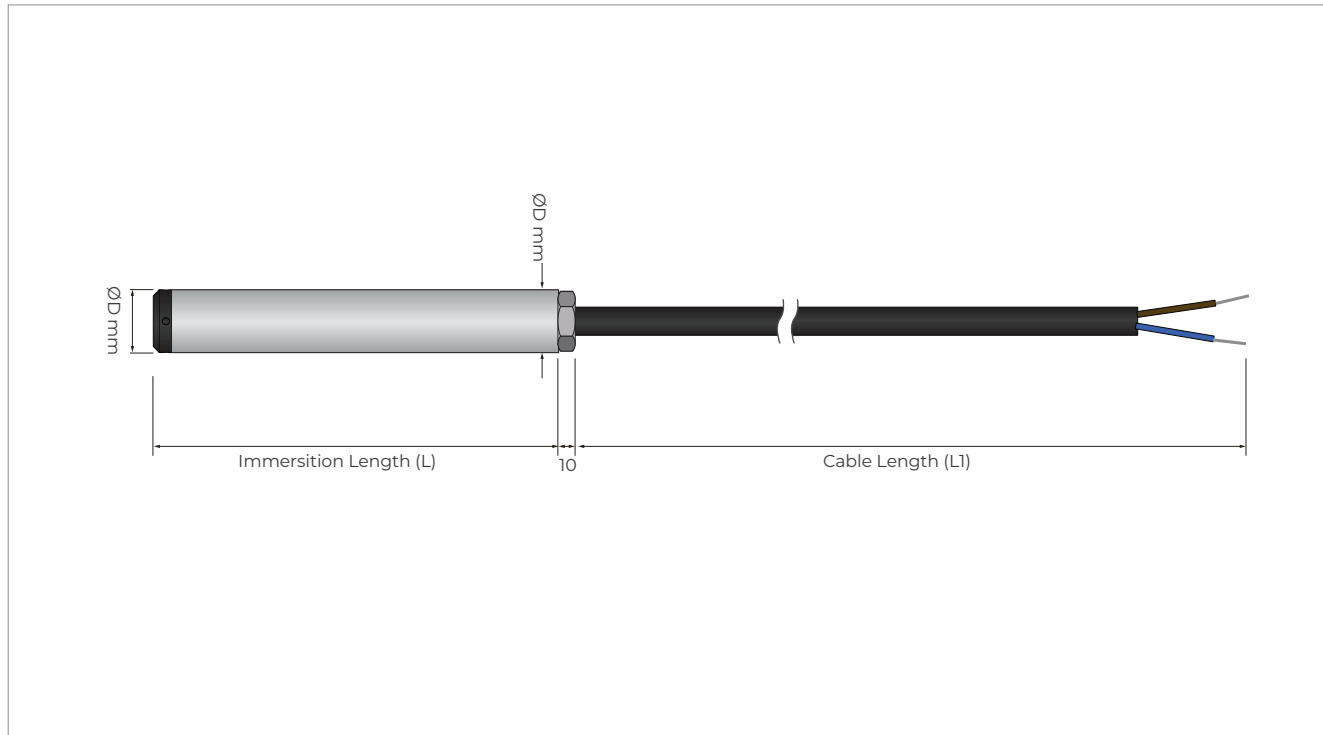

### Product Features

<b>Measurement Range</b>	0...500 mWC (0...50bar)
<b>Sensor Material</b>	1.4404 Stainless Steel 316L
<b>Cable Material</b>	PE
<b>Process Temperature</b>	0...+70°C
<b>Sensor Diameter</b>	Ø 26 mm
<b>Supply Voltage</b>	10...36 V DC (volts direct current)
<b>Output Signal</b>	4-20 mA (2 or 3 wire) / 0-10 V / Modbus RTUOptions)
<b>Protection Class</b>	IP68

# Hydrostatic Level Transmitter

## MODEL RM L01S

### Working Principle

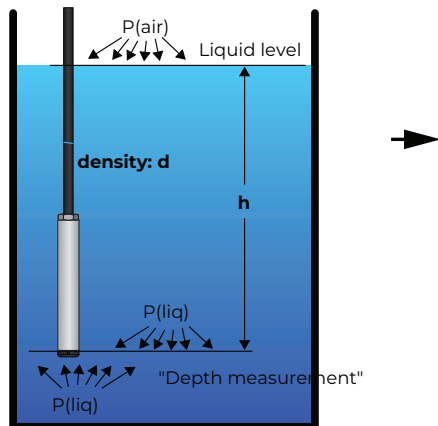

$$P(\text{liq}) = d \times g \times h + P(\text{air})$$

Liquid Pressure = (Density x Gravity x Height) + Atmospheric Pressure

In this context, P(liq) represents the atmospheric pressure acting on the surface of the liquid, and g denotes the gravitational acceleration (a constant value). When these constant values are substituted into the equation, the relationship between liquid level and pressure simplifies as follows:

$$P(\text{liq}) - P(\text{air}) = K \times h$$

In short: The pressure difference represents the liquid level. In summary; the measured pressure difference directly represents the liquid level. The most commonly used unit in the industry for this measurement is mH<sub>2</sub>O (meters of water column)

The Reinmeer Etrans-L01 hydrostatic level transmitter senses the total pressure applied by the liquid (P(liq)) and subtracts the atmospheric pressure (P(air)) from this value using a special air-vent tube located inside the connection cable. This process is performed via a single pressure-sensitive diaphragm.

#### Sensing Technology

As the transmitter is submerged deeper into the liquid, the liquid pressure (P(liq)) becomes higher than the atmospheric pressure (P(air)), causing a microscopic deformation in the sensor diaphragm.

This invisible diaphragm deformation is detected by Piezoresistive sensors placed on the high-precision diaphragm. Piezoresistive sensors convert the physical change in the diaphragm into electrical resistance.

#### Conclusion

As a result, the pressure applied by the liquid is precisely sensed by the Reinmeer Etrans-L01 and converted into an electrical signal that directly indicates the depth (level) from the liquid surface.

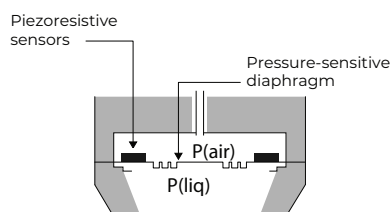
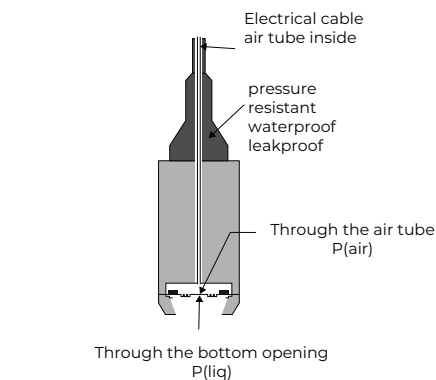

Air is drawn back through the air tube.

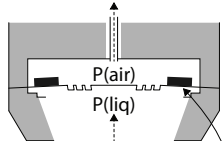

The liquid exerts more pressure on the diaphragm at greater depth; the piezoresistive sensor then converts the diaphragm's deformation into electrical resistance.

### Application

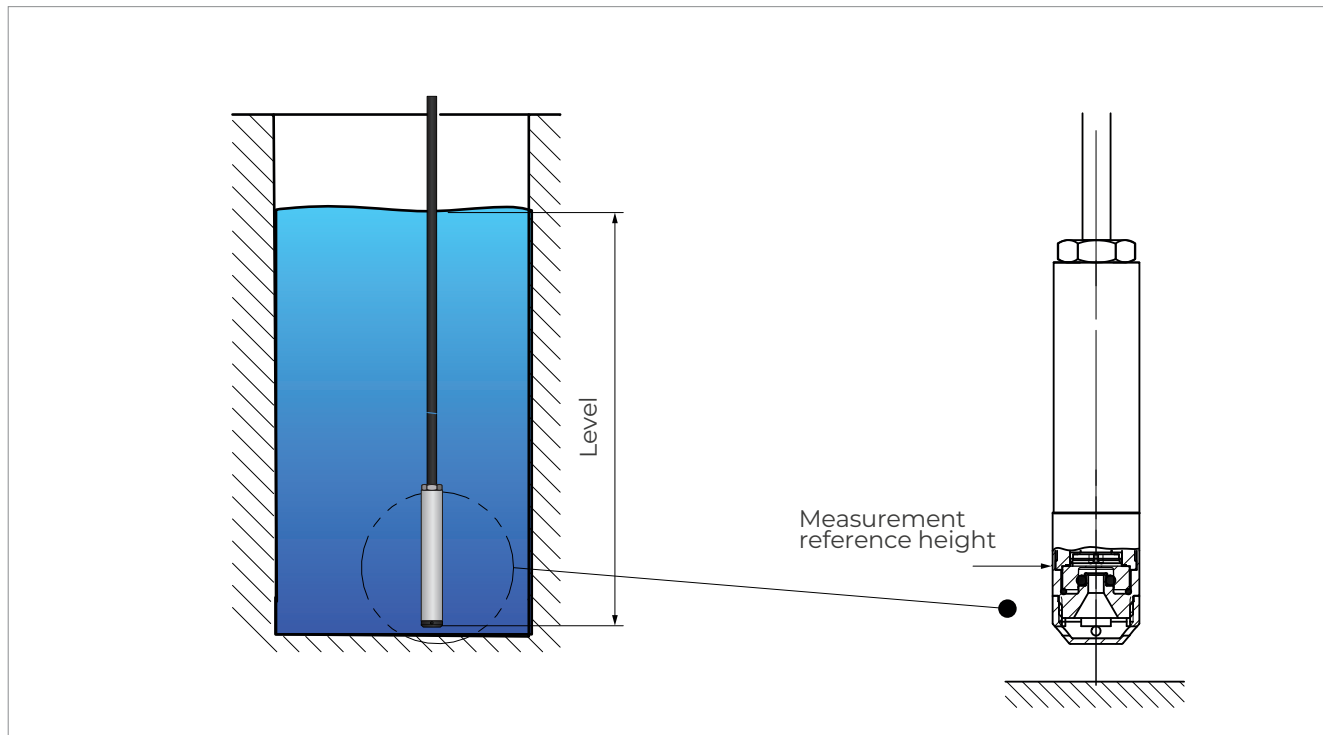

### Advantages:

- **Easy Installation and Setup:**

Requires no drilling or mounting at the bottom of the tank or well. It is easily installed by suspending it from its cable, which makes it highly practical for use in existing facilities (retrofit).

- **Unaffected by Environmental Conditions:**

Unlike ultrasonic sensors, conditions such as foam, vapor, or turbulence on the liquid surface do not affect hydrostatic measurement. Since it measures pressure from the bottom, it always provides stable results.

- **Ideal for Deep Applications:**

It is the most economical and reliable solution, especially for deep water wells and very tall tanks (100 meters and above). It is preferred when other technologies (such as radar) have insufficient range or are too expensive.

- **No Moving Parts:**

Unlike mechanical float systems, it has no moving parts. This eliminates the risk of mechanical jamming, sticking, or wear, resulting in very low maintenance requirements.

- **Economic Solution:**

Despite offering high precision, its initial investment cost is much lower compared to radar or ultrasonic level sensors. It is one of the sensor types with the highest price/performance ratio.

- **Independent of Tank Shape:**

Narrow tanks or the presence of agitators and obstacles inside the tank do not affect the measurement. The sensor works accurately as long as it is at the bottom of the liquid.

### Assembly Methods

#### A. Installation in Static Water

The installation method in stagnant water is shown in Figure 1.

To prevent turbulence during pumping or filling from shaking the transmitter or damaging the device, the transmitter should be placed as far away as possible from the liquid inlet/outlet source (pump nozzle).

If installation in a turbulent area is unavoidable, the transmitter must be mounted by fixing it inside a steel pipe (protective sheath), as shown in Figure 2.

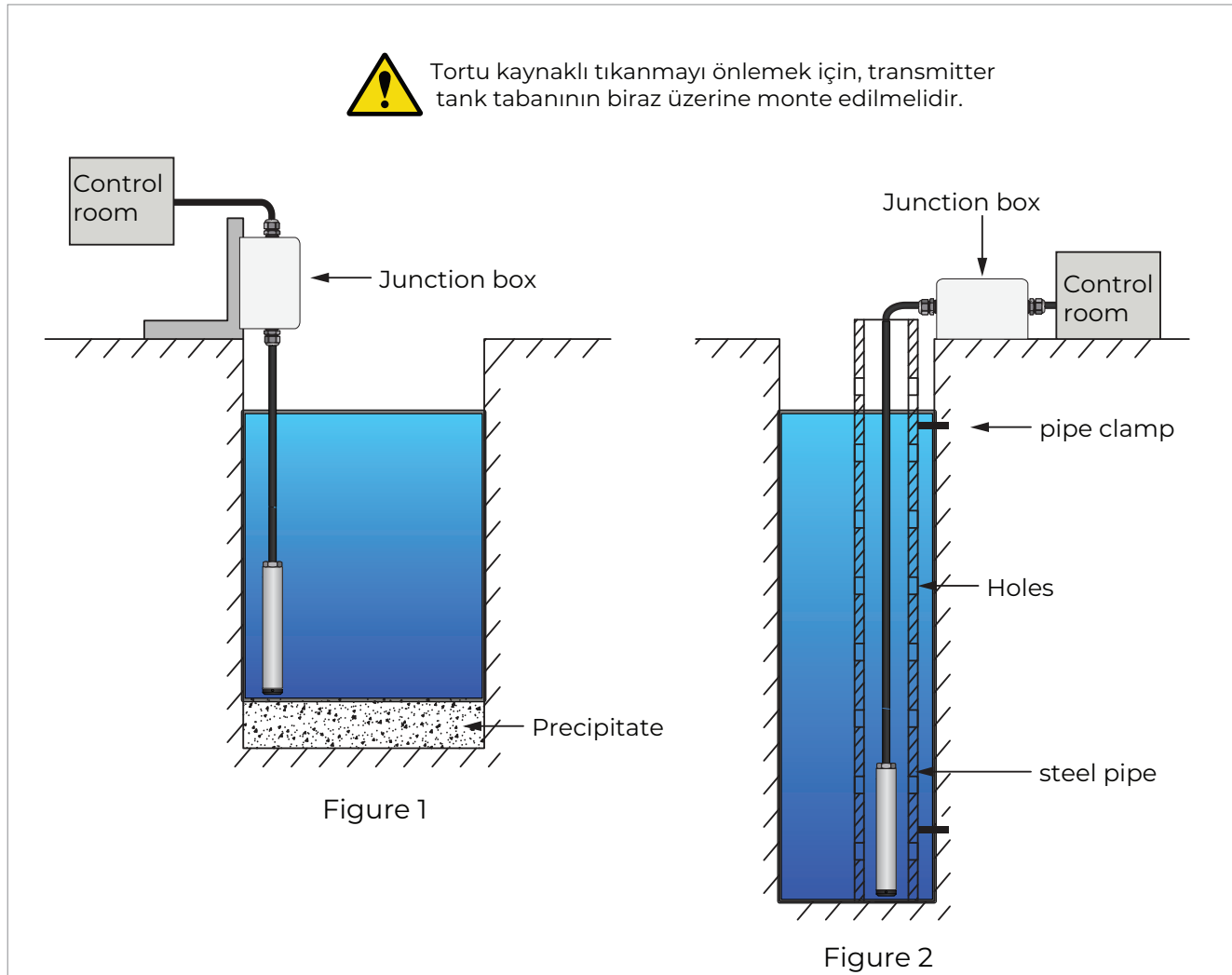

### B. Installation in Flowing Waters (e.g., River channel, reservoir area)

In this type of application, it is necessary to use equipment that will calm (slow down) the water flow.

Method 1: Placing a steel pipe in the water channel (Figure 3). The steel pipe used must have a high (thick) wall thickness. To dampen waves and eliminate the effect of pressure changes caused by flow, holes should be drilled in the pipe at different heights.

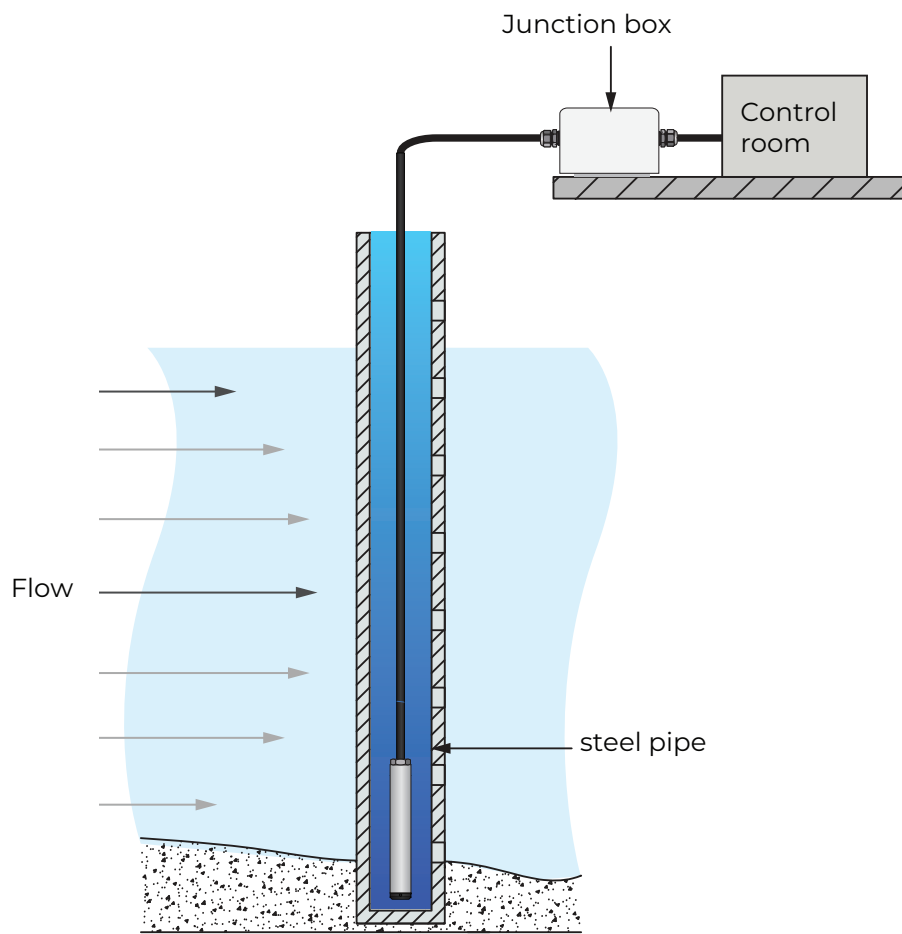

Figure 3

# Hydrostatic Level Transmitter MODEL RM L01S

REINMEER

Data sheet Model RM L01S

"Method 2: For channels with sandy and stony ground structures, the superficial embedding method is more suitable (Figure 4). This method not only eliminates the flow pressure of water and the effects of waves but also filters sand and mud."

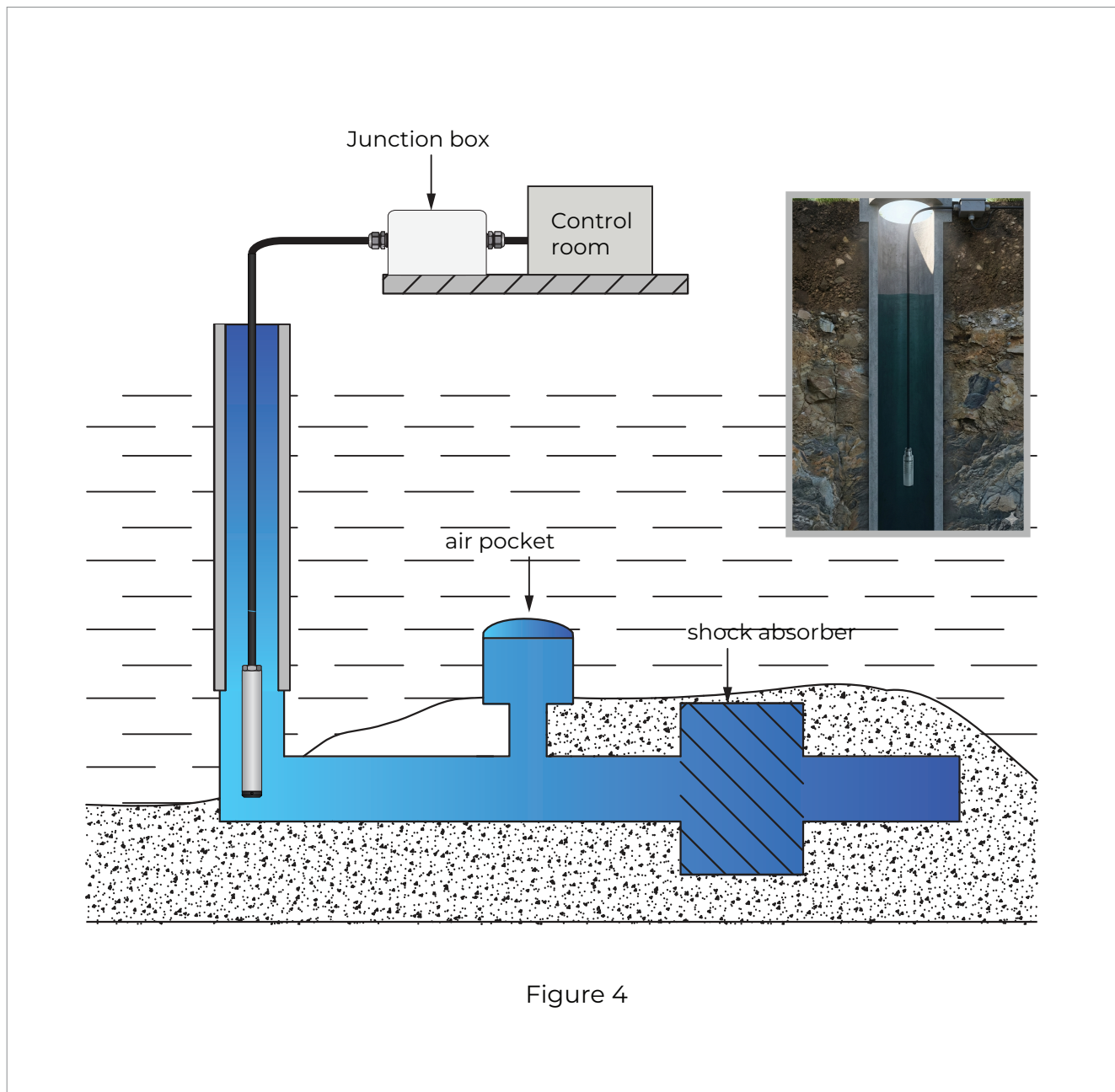

### Electrical Connections

