

## RM-OC901

### OC901 Type: Single Thermocouple Input Oven Control Devices

#### Description

OC901 Model devices are 96x96 mm sized oven control devices that perform temperature control with a single thermocouple and are used for time-dependent baking processes. They are fully modular devices capable of temperature control with On/Off control, featuring Automatic/Manual steam generation, providing an alarm at the end of the time, and each module can be configured independently. Thanks to its universal power supply, it can be used with a 100-240VAC/DC or 24V power supply.



#### General Features

- Display: LCD Display
  - 3 Pieces 4-Digit Numeric Displays
  - LED Indicators for Relays
  - 1 Sensor Input (B, E, J, K, L, N, R, S, T, U)
  - 2 Analog Outputs (0/4-20mA, 0/2-10V)
  - 1 RS485 Communication Unit
  - 4 Relay or Logic Outputs (24V)
  - 100-240V AC/DC Universal or 24V AC/DC Supply
  - Isolation Between Input/Output Modules
  - Temperature Control Output (ON/OFF or PID Control)
  - Independent Temperature and Time Setting Feature
  - 0...9999 or 0.0...999.9 Temperature Set Value Adjustment
  - 0...999 Time Setting (Seconds, Minutes, Hours)
  - Continuous or Time-Dependent Alarm at the End of Time
  - Automatic / Manual Steam Feature
  - Steam Duration Adjustment between 1...9999 Seconds
  - Temperature Offset Feature
  - Sensor Failure Detection
  - Retransmission (For process and set value)
  - 15Vdc Logic Inputs
  - Customization: Custom Software Can Be Developed for
  - Logic Inputs Upon Request. (For example: Start/Stop or Steam Generation connected to a Door Switch).
- NOTE: Programmatic requests related to the customer-specific operation of the device can be made.

#### Device Dimensions

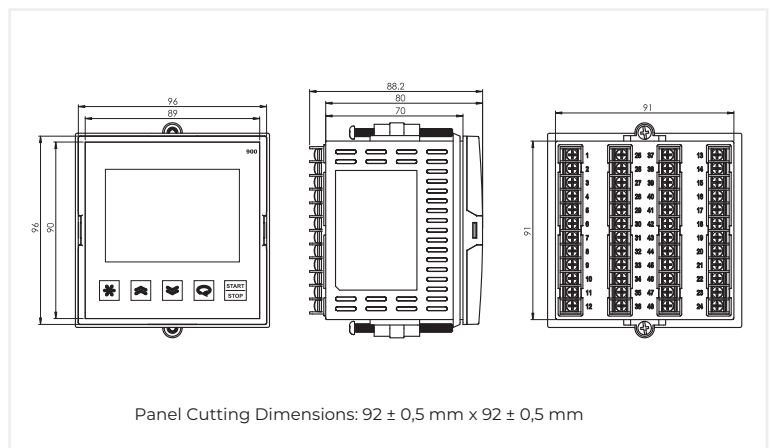

#### Applications

Food, Plastic, Iron & Steel, Chemical, Metallurgy, Cement, Ceramics, Petro-Chemistry, Refineries, Glass, and other industrial sectors.

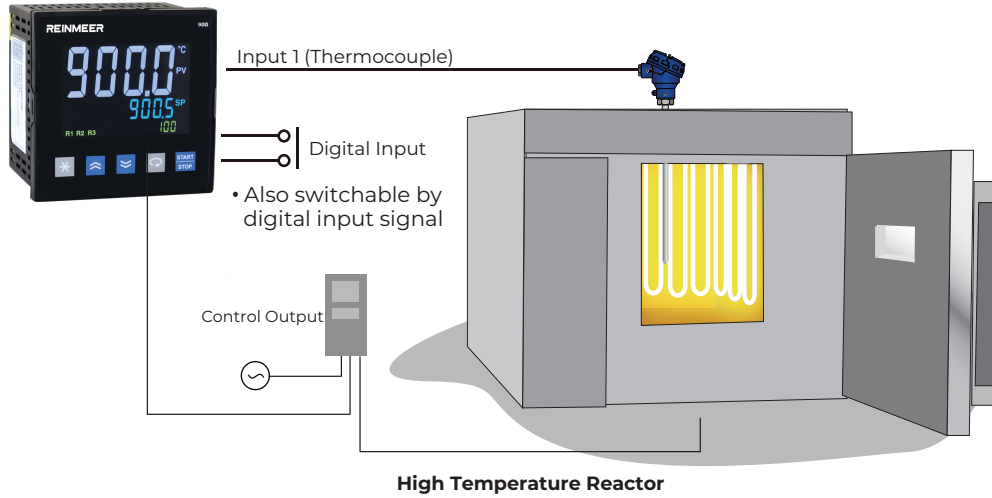

## Technical Specifications

Supply Voltage (PS)	100-240 Vac/dc +10% -15% 24 Vac/dc +10% -20%
Power Consumption	4W, 6VA
Universal Sensor Input (S1)	Thermocouple: B, E, J, K, L, N, R, S, T, U Analog Input Imped.: Thermocouple, mV = 10 M $\Omega$ Current: 0/4-20mA, 20-4/0mA (RL $\geq$ 500 $\Omega$ ) Voltage: 0/2-10V (RL $\geq$ 1 M $\Omega$ )
Relay Outputs (R1, R2, R3, R4)	Contact (R1, R2, R3, R4): 250VAC 10A Logic Output = 24Vdc 20mA
Contact Life	No Load = 10,000,000 Switching 250V 10A Resistive Load: 1,000,000 Switching
Other	Memory: 100 Years, 100,000 Renewals Accuracy: $\pm$ 0.2% Sampling time: 100 ms Operating temperature: -10...+55°C Storage temperature: -20...+65°C
Protection class:	Front panel IP54 / Rear panel IP20
Mechanical Specifications	Width: 96 mm Height: 96 mm Depth: 78.2 mm Panel cut-out: 92 $\pm$ 0.5 mm x 92 $\pm$ 0.5 mm Weight: 430 g

## Electrical Wiring Diagram

