

RM-PC1100

Advanced Step Controllers

Description

PC1100 Model devices are 96x96 mm sized devices designed for the measurement of many process variables in industrial environments such as temperature, pressure, speed, level, humidity, current, voltage, resistance, and other physical units, as well as for open/closed loop and PID control. They are completely modular, and each module can be configured independently. They are used in Food, Plastics, Iron & Steel, Chemistry, Metallurgy, Cement, Ceramics, Petro-Chemistry, Refineries, Glass, and other industrial branches. They are ergonomic devices based on compliance with international standards, reliability, and ease of use during the design phase.



General Features

- 2 Independent 3-Line 4-Digit Numeric LCD Displays.
- 4 Separate Capacitive Buttons for Each of the Two Sensor Inputs.
- LED Indicator for Relay Outputs.
- 2 Transmitter Supply Outputs (24VDC).
- 2 Universal Sensor Inputs (TC, RT, mA, mV, V).
- 2 Auxiliary Analog Inputs (0/4-20mA).
- 2 Potentiometer Inputs.
- 4 Digital Inputs (15V).
- 2 Analog Outputs (0/4-20mA, 0/2-10V).
- 2 RS485 Communication Units.
- 4 Relay or Logic Outputs (24V).
- 100-240V AC/DC Universal or 24V AC/DC Supply.
- Isolation Between Input and Output Modules.
- 800 Steps, 100 Program Step Control.
- Ability to Program Relay Positions in Steps.
- 7 Different Power Failure Behaviors.
- Configuration via Computer.
- Control Based on Auxiliary Analog Input Information Difference.
- Proportional Valve Control with Position Feedback.
- Proportional Valve Control without Feedback (Floating Control) PID Heating/Cooling.
- Auto-Tuning (Automatic adjustment of PID parameters).
- Programmed / Automatic / Manual Operation Modes.
- Sensor Fault Detection.
- Remote Set Point.
- 4 Selectable Set Points.
- Ramp Function.
- Retransmission (For Process and Set Value).
- 18 Different Relay Functions.
- ON/OFF, P, PI, PD, PID Control.
- Linear and Time-Proportional Control Output.
- 100ms Sampling and Control Cycle.
- Standard MODBUS RTU Communication Protocol.
- Master-Slave and Cascade Control Applications.

Device Dimensions

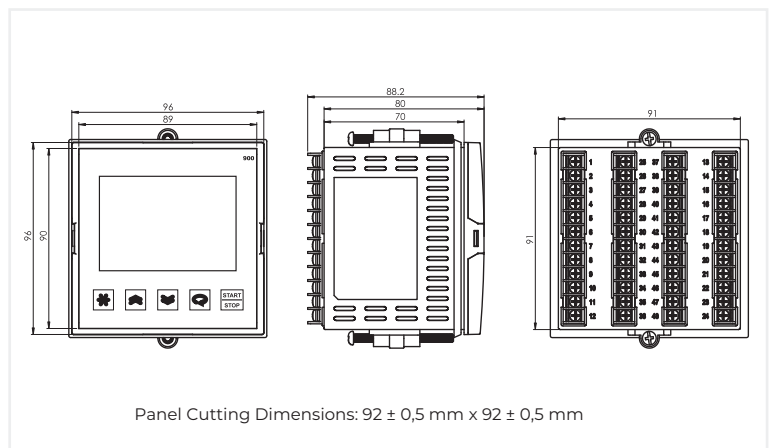

Applications

They are used in Food, Plastics, Iron & Steel, Chemistry, Metallurgy, Cement, Ceramics, Petro-Chemistry, Refineries, Glass, and other industrial branches.

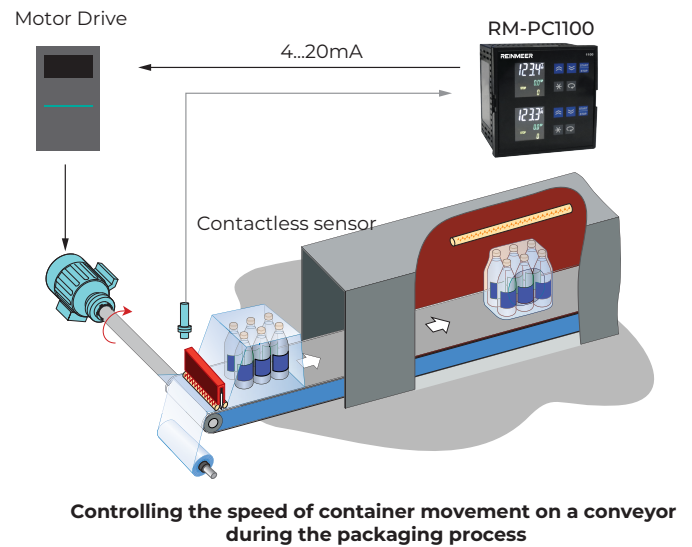
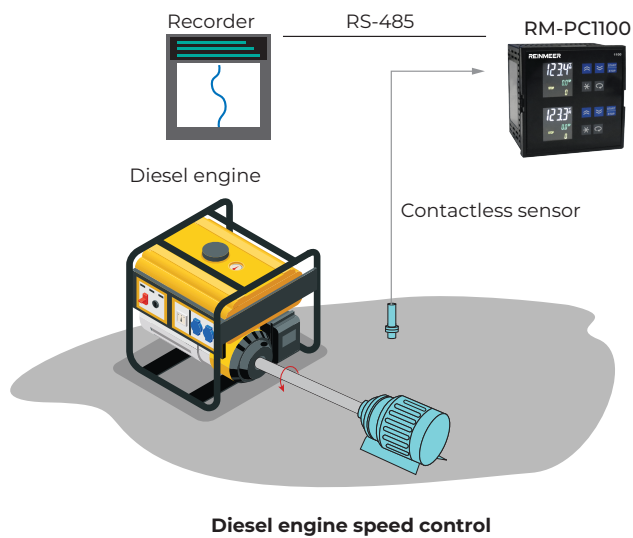

Technical Specifications

Supply Voltage (PS)	100-240V AC/DC (+10% / -15%) or 24V AC/DC (+10% / -20%).
Power Consumption	6W / 10VA.
Universal Sensor Input (S1)	Thermocouple = B, E, J, K, L, N, R, S, T, U Two-Wire Transmitter = 4-20mA Resistance Thermometer = Pt-100 Current = 0/4-20mA Voltage = 0-50mV, 0/2-10V
Auxiliary Analog Input (S2)	0/4-20mA
Potentiometer Input (S3)	100-15000Ω
Transmitter Supply (TX)	24Vdc (Isc=30mA)
Analog Input Impedances	Thermocouple, mV: 10MΩ Current: 10Ω Voltage: 1MΩ
Analog Outputs (O1, O2)	Current: 0/4-20mA (RL ≥ 500Ω) Voltage: 0/2-10V (RL ≥ 1MΩ)
Relay Outputs (R1, R2, R3, R4)	Contact (R1, R2, R3, R4) : 250VAC 10A Logic Output = 24Vdc 20mA
Contact Life	No Load = 10,000,000 Switching; 250V 10A Resistive Load = 1,000,000 Switching.
Other	Memory: 100 Years, 100,000 Renewals. Accuracy: ± 0.2% Sampling time: 100 ms Operating temperature: -10...+55°C Storage temperature: -20...+65°C
Protection class:	Front panel IP54 / Rear panel IP20
Mechanical Specifications	Width: 96 mm Height: 96 mm Depth: 78.5 mm Weight: 430 gr
Panel Cut-out Dimensions	92 ± 0,5 mm x 92 ± 0,5 mm

Electrical Wiring Diagram

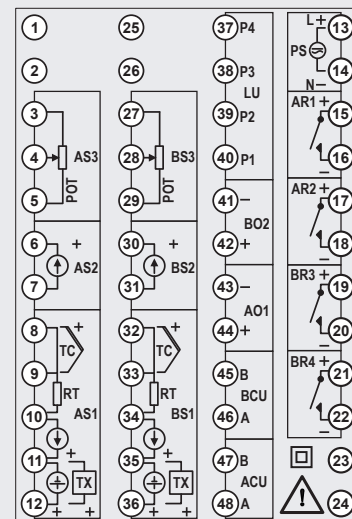

Module	Description
AS1, BS1	Indicates the first and second universal sensor inputs. Input types are changed via the device.
AS2, BS2	0/4-20mA auxiliary analog input module (The function of this module can be selected via the device).
AS3, BS3	100-1500Ω Potentiometer input module (The function of this module can be selected via the device).
LU	Logic input module.
ACU, BCU	RS485 MODBUS RTU module.
AO1, BO2	Analog output modules. (The content of this module is determined by the product code, while functions can be selected via the device).
AR1, AR2, BR3, BR4	Relay output modules. (The content of this module is determined by the product code, while the function is selected via the device).
PS	Supply voltage input. (Supply voltage is determined by the product code).