

RM-V-D SERIES SUBMERSIBLE TYPE VORTEKS FLOW METER



LIQUID

GAS

STEAM

RELIABLE MEASUREMENTS FOR
THE RIGHT DECISIONS

REINMEER

RM-V-D SERIES SUBMERSIBLE TYPE VORTEKS FLOW METER

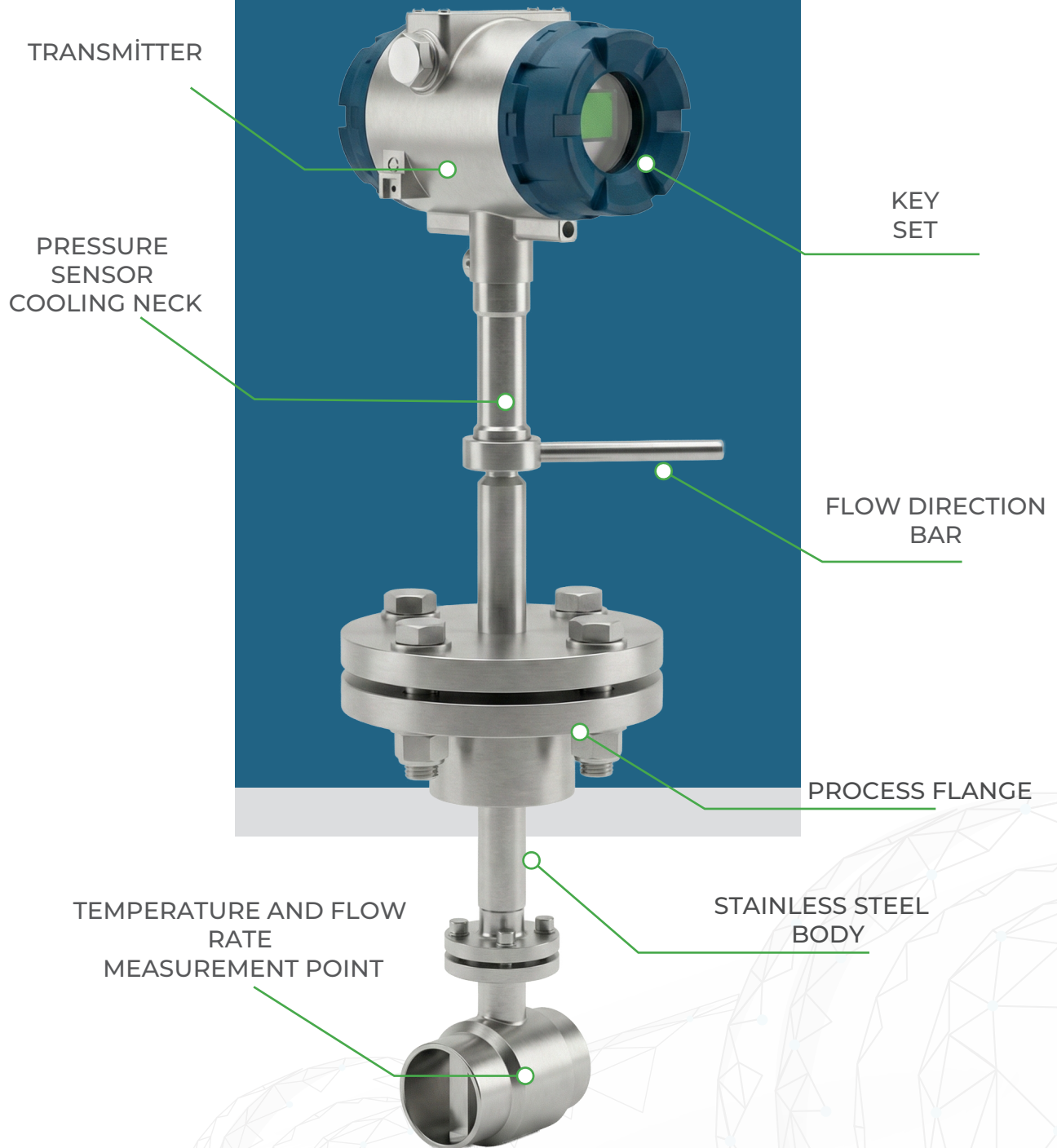

www.reinmeer.com

WORKING PRINCIPLE

The measurement principle of vortex flowmeters is based on the physical phenomenon known as the Kármán Vortex Street.

This principle is based on the fact that when a fluid (liquid or gas) passes around an obstacle (blow body), it creates regular vortices.

The operating principle of this type of vortex flowmeter is based on the analysis of the vortex shedding phenomenon created when a fluid passes over an obstacle. This is also known as the turbulence principle and occurs regardless of the shape of the object through which the flow passes.

The simplest way to understand this effect is with the example of a flagpole and a flag. Here, air is the fluid, and the pole acts as a solid obstacle. As air flows around the pole, vortices are formed, which can be observed as the flag fluttering.

The obstacle (bluff body) used in industry is usually cylindrical or prismatic in shape and is mounted perpendicular to the flow direction. The measurement is based on determining the frequency of the vortices that are formed.

Working Mechanism:

- As the fluid passes around the body, it creates vortices.
- Each vortex passage creates a small change in pressure.
- These pressure changes are detected by a piezoelectric sensor or a capacitive sensor.
- The measured frequency signal is processed by the flowmeter's electronic unit.
- The volumetric flow rate (Q) is calculated based on the relationship between frequency and velocity:

$$Q = A \cdot V$$

Q = Volumetric flow rate (m³/s)

A = Pipe cross-sectional area (m²)

V = Flow velocity (m/s)

For vortex flow meters to provide accurate and reliable measurements, installation, process conditions, and environmental factors must be carefully evaluated.

Basic Relationship (Formula):

$$f = St \cdot \frac{V}{d}$$

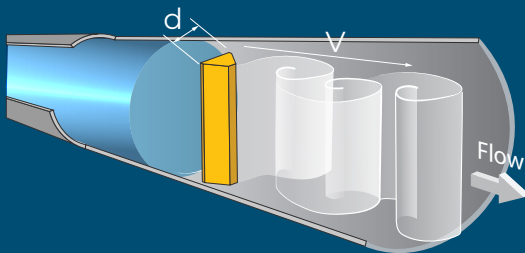

f = Vortex formation frequency (Hz)

St = Strouhal number (dimensionless constant, typically between 0.17–0.25)

V = Flow velocity (m/s)

d = Obstacle width (blow) (m)

Advantages:

- No moving parts → low maintenance requirements
- Wide measurement range (stable in flows with Reynolds numbers above 10,000)
- Suitable for liquid, gas, and steam measurements
- Pressure and temperature compensation ensures high accuracy

STRUCTURE OF VORTEX FLOWMETERS

Der Vortex-Durchflussmesser besteht aus einem Hindernis (Blöfkkörper), das Kármán-Wirbel erzeugt, einem Sensor, der diese Wirbel erfasst, und einem Transmitter (Sender), der die vom Sensor empfangenen Signale verarbeitet.

Wenn die Flüssigkeit auf beiden Seiten des Blöfkkörpers nacheinander Kármán-Wirbel erzeugt, entsteht auf dem Sensor eine wechselnde Spannung (mechanische Beanspruchung). Diese Spannung wird von einem piezokeramischen Element erfasst; das Signal wird anschließend vom Sender verstärkt und geformt.

Das Ergebnis ist ein Impulsausgang, der proportional zur Strömungsgeschwindigkeit ist.

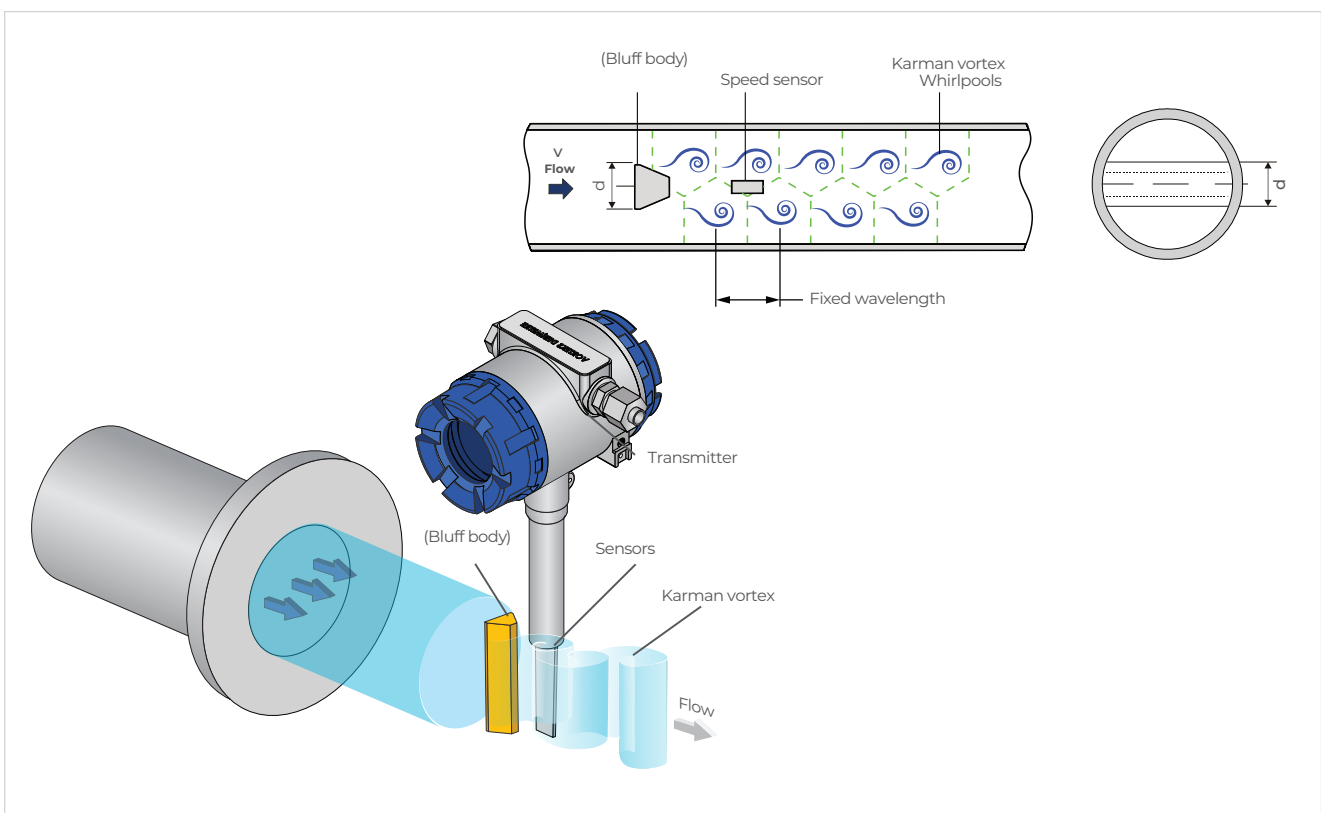
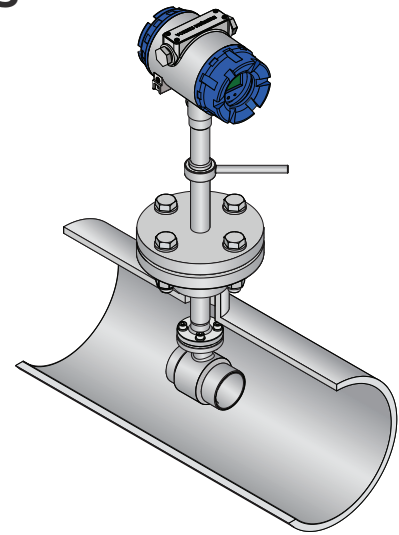

Flowing part:

This is the part of the flowmeter through which the fluid passes and is usually mounted directly onto the pipe.

Bluff body:

This is a solid part placed perpendicular to the flow direction. As the flow passes around this part, it creates vortices. It can be cylindrical, square, triangular, or polyhedral in shape.

Sensors:

Detect turbulence and pressure changes.

Transmitter:

Analyzes signals received from sensors and converts them into electrical output.

Additionally, auxiliary devices such as a calculator or a normalizing converter can be integrated into the system.

APPLICATION AREAS

Vortex flow meters are widely used in industrial processes where precise measurement of liquid, gas, and vapor flows is required. They are particularly preferred in fields such as chemical, petrochemical, energy production, food, pharmaceutical, and HVAC systems. Thanks to their resistance to pressure and temperature changes, they provide reliable results in both saturated and superheated vapor measurements. Furthermore, their lack of moving parts minimizes maintenance requirements and offers long-term usability.

In addition, vortex flow meters are effectively used in water treatment plants, compressed air systems, and fuel and natural gas pipelines. With their wide measurement range and high accuracy, they play a significant role in process control and energy management. They can be easily integrated into automation systems with digital output signals, which provides a major advantage in terms of data monitoring and energy optimization.

Chemical Industry



Power Plants



Food Industry



Water and Wastewater



Petrochemicals

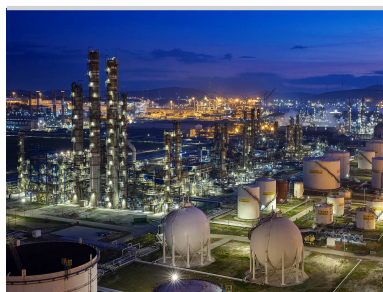

Pharmaceutical Industry



Installation Recommendations

For accurate measurements when installing insertion-type vortex flow meters, flow line conditions, installation direction, and sensor position are critical. The sensor is typically mounted perpendicular to the pipe axis. The flow direction must match the flow direction arrow on the device.

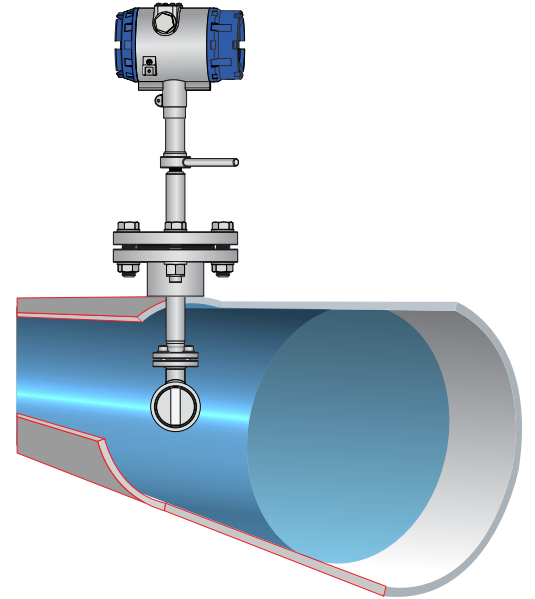
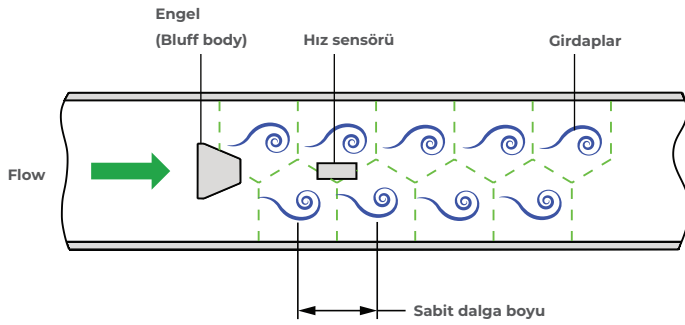

Pre-Installation Warnings

1. Since the immersion-type vortex flowmeter is directly immersed in the flow on the pipeline, misalignment or improper orientation during installation may cause damage to the device.
2. The flow direction must be checked before installation and must be consistent with the direction indicator on the device.
3. If there is a risk of vibration or impact on the line where the device is installed, it must be secured with appropriate clamps or supports.
4. Process pressure and temperature must not exceed the device's technical limits.
5. The immersion depth is generally recommended to be approximately 1/3 of the pipe diameter into the flow (it should be located close to the centerline of the pipe).

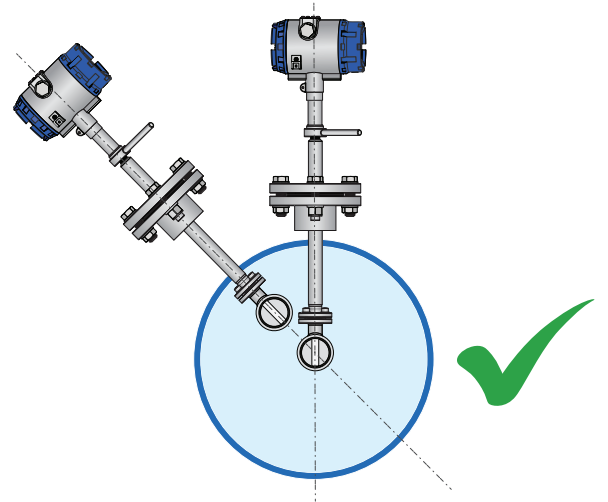

Warning – Safety and Health Precautions



This device should only be installed, commissioned, and maintained by authorized and trained personnel.

The device's power must be completely disconnected during installation and maintenance.

Before working on pressurized lines, the fluid and pressure in the system must be completely drained.

When making electrical connections, the risk of sparks in explosive environments must be taken into account.

All connections must be made in accordance with local occupational safety regulations (e.g., Regulation on Health and Safety Conditions in the Use of Work Equipment).



TECHNICAL SPECIFICATIONS

Standard Body

Measurement Range	Liquid: 0.25 ft/s to 9.5 ft/s Gas: 4 ft/s to 78 ft/s Vapor: 3 ft/s to 78 ft/s
Measurable Fluids	Liquid, gas, vapor
Average Pressure	1.0MPa, 1.6MPa, 2.5MPa Standard (Optional 4.0 MPa DN15...up to DN 80)
Special range	Customer Pressure information according to DN15-DN300
True Error Rate Full Type	liquid: ± 0.5%, gas and vapor ± 1.0%, ± 1.5%
Ratio Scale	1:10, 1:20, 1:30, 1:40
Friction Coefficient Full Type	Cd < 2.4
Vibration	Max. 2g
Process Temperature	Normal Environment -40°C ~ +250°C; Optional -40°C ~ +350°C;
Material	316 SS / 304 SS

Transmitter

Body Material	Cast Aluminum	
Installation Method	Cylindrical Compact	
Supply Voltage	12...32VDC	
Local Screen	Backlit LCD Display 64x128	
Display Languages	English	
Output Signals	Standard (4-20 mA, Frequency, Pulse)	
Process Temperature	-20 ... +70 °C (Depending on process temperature)	-40 to +85 °C (Separate model)
Communication	RS485 MODBUS (Standard)	HART optional
Protection Class	IP67	

Transmitter

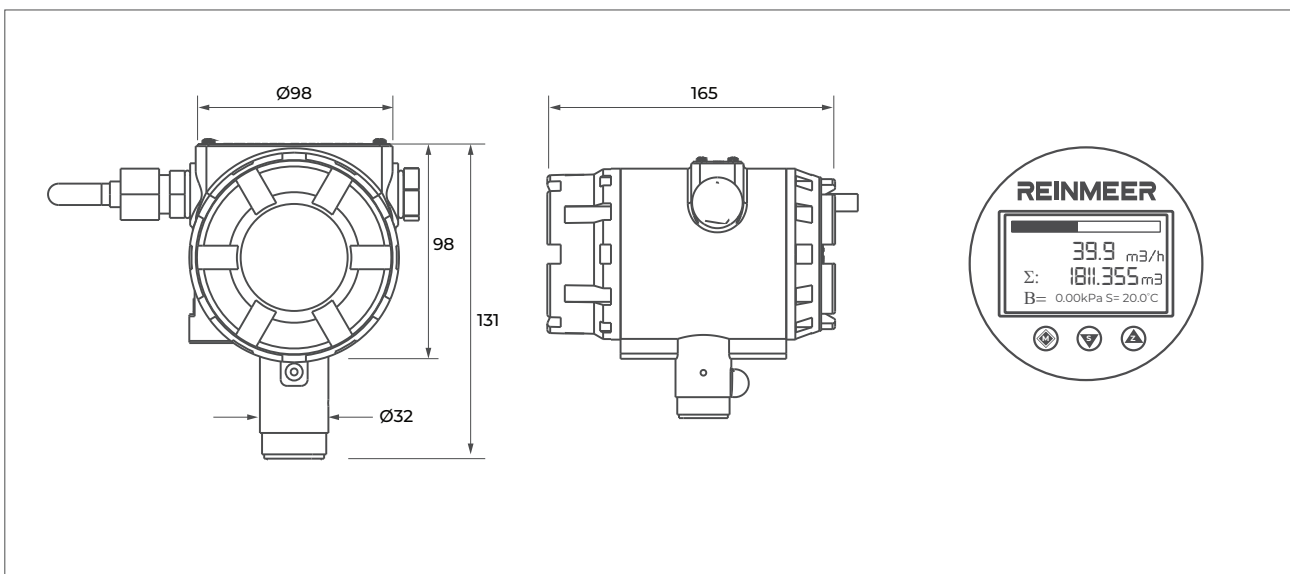

TECHNICAL DRAWING

FRONT VIEW OF THE SENSOR

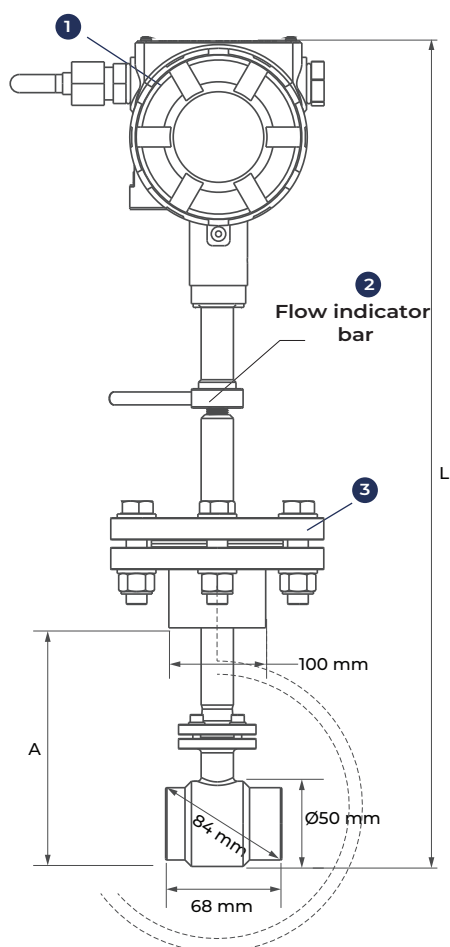

SENSOR'S SIDE VIEW

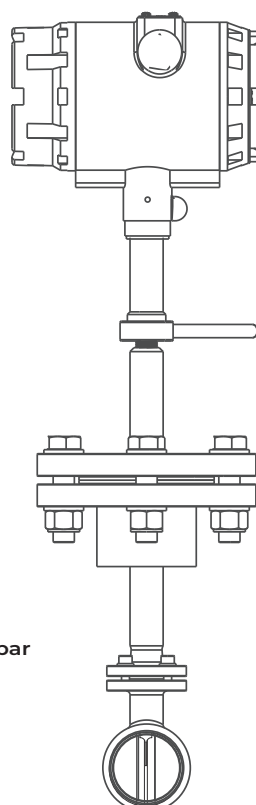

- 1 Transmitter
- 2 Flow indicator bar
- 3 Flange

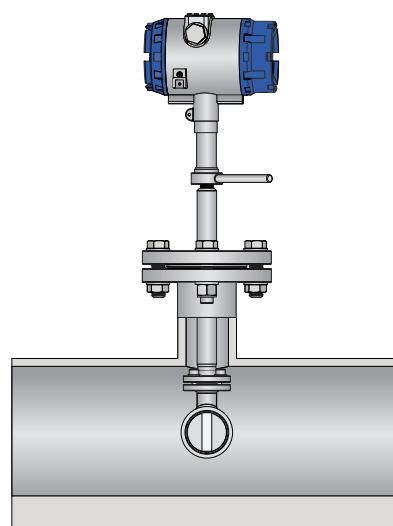

DN (mm)	A	L
DN150	103	498
DN200	128	523
DN250	153	548
DN300	178	573
DN400	228	623
DN500	278	673
DN600	328	723
DN700	399	794
DN800	428	823
DN1000	528	923
DN1500	778	1173

Project / Drawing

Revision

Not

1. All dimensions are shown

Designer

Scale

1.12

No.

SENSOR MOUNTING METHOD

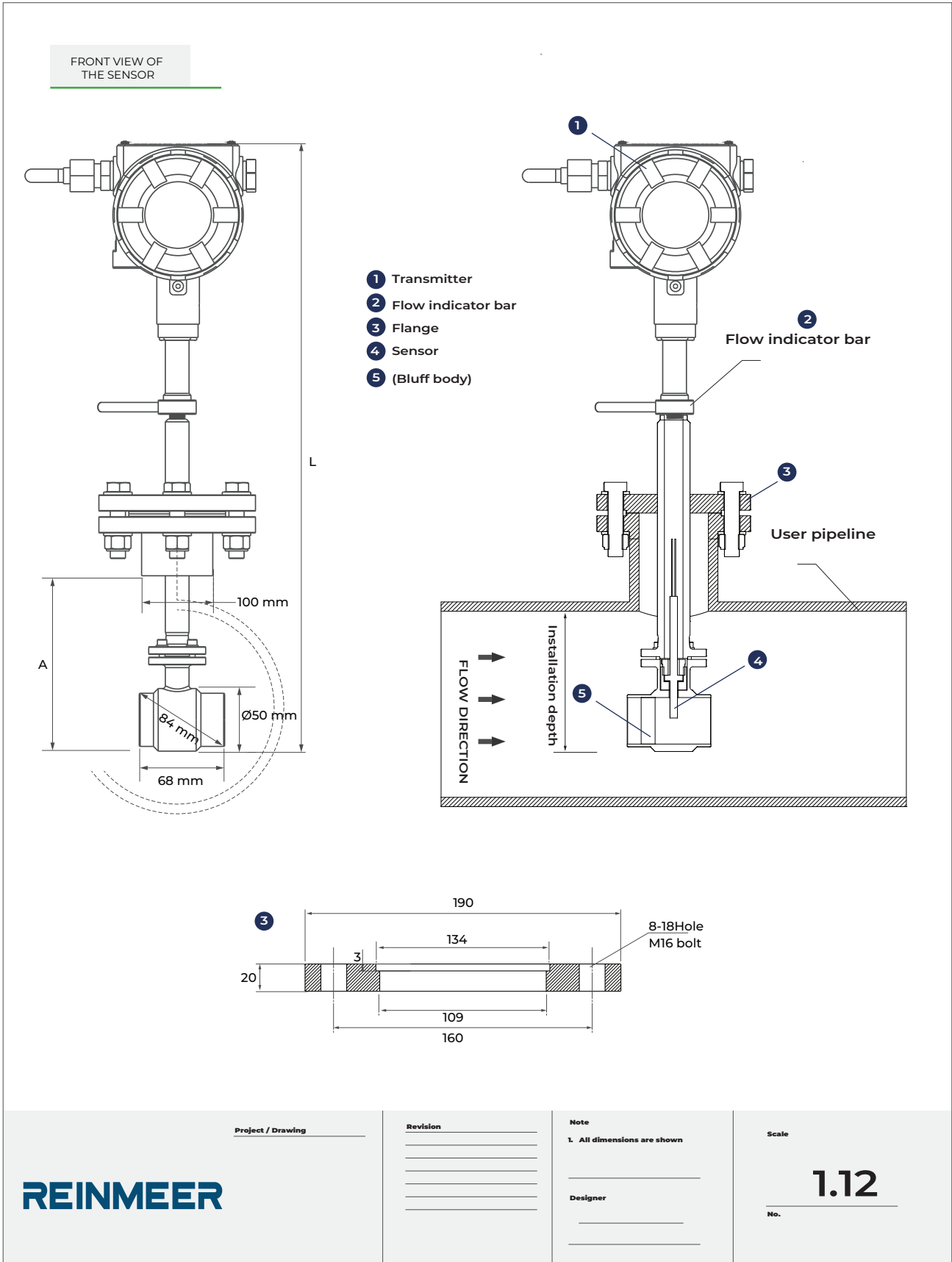

TECHNICAL DRAWING

SENSOR INTERIOR
DETAIL VIEW

Transmitter

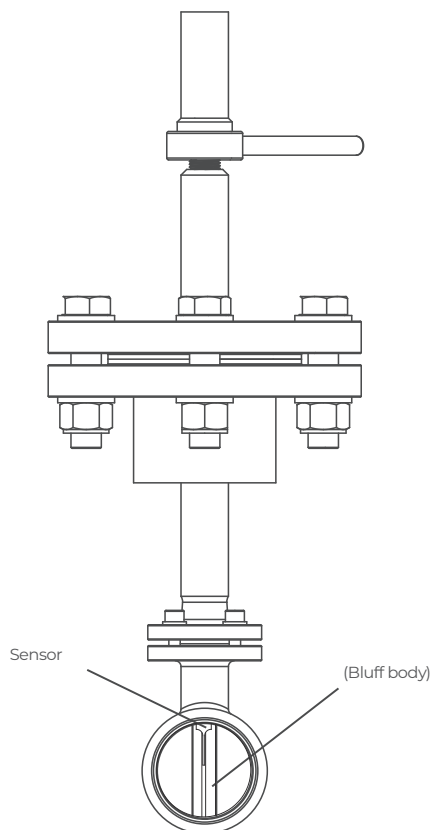
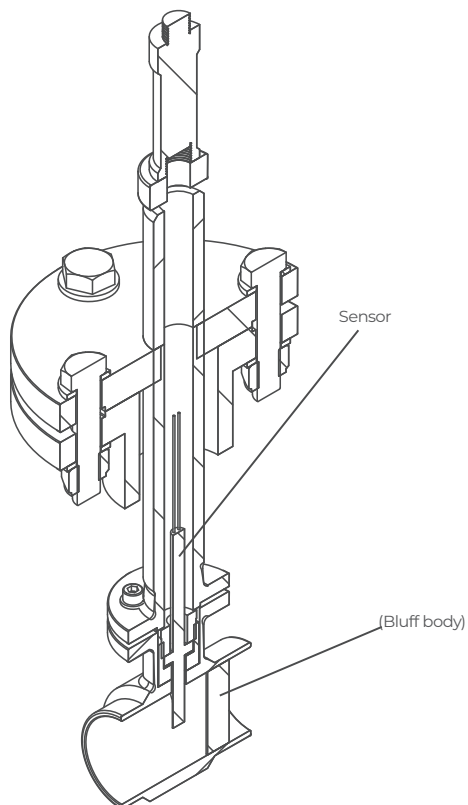
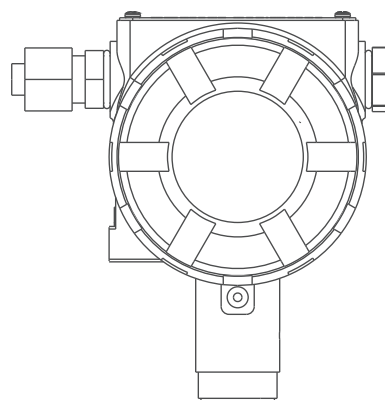
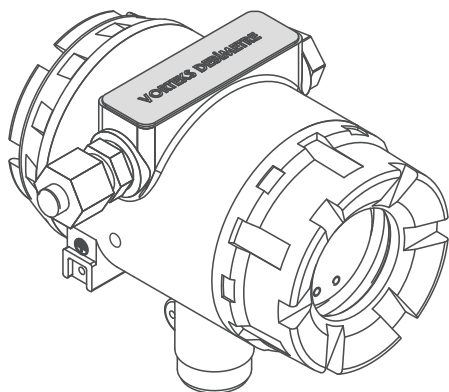

REINMEER

Project / Drawing

Revision

Not

1. All dimensions are shown

Designer

Scale

1.12

No.

MEASURABLE FLOW RATES ACCORDING TO PRODUCT DIAMETERS AND FLUID TYPE

DN (mm)	K-Factor	Liquid (m3/h)	Frequency (HZ)	Gas (m3/h)	Frequency (HZ)	Steam (m3/h)	Frequency (HZ)
DN 15	350000	0.3-9	88-580	3-50	240-2350	4-50	260-2000
DN 20	148000	0.5-15	38-422	5-80	210-2132	7-80	210-1900
DN 25	74980.3	0.6-18	25-336	6-120	190-1140	10-80	210-1680
DN 32	30511	1-30	16-264	10-150	150-1100	12-120	156-1080
DN 40	17523.5	1.6-48	10-200	16-320	10-1040	25-180	126-910
DN 50	9451.2	5.5-75	8-160	25-500	94-1020	40-260	100-700
DN 65	4113	4-120	6.1-77.1	40-800	80.7-807	35-800	94-940
DN 80	2346	6-180	4.1-82	60-1250	55-690	100-800	63-500
DN 100	1153.5	10-300	4.7-69	100-2000	42-536	160-1100	50-350
DN 125	573.1	15-450	3.3-41.6	150-3000	38-416	150-2000	38-475
DN 150	334	22-660	2.8-43	200-4500	33-380	400-3500	38-350
DN 200	141.5	40-1200	2-31	300-8000	22-315	580-7000	23-270
DN 250	70.8	60-1800	1.5-25	500-12000	18-221	960-9600	20-200

SATURATED VAPOR PRESSURE-BASED FLOW RATE CHANGE TABLE

DN (mm)	Flow	Measurable Flow Rates (kg/h)								
		1 Bar	2 Bar	4 Bar	6 Bar	8 Bar	10 Bar	15 Bar	20 Bar	25 Bar
DN 15	Min	2,2	3,2	5,1	7,1	8,9	10,8	15,5	20,2	25,0
	Max	54,5	79,6	128,4	176,3	223,7	270,8	388,2	505,9	624,5
DN 20	Min	3,8	5,6	9,0	12,3	15,7	19,0	27,2	35,4	43,7
	Max	95,4	139,2	224,6	308,5	391,4	473,9	679,3	885,3	1092,9
DN 25	Min	6,1	8,9	14,4	19,8	25,2	30,5	43,7	56,9	70,3
	Max	153,4	223,7	361,0	495,7	629,1	761,6	1091,8	1422,8	1756,5
DN 32	Min	10,2	14,9	24,1	33,0	41,9	50,8	72,8	94,9	117,1
	Max	255,6	372,9	601,7	826,2	1048,4	1269,3	1819,7	2371,4	2927,5
DN 40	Min	15,7	22,9	36,9	50,7	64,3	77,9	111,6	145,4	179,6
	Max	392,0	571,8	922,6	1266,9	1607,6	1946,3	2790,1	3636,1	4488,8
DN 50	Min	23,9	34,8	56,2	77,1	97,9	118,5	169,8	221,3	273,2
	Max	596,5	870,1	1404,0	1927,8	2446,3	2961,8	4245,9	5533,2	6830,7
DN 65	Min	49,1	71,6	115,5	158,6	201,3	243,7	349,4	455,3	562,1
	Max	1227,0	1789,9	2888,2	3965,8	5032,5	6092,8	8734,4	11382,6	14051,8
DN 80	Min	61,4	89,5	144,4	198,3	251,6	304,6	436,7	569,1	702,6
	Max	1533,8	2237,4	3610,3	4957,3	6290,6	7616,0	10918,0	14228,2	17564,7
DN 100	Min	95,4	139,2	224,6	308,5	391,4	473,9	679,3	885,3	1092,9
	Max	2385,8	3480,4	5616,0	7711,3	9785,3	11847,1	16983,5	22132,8	27322,9
DN 125	Min	150,0	218,8	353,0	484,7	615,1	744,7	1067,5	1391,2	1717,4
	Max	3749,2	5469,3	8825,2	12117,8	15375,9	18616,8	26688,4	34780,1	42935,9
DN 150	Min	204,5	298,3	481,4	661,0	838,7	1015,5	1455,7	1897,1	2342,0
	Max	5112,5	7458,1	12034,3	16524,2	20968,5	25386,6	36393,2	47427,4	58549,0
DN 200	Min	374,9	546,9	882,5	1211,8	1537,7	1861,7	2668,8	3478,0	4293,6
	Max	9373,0	13673,2	22062,9	30294,4	38442,3	46542,0	66720,9	86950,3	107339,9
DN 250	Min	599,9	875,1	1412,0	1938,8	2460,3	2978,7	4270,1	5564,8	6869,8
	Max	14996,8	21877,1	35300,6	48471,0	61507,7	74467,3	106753,4	139120,4	171743,8
DN 300	Min	852,1	1243,0	2005,7	2754,0	3494,8	4231,1	6065,5	7904,6	9758,2
	Max	21302,2	31075,4	50142,9	68850,9	87368,9	105777,4	151638,4	197614,2	243954,2

I TERMS OF USE

“

To ensure accurate and reliable measurements with vortex flow meters, the following conditions must be met:

1. The pipe must always be completely full. (only for liquids)
2. A straight pipe length of 10D at the inlet and 5D at the outlet must be maintained. (only applies to liquids; varies for gas and steam applications)
3. The mounting direction must be the same as the flow direction.
4. A damper must be used in vibrating environments.
5. Cables must be protected and the device must be grounded.
6. A condensate trap must be used in steam lines.
7. Avoid sudden peak pressure changes.
8. In steam applications, the pipe line must be insulated along with the device

”

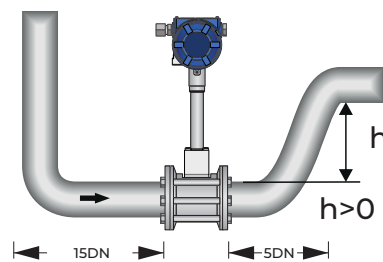

“

1. DN (Nominal Diameter): Unit of pipe diameter (e.g., DN100 = 100 mm pipe diameter).
2. Upstream direction: The straight pipe length before the flow meter.
3. Downstream direction: The straight pipe length after the flow meter.
4. Example: “25DN” means that a straight pipe length equal to 25 times the pipe diameter must be present before the flow meter.

”

Mounting Types

Minimum inlet direction pipe length	Minimum outlet direction pipe length
	<ol style="list-style-type: none"> Pipe expanders, pipe elbows, control valves, etc., in the flow outlet direction ≥ 5 DN Measurement points in the flow outlet direction ≥ 5 DN
<p>Control valve pipelines</p>	
<ol style="list-style-type: none"> Without disrupting flow, general inlet direction pipe length ≥ 15 DN After the control valve ≥ 50 DN After pipe diameter reduction ≥ 20 DN After a single 90° elbow ≥ 20 DN After a double $2 \times 90^\circ$ elbow ≥ 30 DN After two three-dimensional $2 \times 90^\circ$ elbows ≥ 40 DN Outlet direction > 5 DN 	

Mounting Types

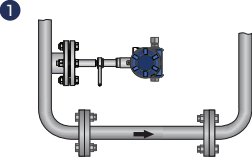
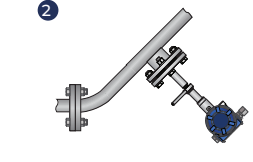
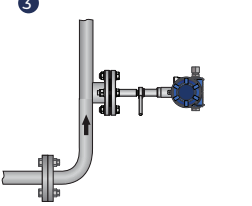
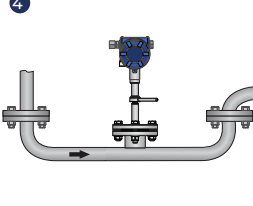
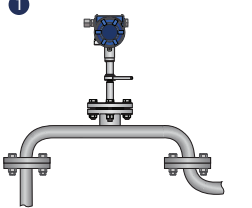
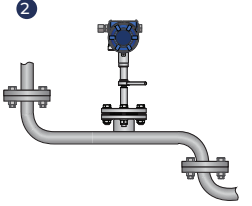
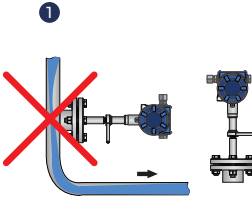
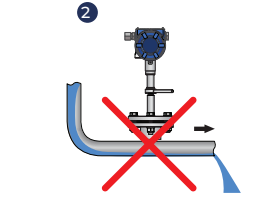
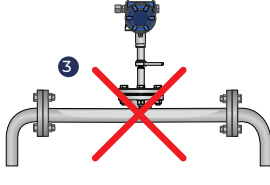
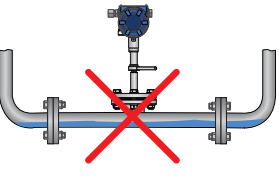
Liquid line applications	Gas and steam line applications
<div style="display: flex; justify-content: space-around;"> <div style="text-align: center;">  <p>1</p> </div> <div style="text-align: center;">  <p>2</p> </div> </div> <div style="display: flex; justify-content: space-around; margin-top: 20px;"> <div style="text-align: center;">  <p>3</p> </div> <div style="text-align: center;">  <p>4</p> </div> </div> <ol style="list-style-type: none"> 1. If the device is installed in a pipe with downward flow, a balancing pipe must be installed immediately behind it. 2. Installing the device in an inclined vertical pipe 3. Installing the device in a vertical pipe 4. Installing the device in a low pipe elbow 	<div style="text-align: center; margin-bottom: 20px;">  <p>1</p> </div> <div style="text-align: center;">  <p>2</p> </div> <ol style="list-style-type: none"> 1. Attaching the device to the pipe where the flow is downward 2. Attaching the device in front of an outlet 3. Attaching the device to the upper pipe elbow due to the risk of gas bubbles forming
<div style="display: flex; justify-content: space-around; margin-bottom: 20px;"> <div style="text-align: center;">  <p>1</p> </div> <div style="text-align: center;">  <p>2</p> </div> </div> <div style="text-align: center; margin-bottom: 20px;">  <p>3</p> </div> <ol style="list-style-type: none"> 1. Attaching the device to the pipe where the flow is downward 2. Attaching the device in front of an outlet 3. Attaching the device to the upper pipe elbow due to the risk of gas bubbles forming 	<div style="text-align: center; margin-bottom: 20px;">  <p>1</p> </div> <ol style="list-style-type: none"> 1. Low pipe elbows 2. Condensate <p>Attaching the device to the lower pipe elbow carries a risk of condensation forming. Gas bubbles can cause pressure fluctuations and incorrect measurement. In certain circumstances, the device may be damaged and the measured fluid may leak.</p>

VTRANS (V) - **F** - **100** - **PT** - **G** - **H** - **HT** - **Pn10**
 ① ② ③ ④ ⑤ ⑥ ⑦

① Product Type / Connection

Wafer-Type Vortex Flowmeter (sandwich)	<input type="checkbox"/>	W
Flange-Type Vortex Flow Meter	<input checked="" type="checkbox"/>	F
Separate Type Vortex Flowmeter	<input type="checkbox"/>	R
Immersion Type Vortex Flowmeter	<input type="checkbox"/>	D

② DN -Ø

Pipe Diameter - DN	<input type="checkbox"/>	XXX
--------------------	--------------------------	------------

③ Model

Temperature Pressure Comp.	<input checked="" type="checkbox"/>	PT
No display / No computer	<input type="checkbox"/>	D

④ Fluid

Liquid	<input type="checkbox"/>	S
Gas	<input checked="" type="checkbox"/>	G
Saturated Steam	<input type="checkbox"/>	BB
Superheated Steam	<input type="checkbox"/>	KB

⑤ OPS Output

None	<input checked="" type="checkbox"/>	X
Hart Output	<input type="checkbox"/>	H
Modbus Output	<input type="checkbox"/>	RS485

⑥ OPS Temperature

None	<input checked="" type="checkbox"/>	X
High Temperature 350°C	<input type="checkbox"/>	HT
Standard	<input type="checkbox"/>	X

⑦ Pressure

10Bar	<input checked="" type="checkbox"/>	Pn10
16Bar	<input type="checkbox"/>	Pn16
25Bar	<input type="checkbox"/>	Pn25
40Bar	<input type="checkbox"/>	Pn40
63Bar	<input type="checkbox"/>	Pn63

Contact us

Adress :

Reinmeer Factory Address
Eutiner Str.12,22143
Hamburg, Germany
reinmeer@reinmeer.com